

FLIPPER

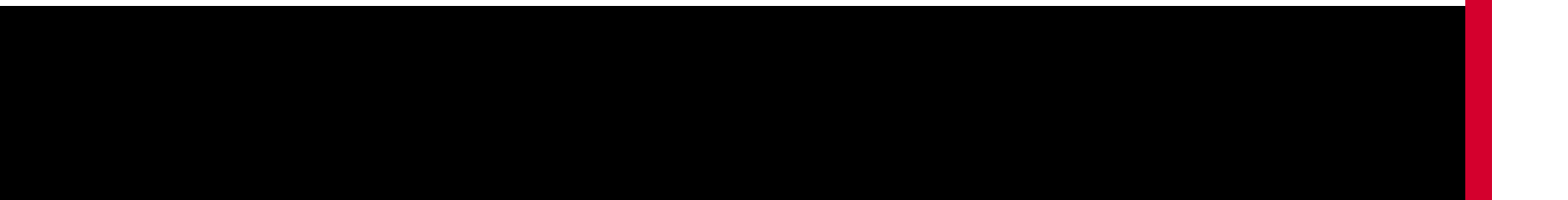



FLIPPER is the wood shelf support slotted into the shelf by making face borings.

The shelf has to be pushed downwards onto the side dowels, which can be placed or screwed into any position required.

The side dowels slot into the socket of the shelf supports and a click locks the shelf in position.

To provide a structural fastening to the furniture screwed side dowels are required, so that the shelf flushes with the sides, due to the angled shape of the shelf support sockets.

In accordance with the regulation: UNI EN 14749/05.



ASSEMBLING

1

INSERT THE FLIPPER SUPPORT INTO THE SHELF

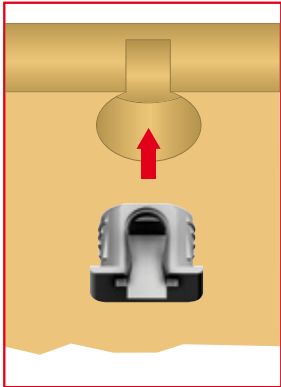

ASSEMBLING WITH SMOOTH PIN

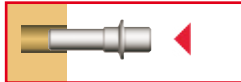

ASSEMBLING WITH THREADED PIN TO ACHIEVE HORIZONTAL CONNECTION

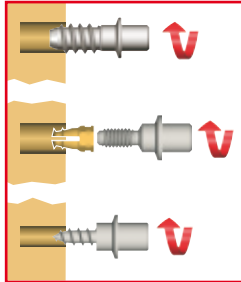

2

INSERT THE SHELF DIAGONALLY INTO THE CABINET (ALSO WITH DOOR ALREADY ASSEMBLED)

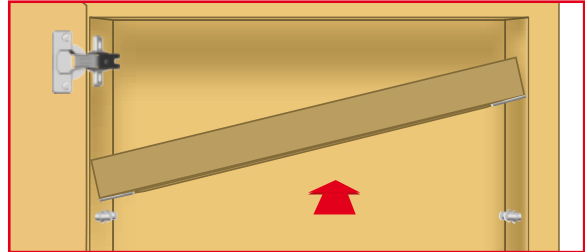

3

PLACE THE SHELF OVER THE PINS

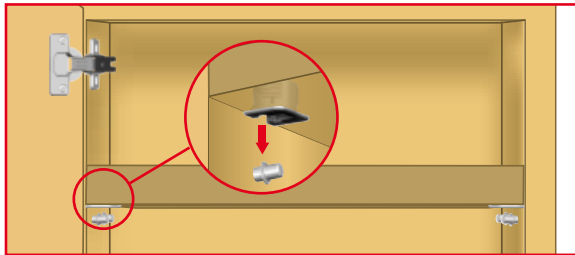

4

PRESS THE SHELF DOWN

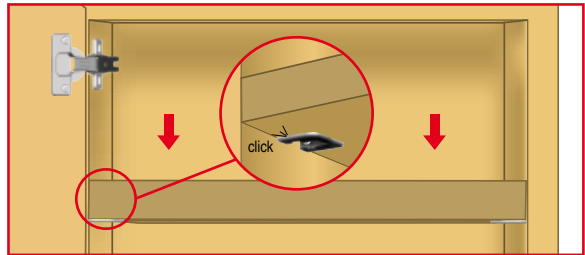

SHELF REMOVAL AND REPOSITIONING

SHELF REMOVAL
PUSH THE SHELF UPWARDS FOR RELEASE

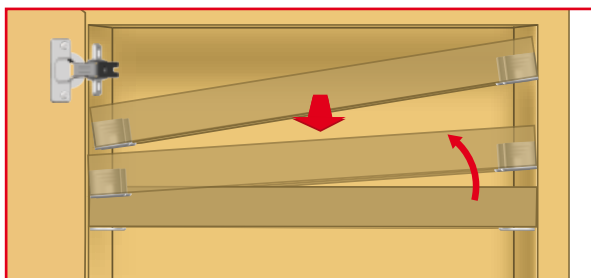

SHELF REPOSITIONING
TO REPOSITION THE SHELF REPEAT OPERATIONS AS SHOWN IN PCS.2-3-4.

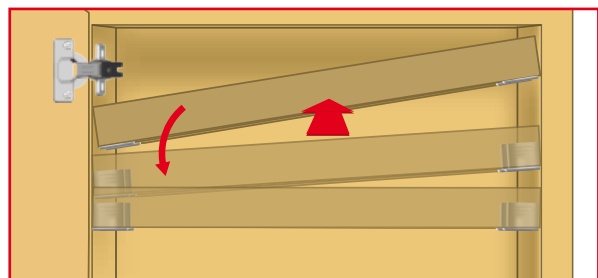

SUPPORT FOR FLIPPER - MINIMUM 12mm THICK WOOD SHELVES

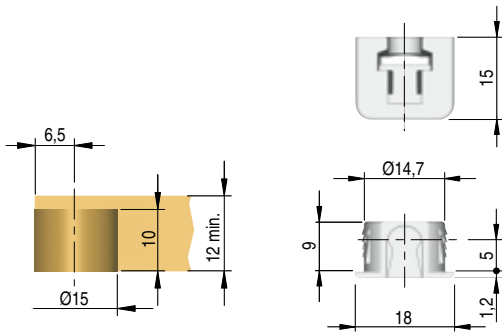

Face boring snap fix for 12mm shelf.
Engineering plastic

Part. no	Finish
10601010AB	White
10601010JG	Aluminium 5

Other finishes available on request

SUPPORT FOR FLIPPER - MINIMUM 14mm THICK WOOD SHELVES

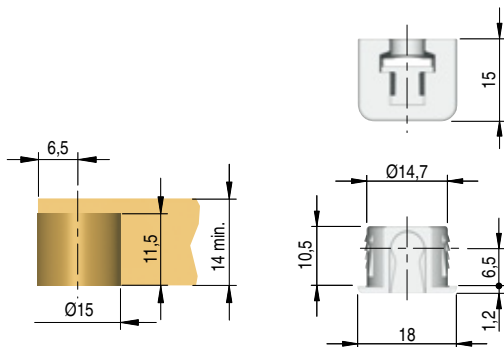

Face boring snap fix for 14mm shelf.
Engineering plastic

Part. no	Finish
10601020AB	White
10601020JG	Aluminium 5

Other finishes available on request

SUPPORT FOR FLIPPER - MINIMUM 18mm THICK WOOD SHELVES

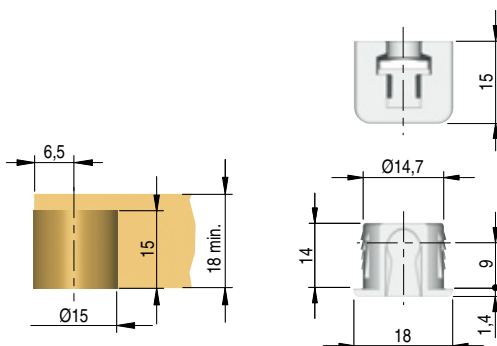

Face boring snap fix for 18mm shelf.
Engineering plastic

Part. no	Finish
10601030AB	White
10601030JG	Aluminium 5

Other finishes available on request

DOWEL FOR FLIPPER

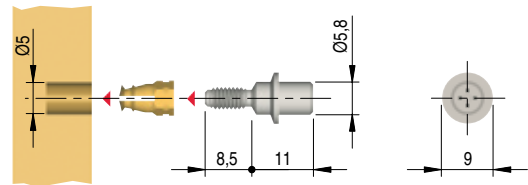

For M4 spreading dowel
Steel

Part. no	Finish
10602010ZN	Zinc-plated

DOWEL FOR FLIPPER

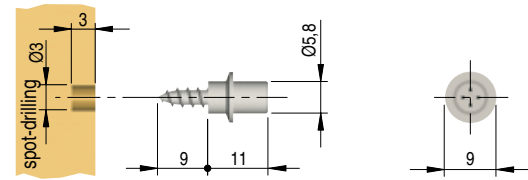

Ø 3mm screw
Steel

Part. no	Finish
10603010ZN	Zinc-plated

DOWEL FOR FLIPPER

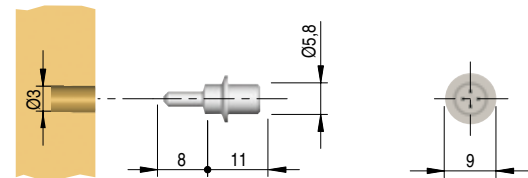

With smooth pin Ø 3
Steel

Part. no	Finish
10605030ZN	Zinc-plated

DOWEL FOR FLIPPER

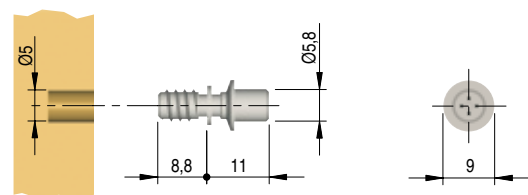

Ø 5mm euro screw
Steel

Part. no	Finish
10604010ZN	Zinc-plated

DOWEL FOR FLIPPER

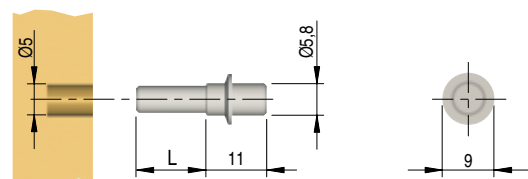

With smooth
pin Ø 5mm
Steel

L	Part. no	Finish
12,5	10605020ZN	Zinc-plated
8,5	10605010ZN	Zinc-plated

DOWEL FOR FLIPPER

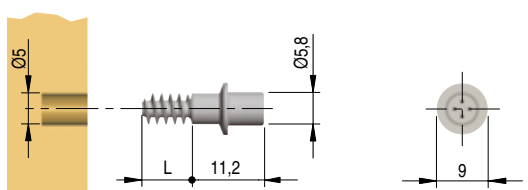

Removable
threaded bolt
Steel

L	Part. no	Finish
9,7	10606020ZN	Zinc-plated
7,7	10606010ZN	Zinc-plated



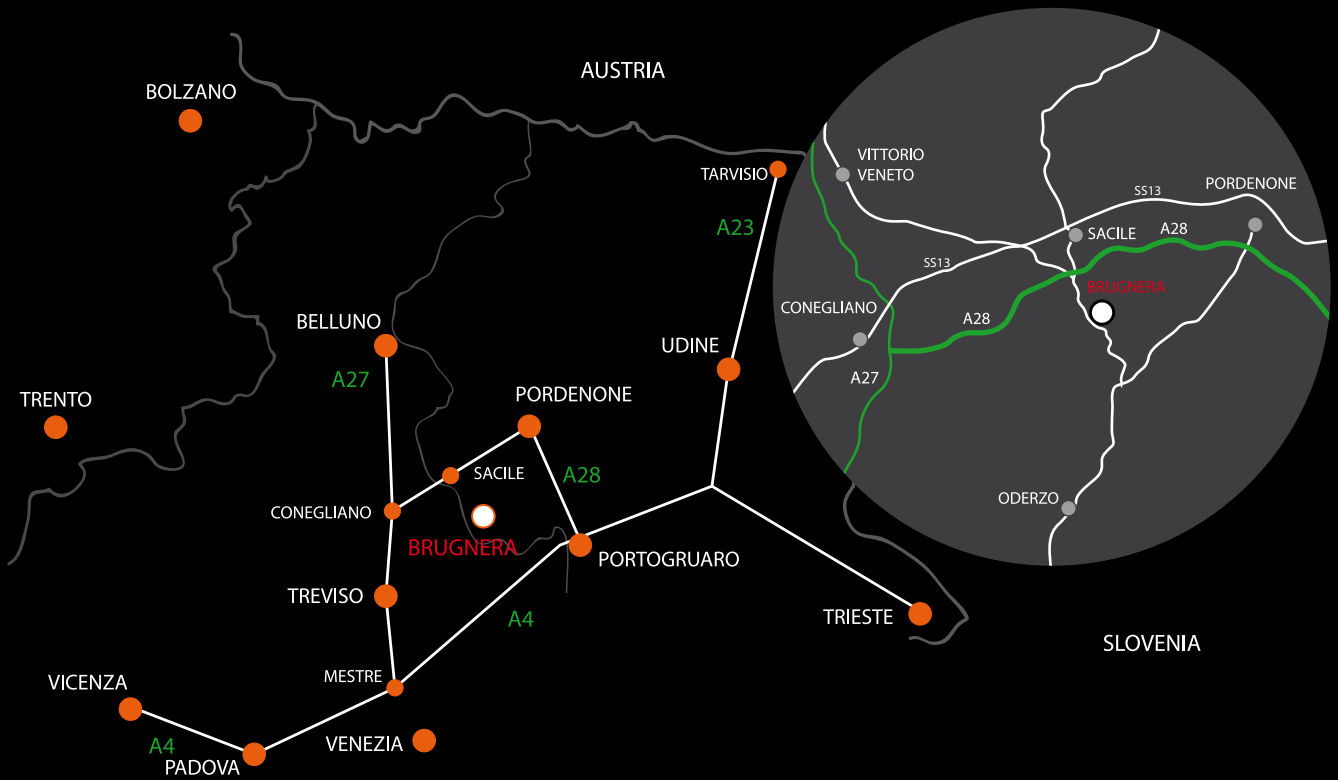

ITALIANA FERRAMENTA

Via Taglio n° 87 I - 33070 Maron di Brugnera (PN) Tel. +39 0434 428211 Fax +39 0434 428242 www.italianaferramenta.com info@italianaferramenta.it