

CODE
1005

profilo gola a "C"
"C" gola profile



CARATTERISTICHE TECNICHE SPECIFICATIONS

codice code						
	H (mm)	L (mm)	pcs	m	kg	PxLxH (cm)
701005xxx00410	56	4.100	16	65,6	24	22x502x17

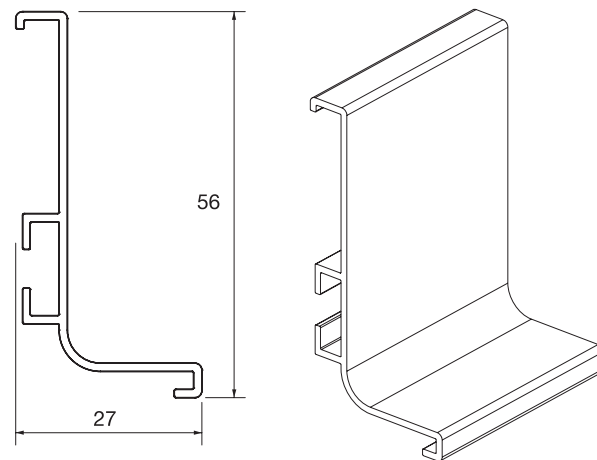

FINITURE/COLORE FINISH/COLOURS

Per completare il codice della versione scelta sostituire "xxx" con il codice della finitura. Per le finiture disponibili vedi pag. 82.
To complete the code of the version chosen, replace "xxx" with the code of the finish. See page 82 for available finishes.

NOTE PER LA FRESATURA DEL MOBILE ADVICES FOR CABINET MILLING

Per la fresatura del mobile vedi pag. 79 For the cabinet milling see pag. 79

ACCESSORI ACCESSORIES

CODE 1015E
angolo esterno 90°, alluminio
external joint 90°, aluminium



CODE 1015I
angolo interno 90°, alluminio
internal joint 90°, aluminium



CODE 1013
tappo aperto destro + tappo aperto
sinistro, alluminio / open right end
cap + open left end cap, aluminium

CODE 1043
tappo aperto destro + tappo aperto
sinistro, plastica / open right end cap
+ open left end cap, plastic



CODE 995
tappo chiuso destro + tappo chiuso
sinistro, alluminio / closed right end
cap + closed left end cap, aluminium

CODE 1044
tappo chiuso destro + tappo chiuso
sinistro, plastica / closed right end
cap + closed left end cap, plastic

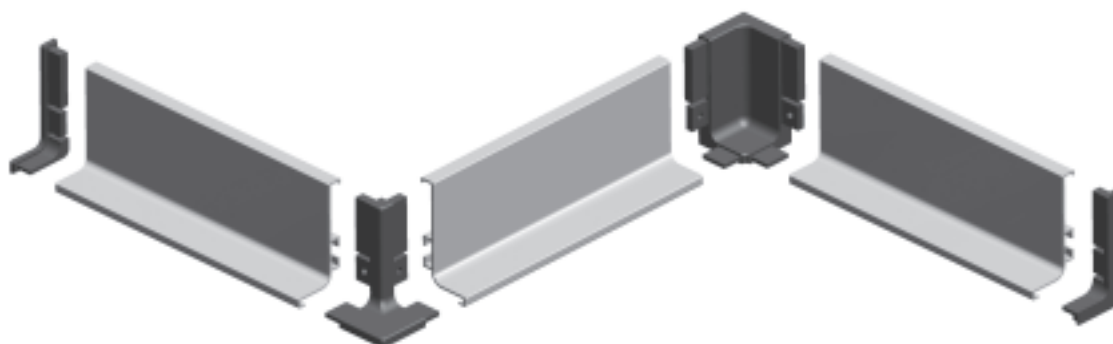

Soluzioni di montaggio Assembly solutions

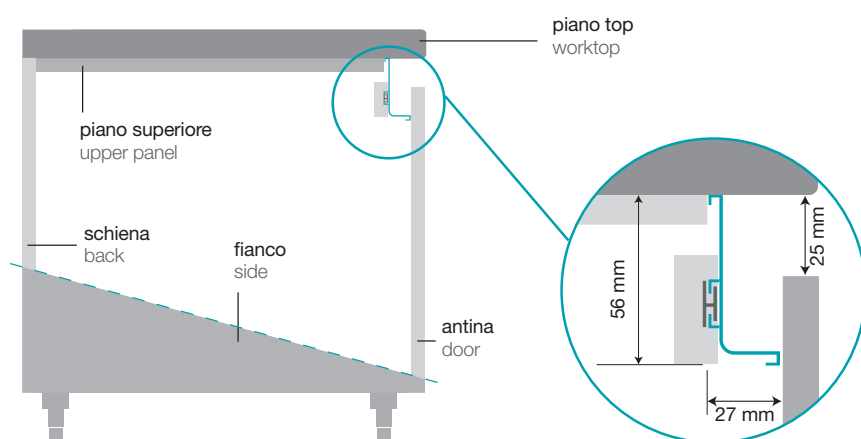

CODE 1010



L'altezza delle antine va ridotta di 25 mm.
La profondità del piano superiore va ridotta di 27 mm.

The door height to be decreased by 25 mm.
The upper panel depth to be decreased by 27 mm.

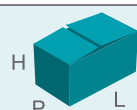
codice code			
	pcs	kg	PxLxH (cm)
701015E0xxx001	20	1	24x24x13
701015I0xxx001	20	1	24x24x13
70101300xxx001	10+10	0,5	24x24x13
70995000xxx001	10+10	2	24x24x13

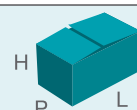
codice code			
	pcs	kg	PxLxH (cm)
70104300xxx100	100+100	1,5	24x24x13
70104400xxx100	100+100	1	24x24x13
70101000000200	200+200	4	24x24x13

CODE
1004

profilo gola a "C"
"C" gola profile



CARATTERISTICHE TECNICHE SPECIFICATIONS

codice code						
	H (mm)	L (mm)	pcs	m	kg	PxLxH (cm)
701004xxx00410	72,7	4.100	16	65,6	30	22x502x17

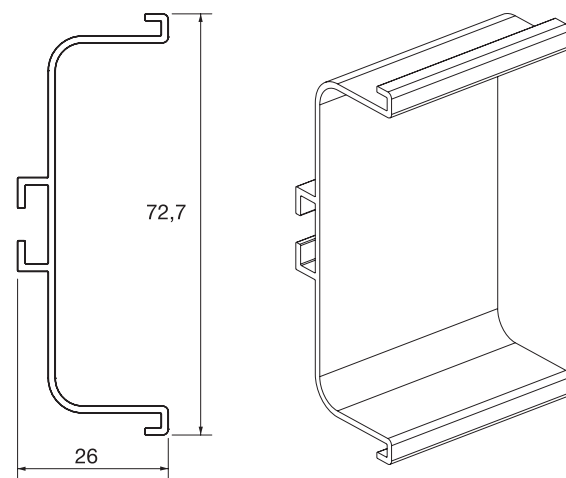

FINITURE/COLORE FINISH/COLOURS

Per completare il codice della versione scelta sostituire "xxx" con il codice della finitura. Per le finiture disponibili vedi pag. 82.
To complete the code of the version chosen, replace "xxx" with the code of the finish. See page 82 for available finishes.

NOTE PER LA FRESATURA DEL MOBILE ADVICES FOR CABINET MILLING

Per la fresatura del mobile vedi pag. 79 For the cabinet milling see pag. 79

ACCESSORI ACCESSORIES

CODE tappo aperto ambidestro, alluminio
1014 open right / left end cap, aluminium

CODE tappo aperto ambidestro, plastica
1045 open right / left end cap, plastic

CODE tappo chiuso ambidestro, alluminio
996 closed right / left end cap, aluminium

CODE tappo chiuso ambidestro, plastica
1046 closed right / left end cap, plastic

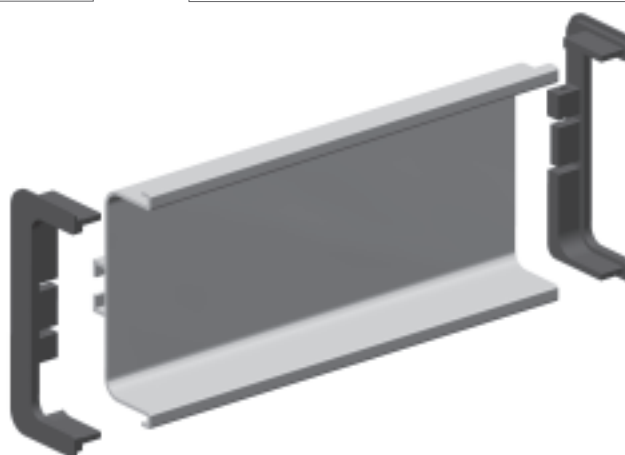

Soluzioni di montaggio Assembly solutions

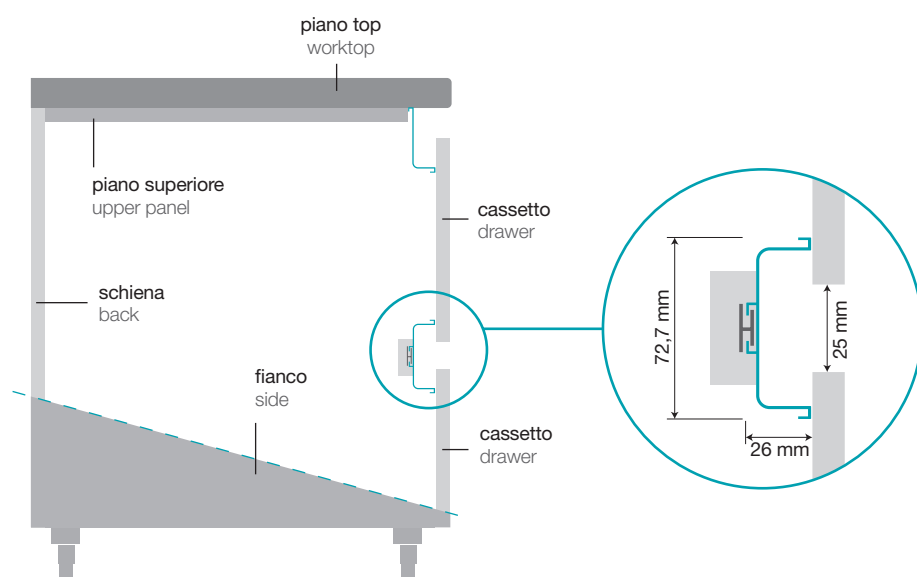

CODE 1010



L'altezza del frontale del cassetto va ridotta di 25 mm.
The drawer front panel height to be decreased by 25 mm.

codice code			
	pcs	kg	PxLxH (cm)
70101400xxx001	20	0,5	24x24x13
70104500xxx001	100	1	24x24x13
70996000xxx001	20	0,5	24x24x13

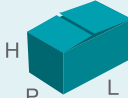
codice code			
	pcs	kg	PxLxH (cm)
70104600xxx001	100	1	24x24x13
70101000000200	200 + 200	4	24x24x13

CODE
1019

gola verticale intermedia aperta
recessed vertical double grip profile

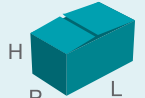

CARATTERISTICHE TECNICHE SPECIFICATIONS

codice code						
	H (mm)	L (mm)	pcs	m	kg	PxLxH (cm)
701019xxx00440	66,5	4.400	12	52,8	35	22x502x17

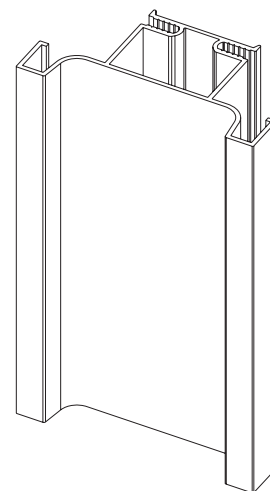
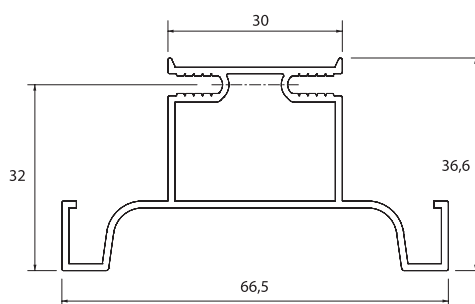



Soluzioni di montaggio Assembly solutions

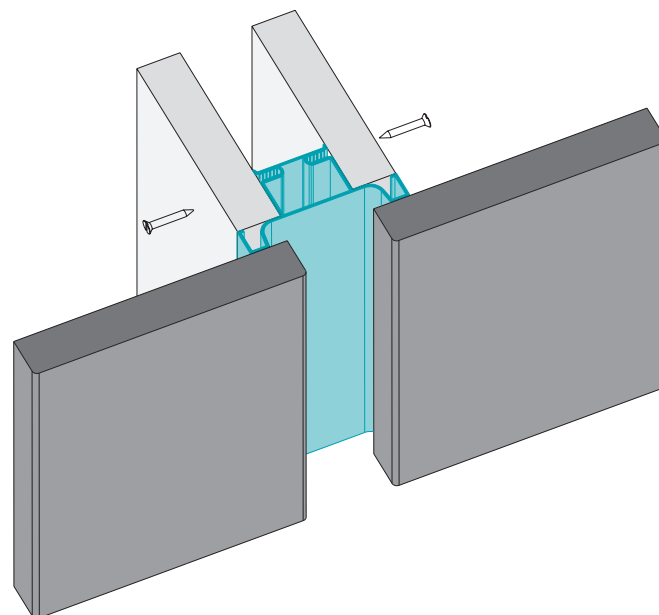
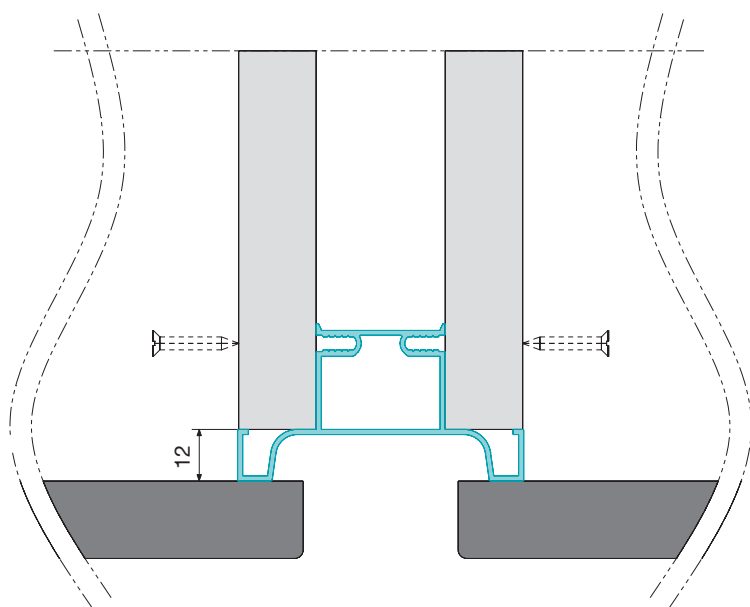

FINITURE/COLORE FINISH/COLOURS



Per completare il codice della versione scelta sostituire "xxx" con il codice della finitura. Per le finiture disponibili vedi pag. 82.
To complete the code of the version chosen, replace "xxx" with the code of the finish. See page 82 for available finishes.

CODE
1020

gola verticale terminale aperta
recessed vertical single grip profile



CARATTERISTICHE TECNICHE SPECIFICATIONS

codice code						
	H (mm)	L (mm)	pcs	m	kg	PxLxH (cm)
701020xxx00440	48,25	4.400	15	66	38	22x502x17

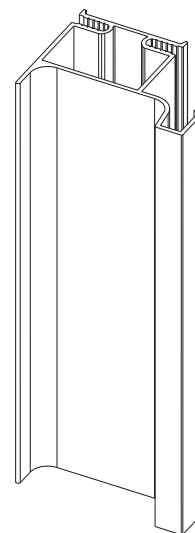
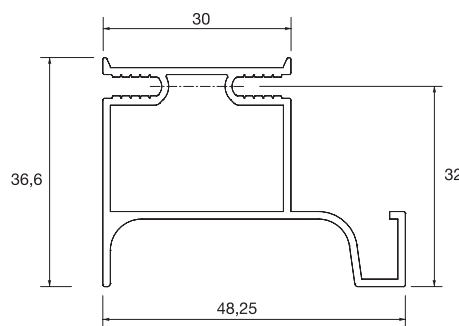



Soluzioni di montaggio Assembly solutions

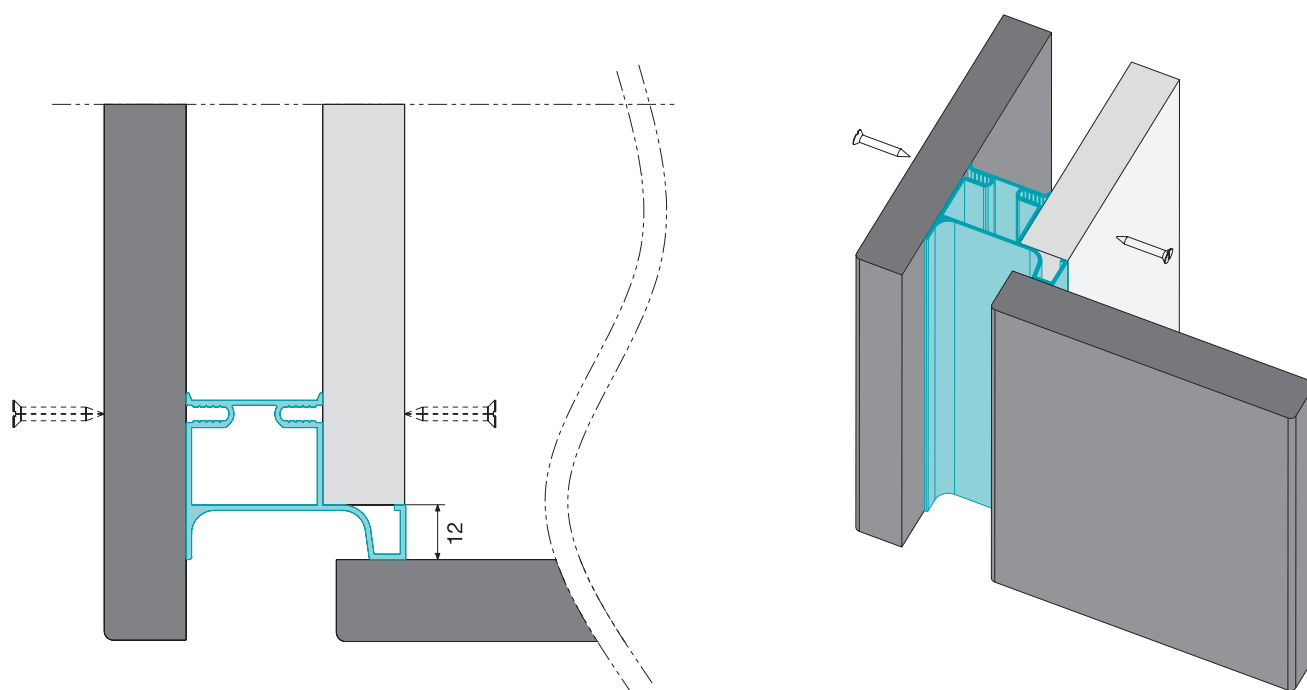

FINITURE/COLORE FINISH/COLOURS

Per completare il codice della versione scelta sostituire "xxx" con il codice della finitura. Per le finiture disponibili vedi pag. 82.
To complete the code of the version chosen, replace "xxx" with the code of the finish. See page 82 for available finishes.

CODE
966

gola base chiusa
closed horizontal gola profile

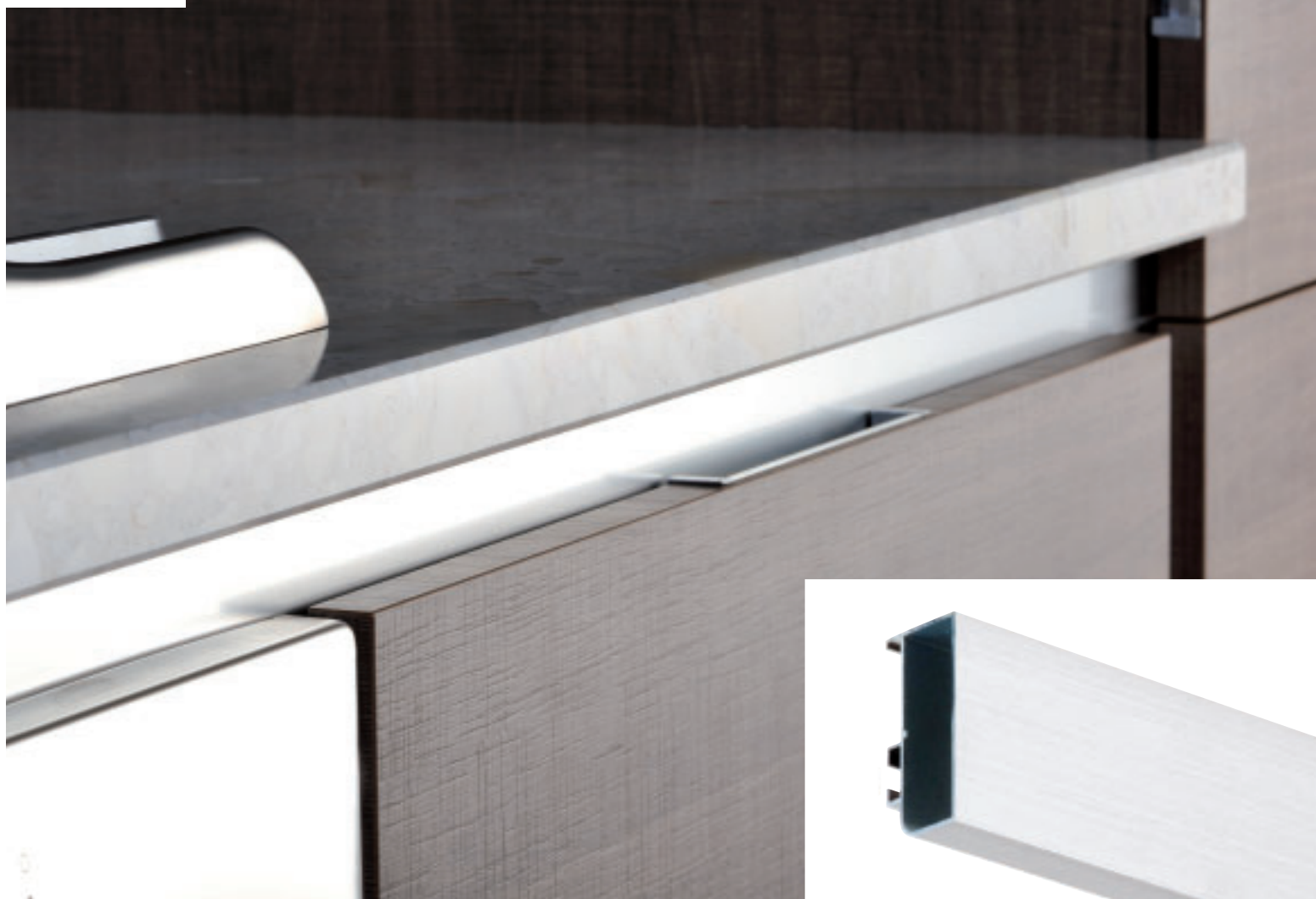

CARATTERISTICHE TECNICHE SPECIFICATIONS

codice code						
	H (mm)	L (mm)	pcs	m	kg	PxLxH (cm)
70966xxx000390	56	3.900	20	78	45	22x402x17

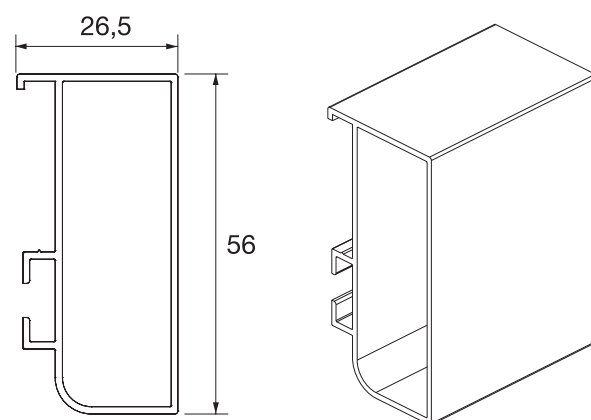

FINITURE/COLORE FINISH/COLOURS

Per completare il codice della versione scelta sostituire "xxx" con il codice della finitura. Per le finiture disponibili vedi pag. 82.
To complete the code of the version chosen, replace "xxx" with the code of the finish. See page 82 for available finishes.

NOTE PER LA FRESATURA DEL MOBILE ADVICES FOR CABINET MILLING

Per la fresatura del mobile vedi pag. 79 For the cabinet milling see pag. 79

ACCESSORI ACCESSORIES

CODE 997E angolo esterno 90°, alluminio
external joint 90°, aluminium



CODE 997I angolo interno 90°, alluminio
internal joint 90°, aluminium

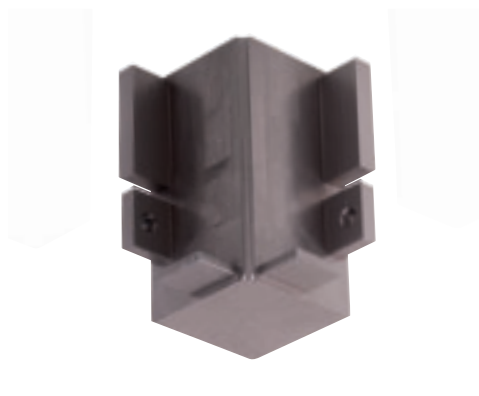

CODE 995 tappo chiuso destro + sinistro, alluminio
closed right end cap + closed left end cap, aluminium

CODE 1044 tappo chiuso destro + sinistro, plastica
closed right end cap + closed left end cap, plastic



Soluzioni di montaggio Assembly solutions

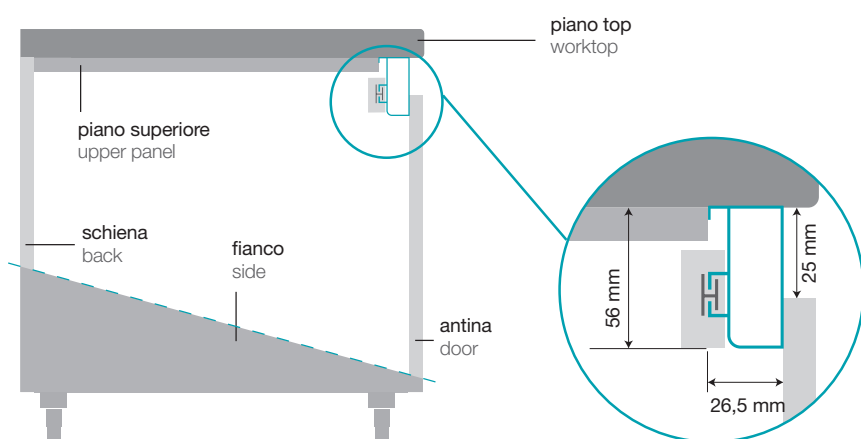

CODE 1010



L'altezza delle antine va ridotta di 25 mm.
La profondità del piano superiore va ridotta di 27 mm.

The door height to be decreased by 25 mm.
The upper panel depth to be decreased by 27 mm.



codice code			
	pcs	kg	PxLxH (cm)
70997E00xxx001	20	1	24x24x13
70997I00xxx001	20	1	24x24x13
70995000xxx001	10 + 10	0,5	24x24x13
70104400xxx100	100 + 100	1,5	24x24x13
70101000000200	200 + 200	4	24x24x13

CODE
967

gola cassetto chiusa
closed gola profile for drawer



CARATTERISTICHE TECNICHE SPECIFICATIONS

codice code						
	H (mm)	L (mm)	pcs	m	kg	PxLxH (cm)
70967xxx000390	72,7	3.900	16	62,4	50	22x402x17

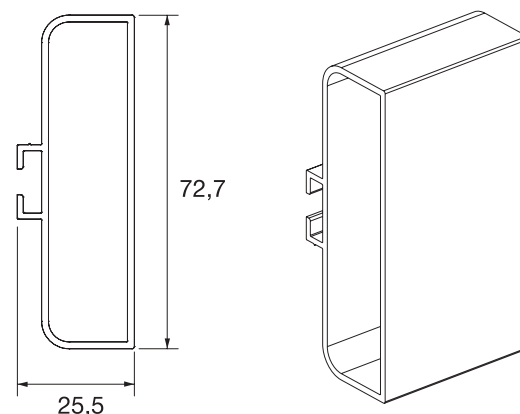

FINITURE/COLORE FINISH/COLOURS

Per completare il codice della versione scelta sostituire "xxx" con il codice della finitura. Per le finiture disponibili vedi pag. 82.
To complete the code of the version chosen, replace "xxx" with the code of the finish. See page 82 for available finishes.

NOTE PER LA FRESATURA DEL MOBILE ADVICES FOR CABINET MILLING

Per la fresatura del mobile vedi pag. 79 For the cabinet milling see pag. 79

ACCESSORI ACCESSORIES

CODE tappo chiuso ambidestro, alluminio
996 closed right / left end cap, aluminium

CODE tappo chiuso ambidestro, plastica
1046 closed right / left end cap, plastic

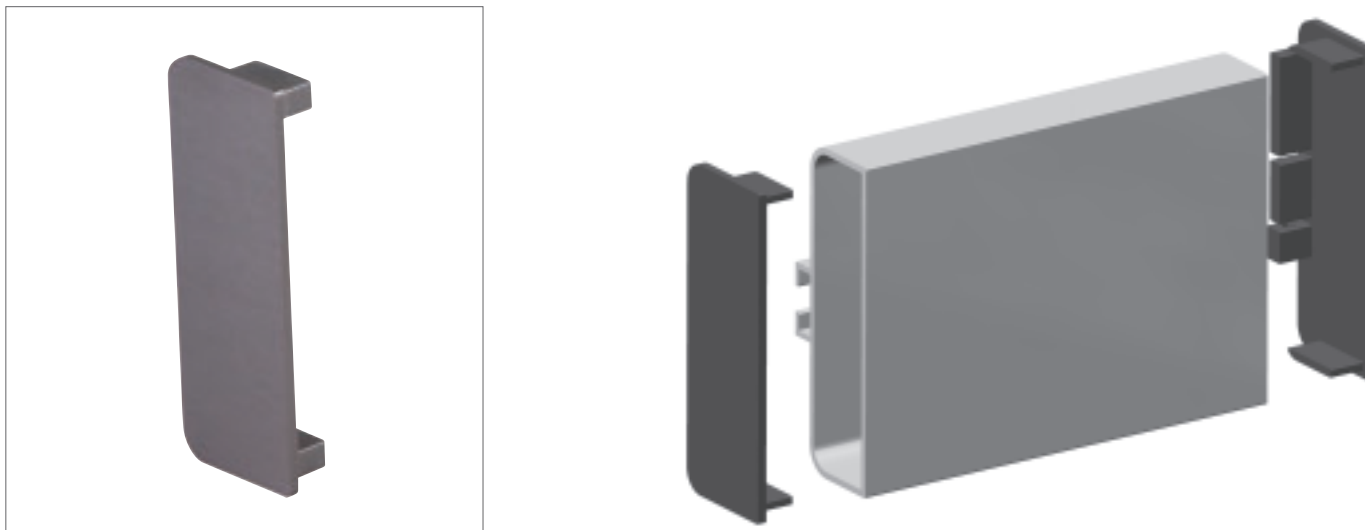

Soluzioni di montaggio Assembly solutions

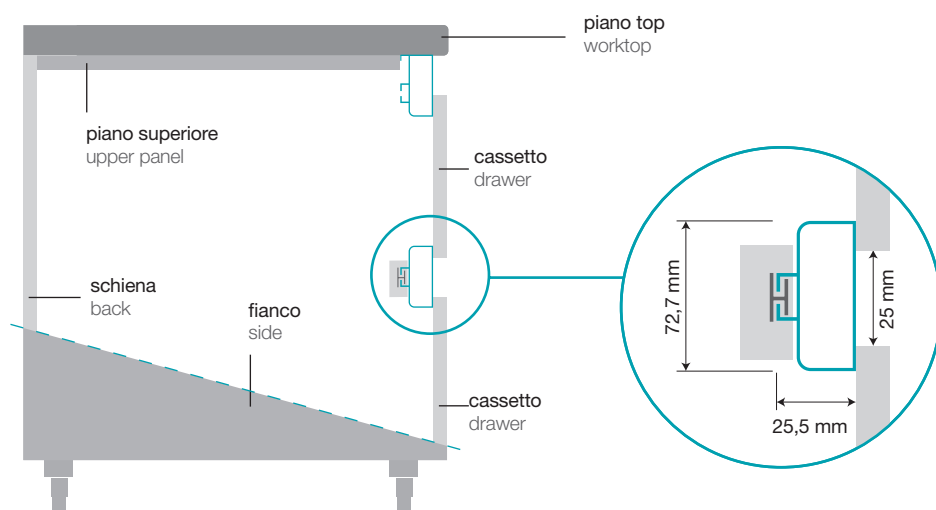

CODE 1010



L'altezza del frontale del cassetto va ridotta di 25 mm.
The drawer front panel height to be decreased by 25 mm.

codice code			
	pcs	kg	PxLxH (cm)
70996000xxx001	20	0,5	24x24x13
70101000000200	200+200	4	24x24x13

Fresatura mobile 266-267 Milling of the cabinet 266-267

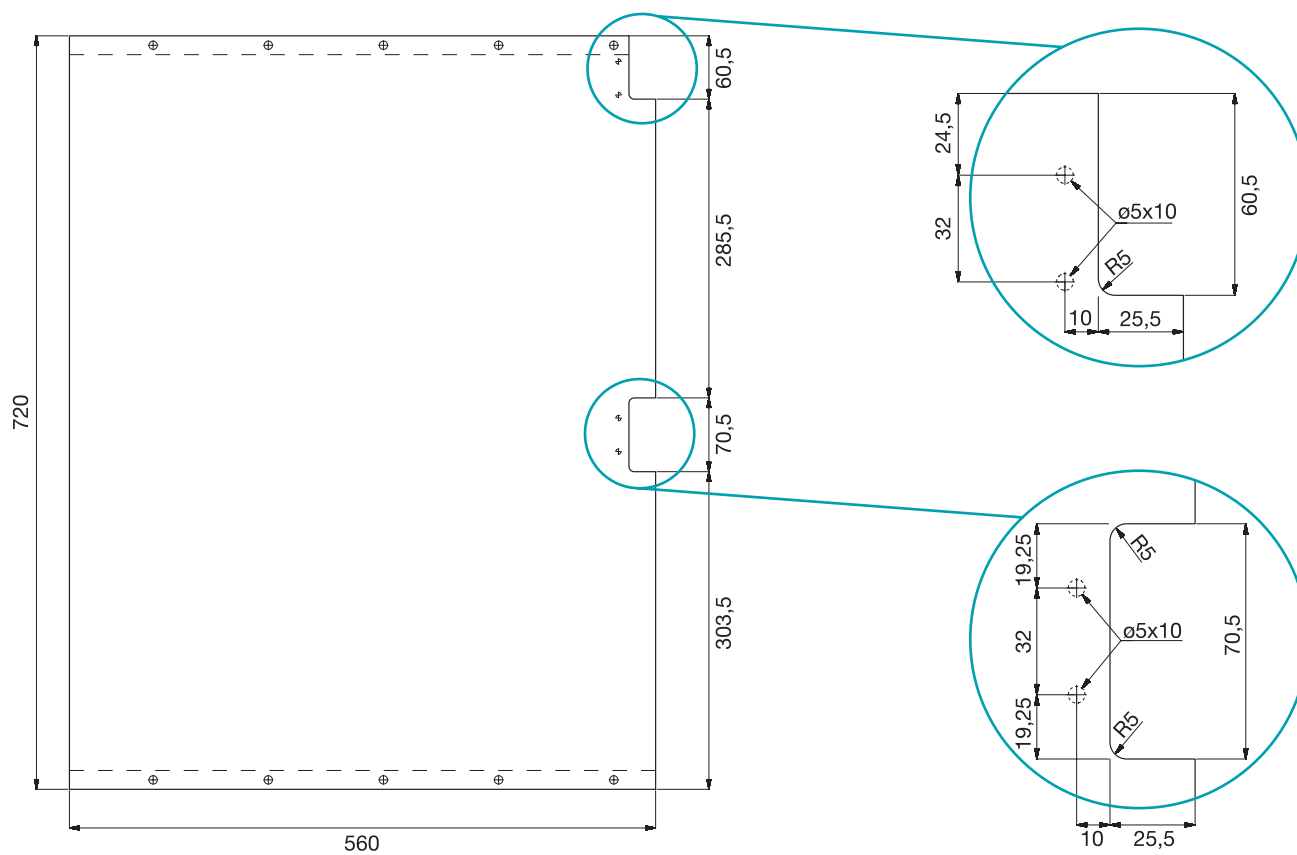

Fresatura mobile 966-967-1004-1005 Milling of the cabinet 966-967-1004-1005

