

# SLIDE

## ISTRUZIONI DI MONTAGGIO ASSEMBLY INSTRUCTIONS

MODELLI  
MODELS:

411/78.1241.22 SLIDE 120x120 cm  
411/78.1242.22 SLIDE DX / R 120x95 cm  
411/78.1243.22 SLIDE SX / L 120x95 cm

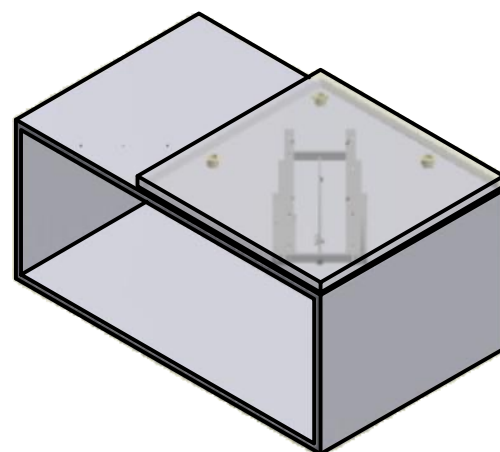

## CONTENUTO DELLA CONFEZIONE INCLUDED IN THE PACKAGING

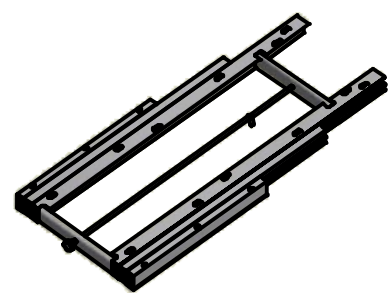

GUIDE/SLIDES  
411/78.1241.22

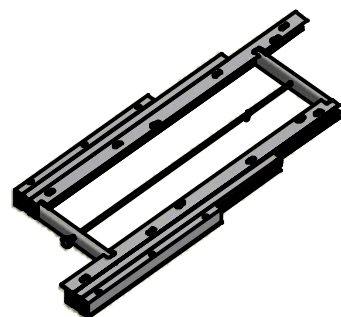

GUIDE/SLIDES  
411/78.1242.22



GUIDE/SLIDES  
411/78.1243.22

### SACCHETTO ACCESSORI - ACCESSORIES

- A. Chiave esa. da 4 - n° 4 Allen key (x 1)
- B. Bussola M6 - M6 bush (x 8)
- C. Ruota - Wheel (x 3)
- D. Rondella - Washer (x 6)
- E. Perno - Pin (x 4)
- F. Blocco - Block (x 1)
- G. Dado M6 - Nut M6 (x 6)
- H. Vite truciolare 4.5x30 - 4.5x30 FHP screw (x 3)
- I. Vite TPS M6x60 - M6x60 FHCS screw (x 4)
- J. Vite TPS M6x90/100/120 - M6x90/100/120 FHCS screw (x 6)

## SEQUENZA DI FUNZIONAMENTO FUNCTIONING STEPS

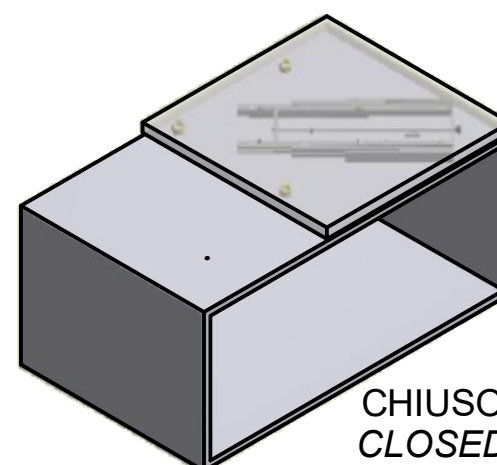

CHIUSO  
CLOSED

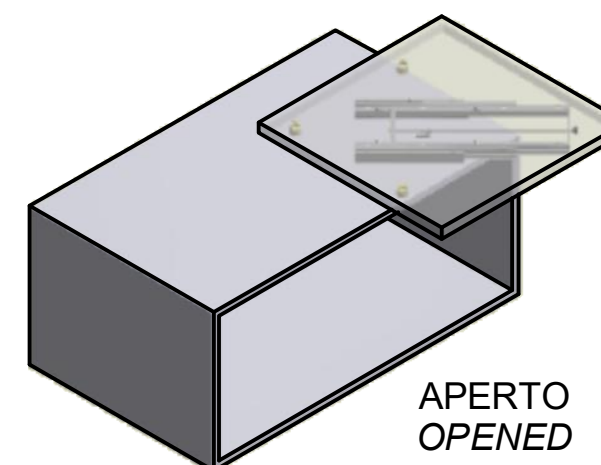

APERTO  
OPENED

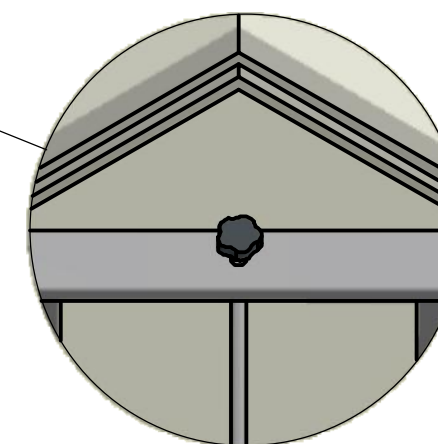
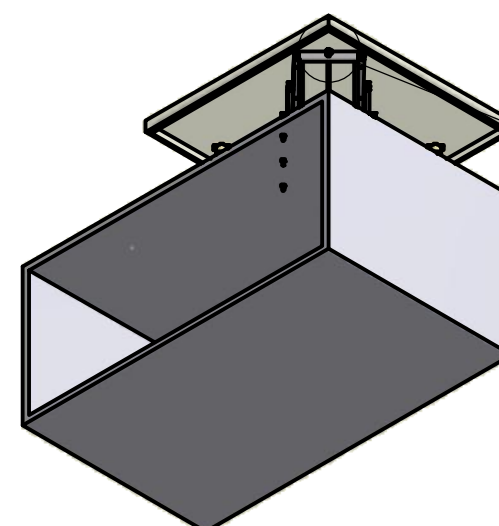

BLOCCO PIANO  
RUOTARE POMELLO  
TOP LOCK  
TURN THE KNOB

## DIMENSIONI SUPPORTO RUOTA (x 3) SIZES SUPPORT WHEEL (x 3)

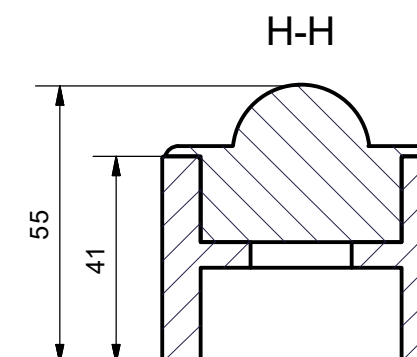
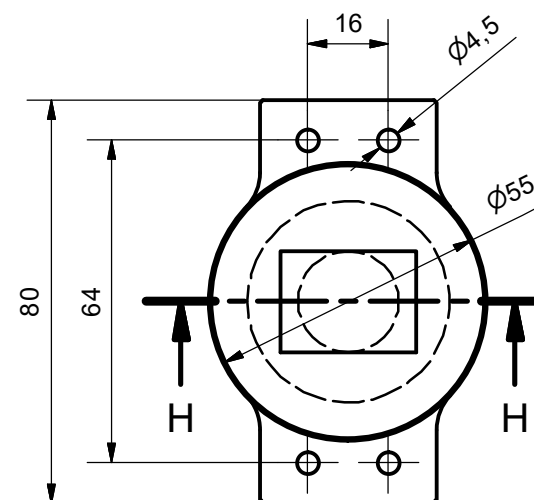

# DIMENSIONI GENERALI

## GENERAL SIZES

411/78.1241.22  
VISTA DALL'ALTO / TOP VIEW

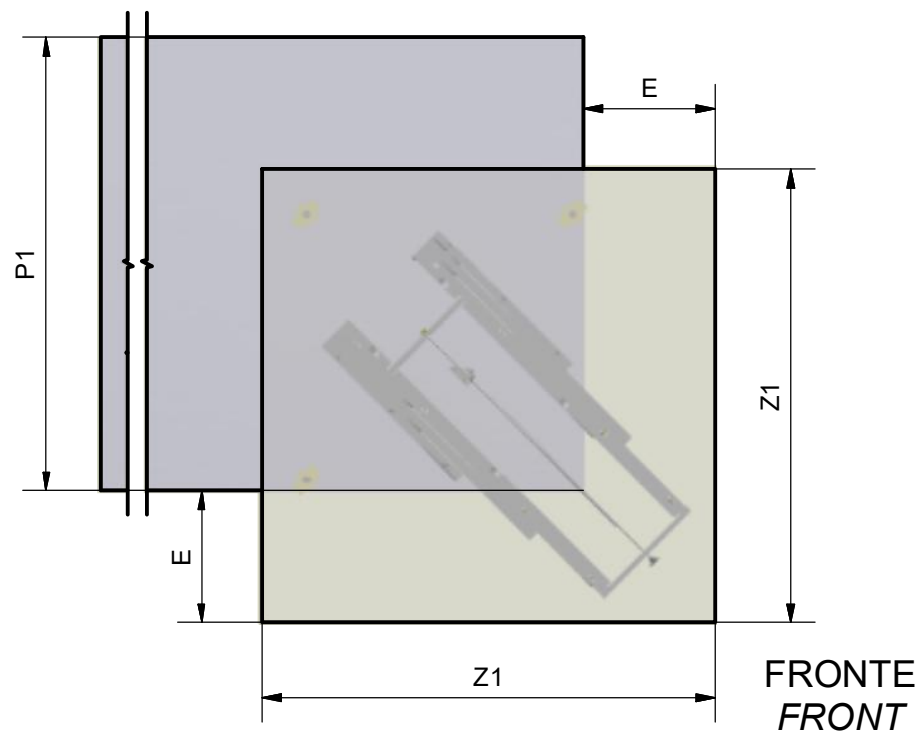

411/78.1242.22  
VISTA DALL'ALTO / TOP VIEW

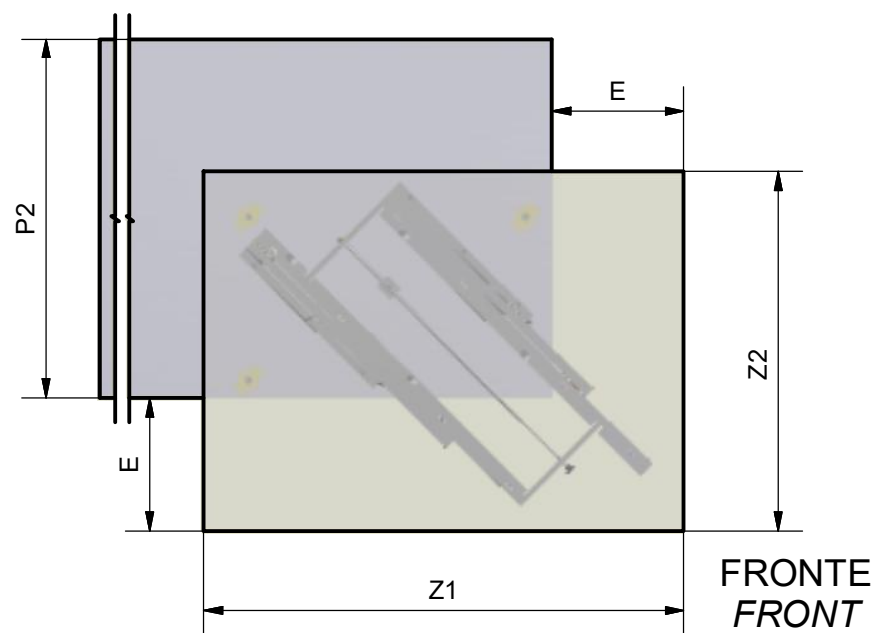

411/78.1243.22  
VISTA DALL'ALTO / TOP VIEW

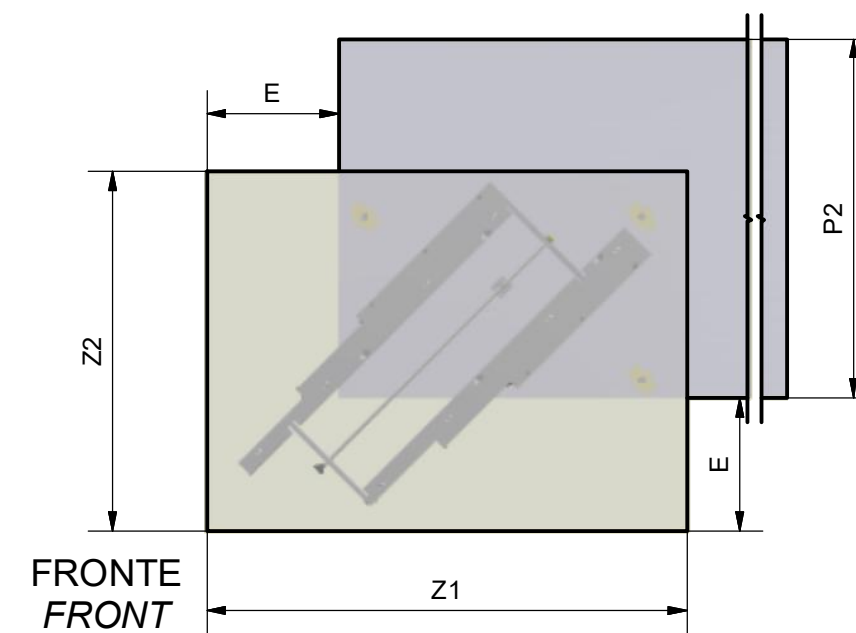

411/78.1241.22	SIMBOLO - SYMBOL	mm
ALTEZZA - HEIGHT	H	56
LARGHEZZA - WIDTH	P1	1200
DIMENSIONE PIANO - TOP DIMENSION	Z1	1200
SPESSORE PIANO - TOP THICKNESS	S	MIN: 18
APERTURA MAX - MAX OPENING	E	350

411/78.1252.22 - 411/78.1243.22	SIMBOLO - SYMBOL	mm
ALTEZZA - HEIGHT	H	56
LARGHEZZA - WIDTH	P2	950
DIMENSIONE PIANO - TOP DIMENSION	Z1	1270
DIMENSIONE PIANO - TOP DIMENSION	Z2	950
SPESSORE PIANO - TOP THICKNESS	S	MIN: 18
APERTURA MAX - MAX OPENING	E	350

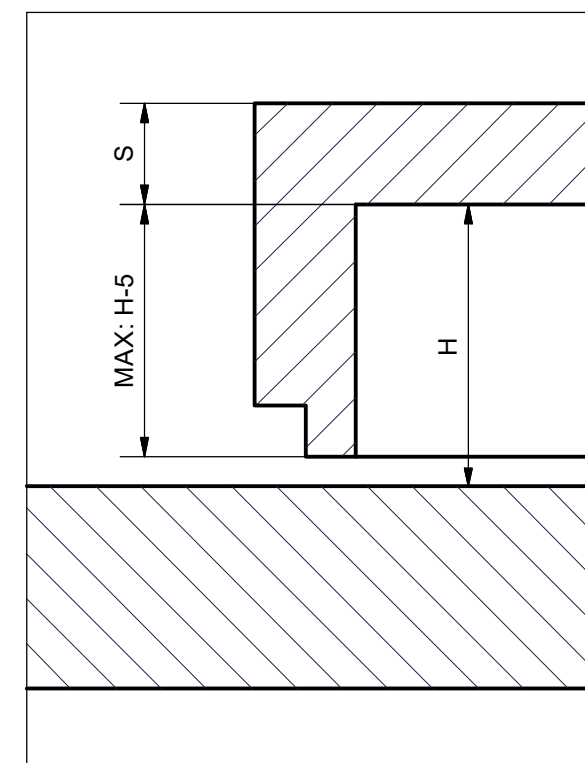

# POSIZIONE FORI FISSAGGIO MECCANISMO

## HOLES FOR MECHANISM POSITION

MODELLO / MODEL:

411/78.1241.22

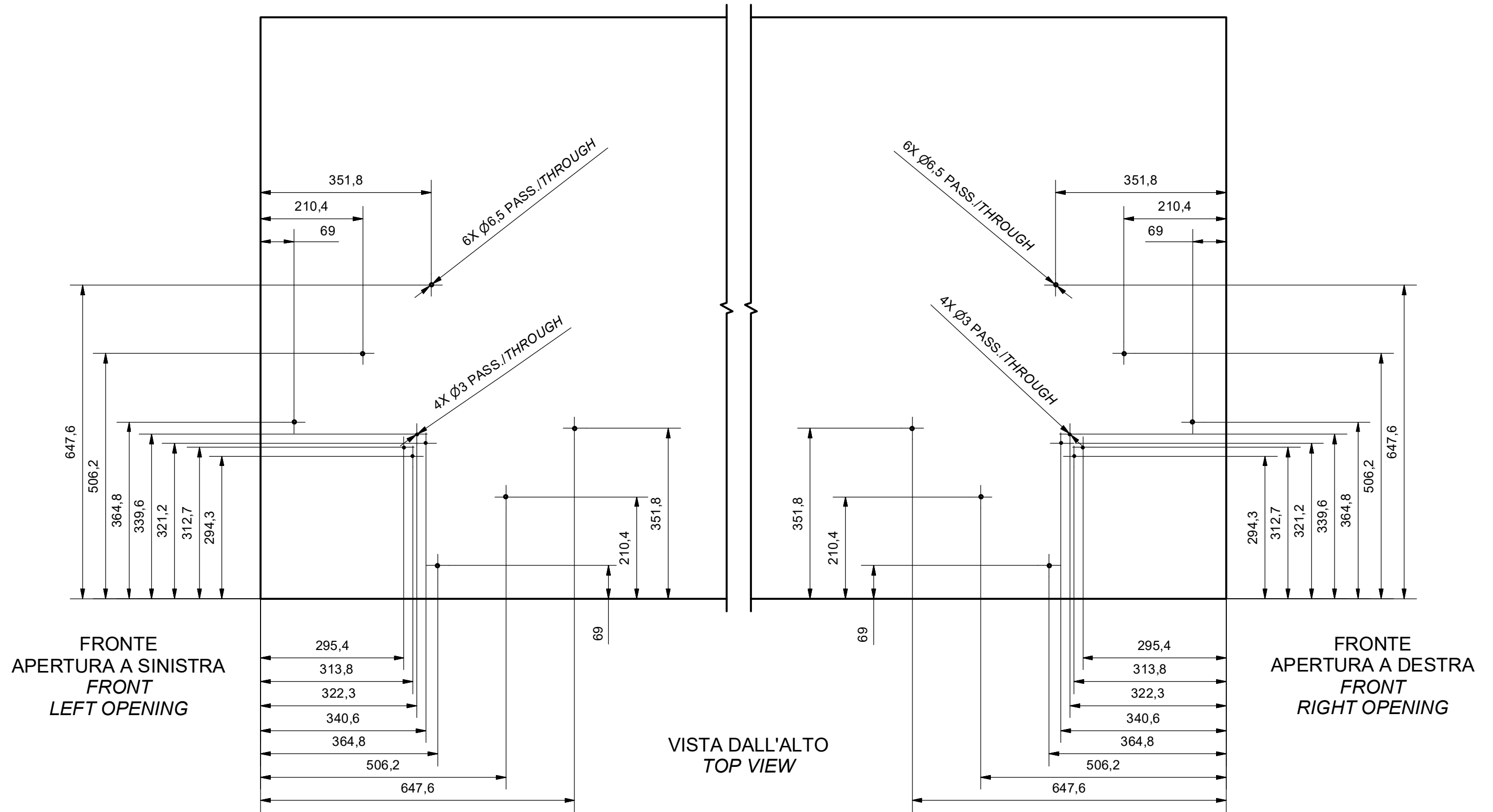

# POSIZIONE FORI FISSAGGIO MECCANISMO

## HOLES FOR MECHANISM POSITION

MODELLO / MODEL:

411/78.1242.22

411/78.1243.22

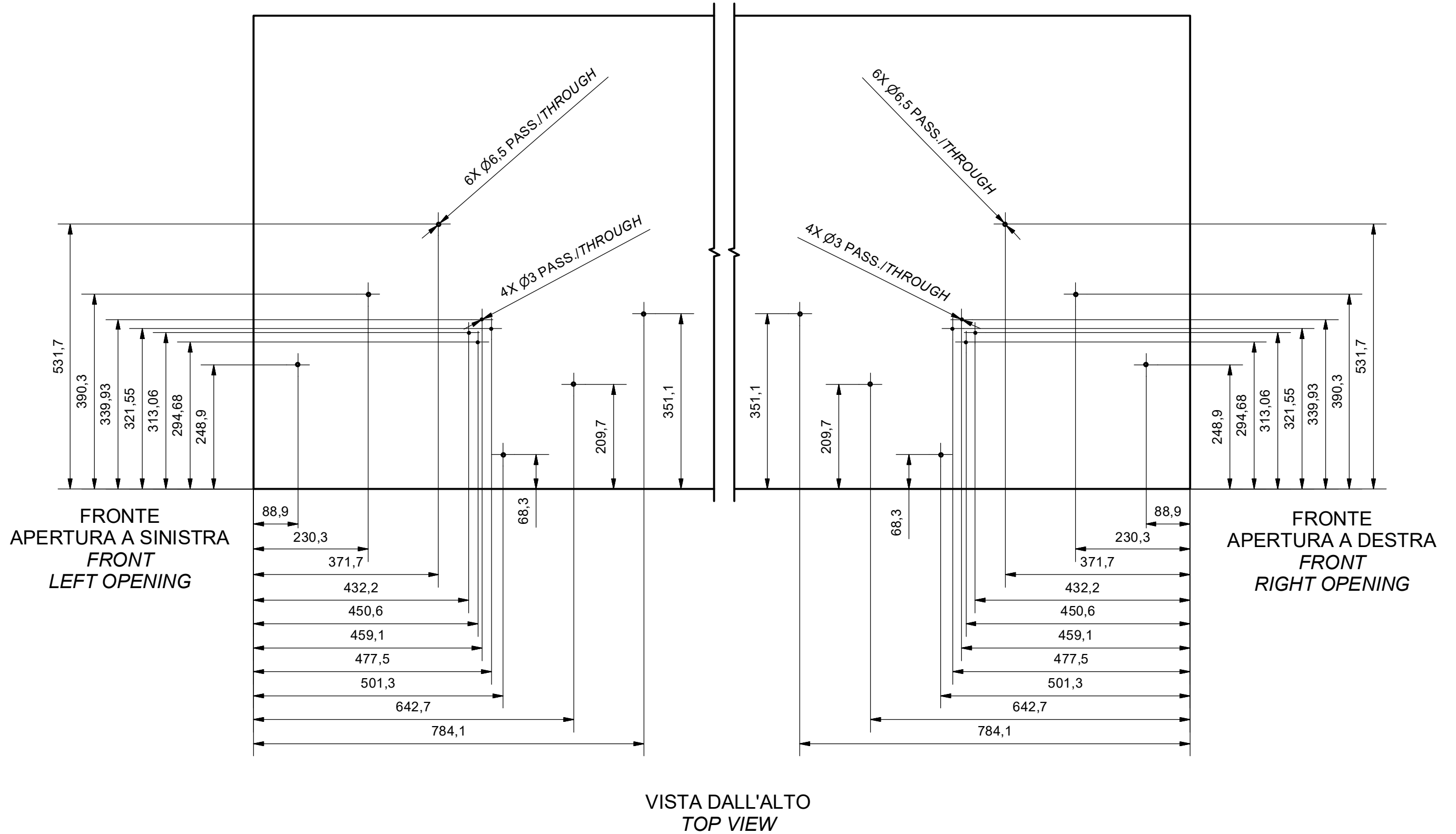

# DIMENSIONI PIANO PLANE DIMENSIONS

MODELLO / MODEL:

411/78.1241.22

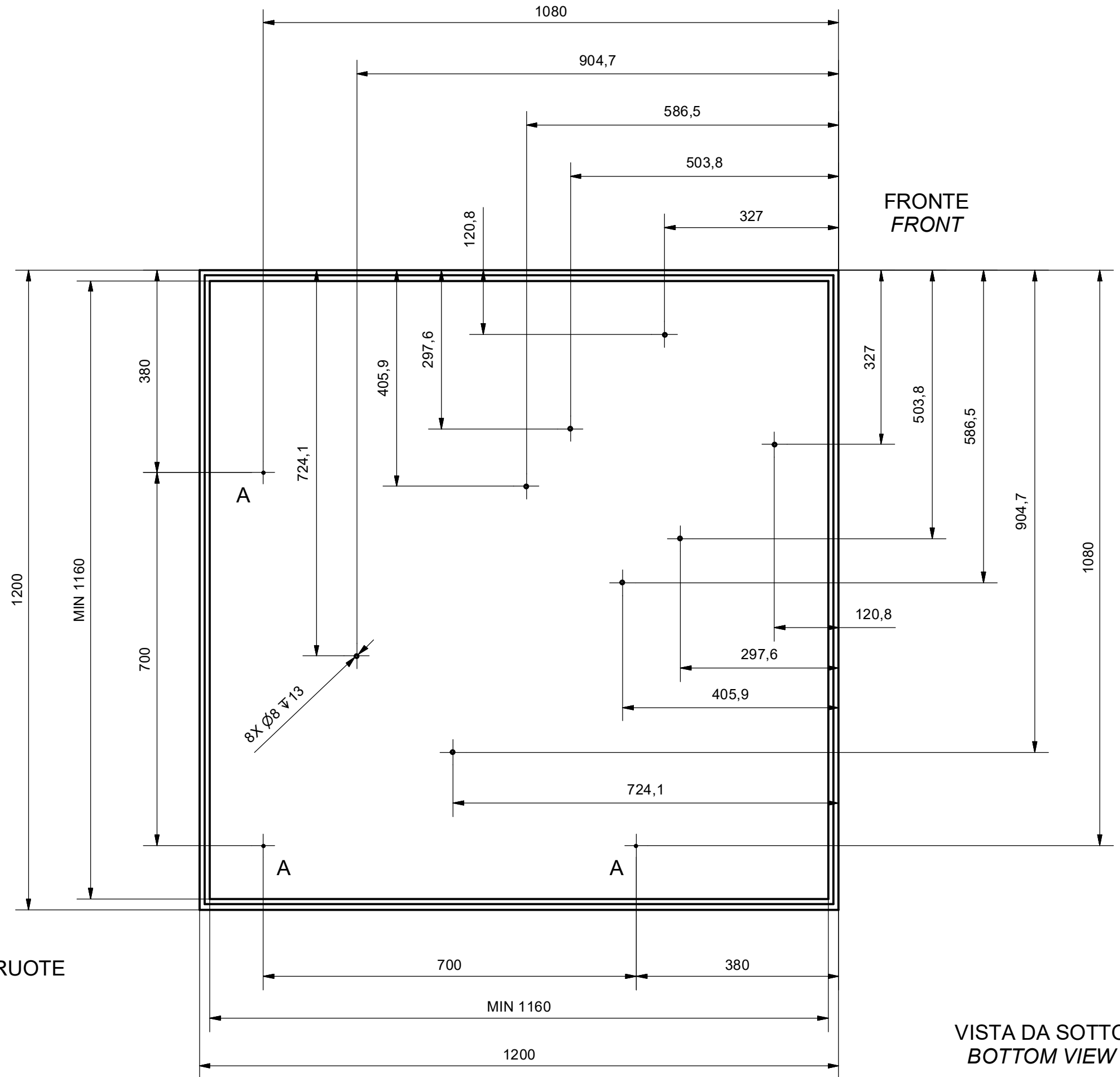
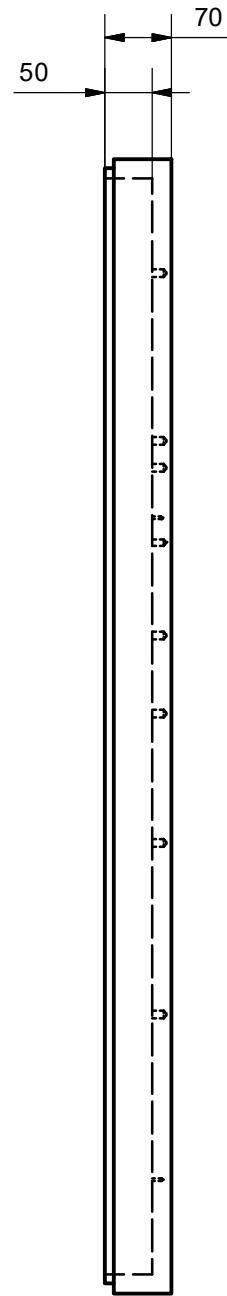

FRONTE  
FRONT

A: POSIZIONE SUGGERITA PER POSIZIONE RUOTE

A: POSITION WHEELS SUGGESTED

VISTA DA SOTTO  
BOTTOM VIEW

# DIMENSIONI PIANO PLANE DIMENSIONS

MODELLO / MODEL:

411/78.1242.22

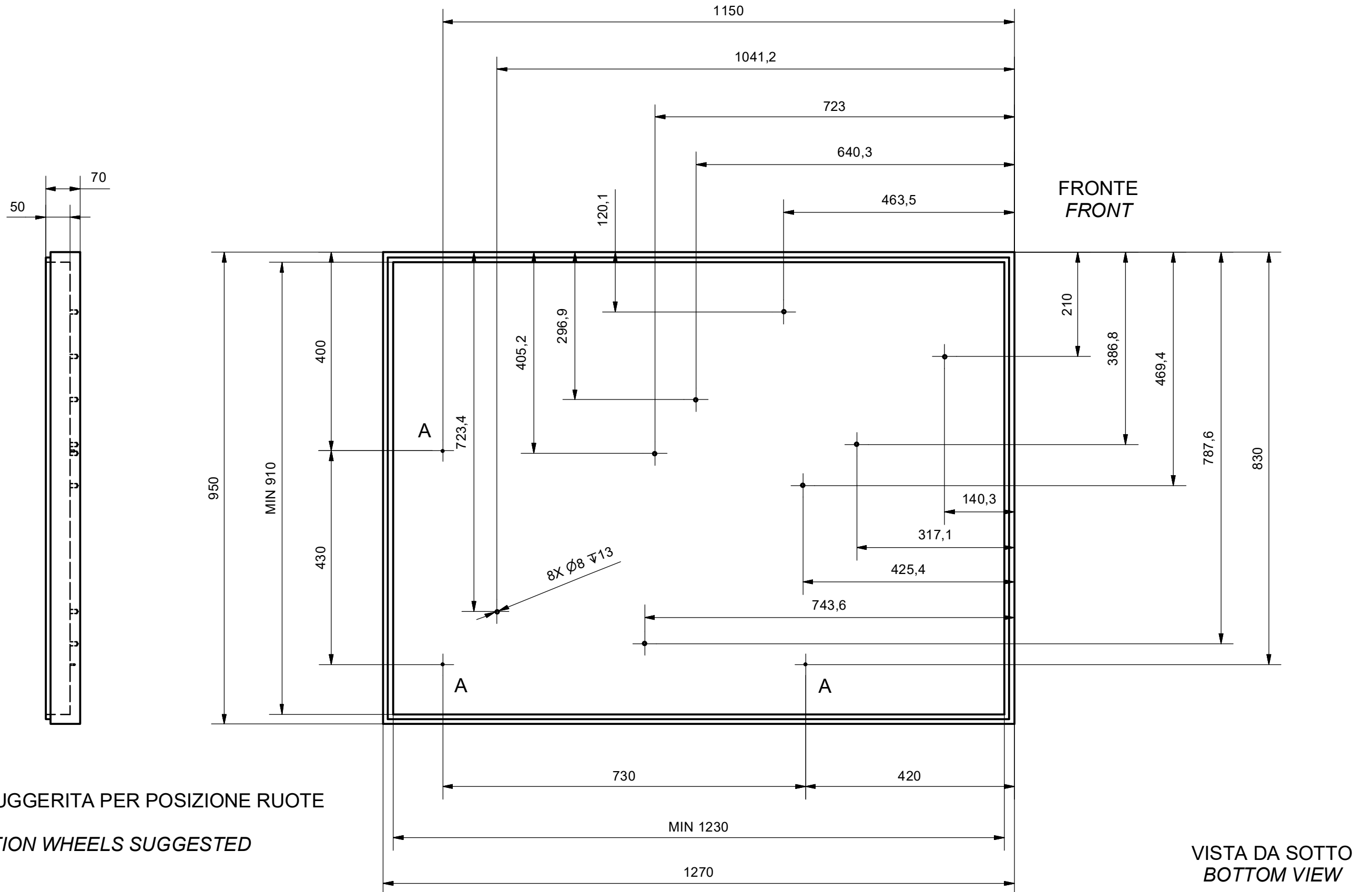

# DIMENSIONI PIANO PLANE DIMENSIONS

MODELLO / MODEL:

411/78.1243.22

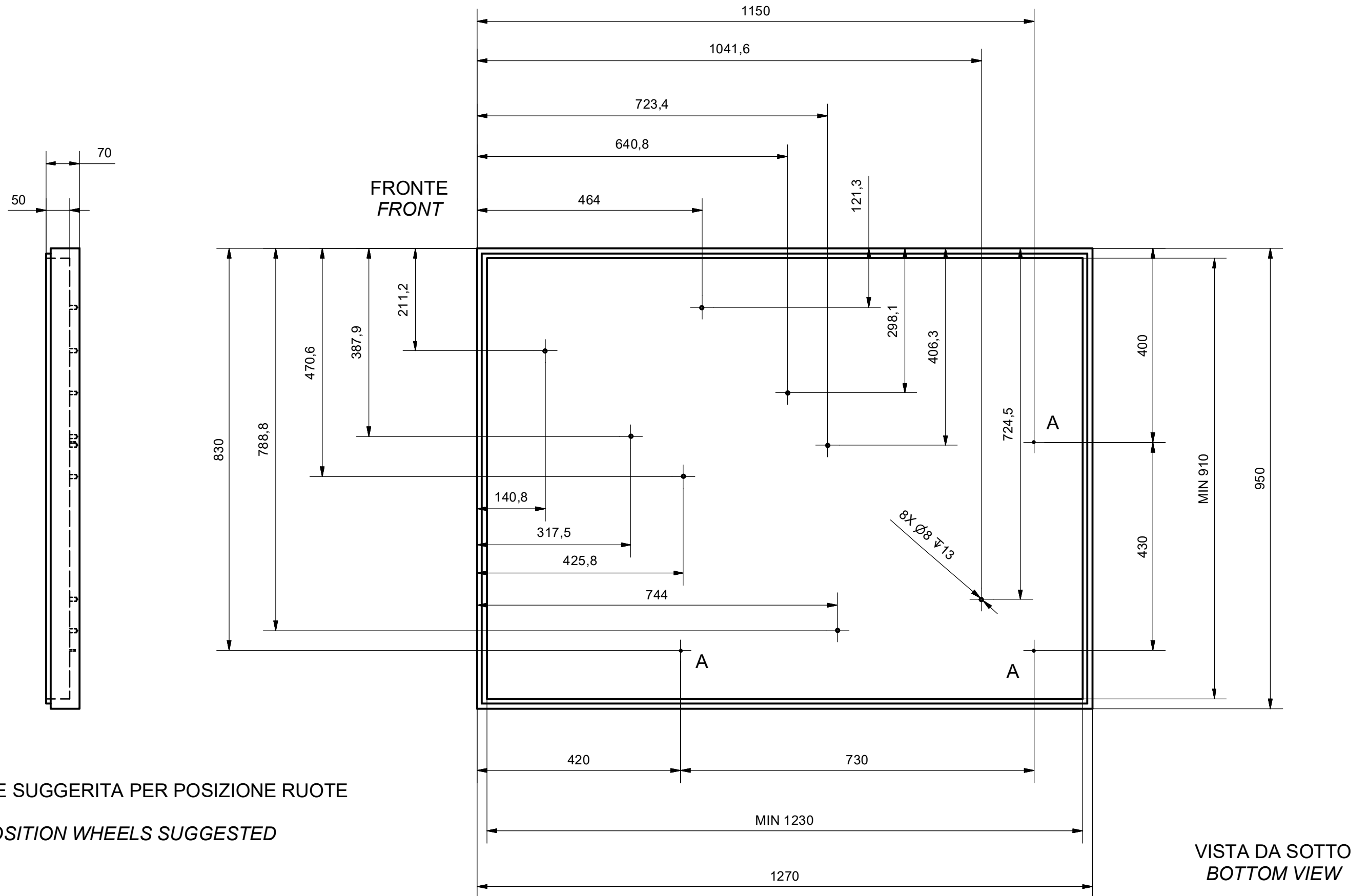

A: POSIZIONE SUGGERITA PER POSIZIONE RUOTE

A: POSITION WHEELS SUGGESTED

VISTA DA SOTTO  
BOTTOM VIEW

# MONTAGGIO DEL MECCANISMO

## MOUNTING OF THE MECHANISM

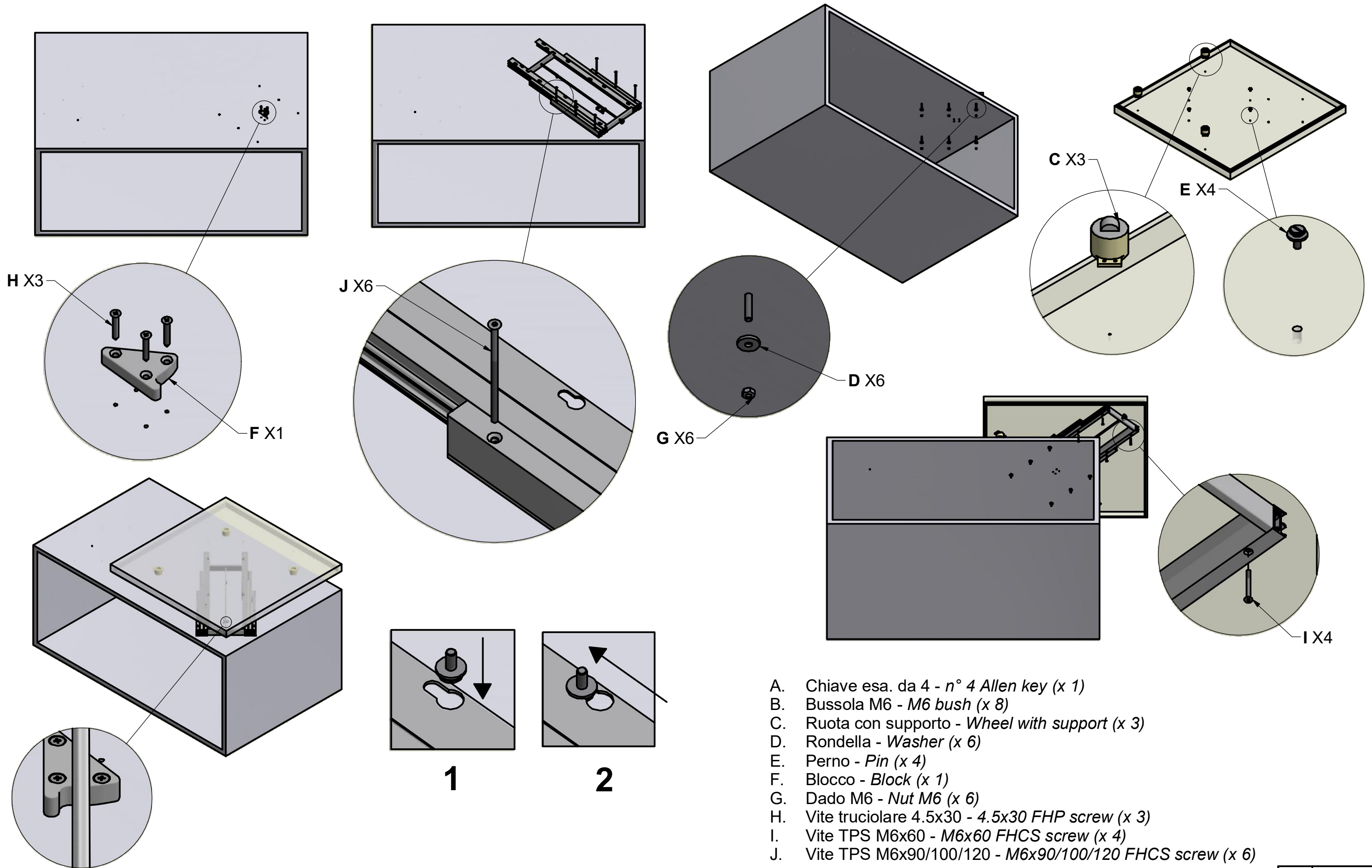

- A. Chiave esa. da 4 - n° 4 Allen key (x 1)
- B. Bussola M6 - M6 bush (x 8)
- C. Ruota con supporto - Wheel with support (x 3)
- D. Rondella - Washer (x 6)
- E. Perno - Pin (x 4)
- F. Blocco - Block (x 1)
- G. Dado M6 - Nut M6 (x 6)
- H. Vite truciolare 4.5x30 - 4.5x30 FHP screw (x 3)
- I. Vite TPS M6x60 - M6x60 FHCS screw (x 4)
- J. Vite TPS M6x90/100/120 - M6x90/100/120 FHCS screw (x 6)