

Maße | Dimensions | Dimensions

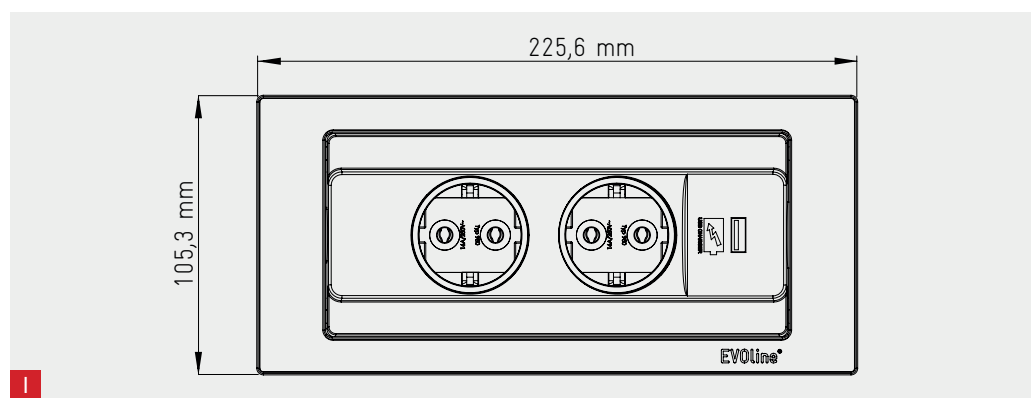

Edelstahl | Stainless Steel | Acier inox
Lackiert | Lacquered | Laqué

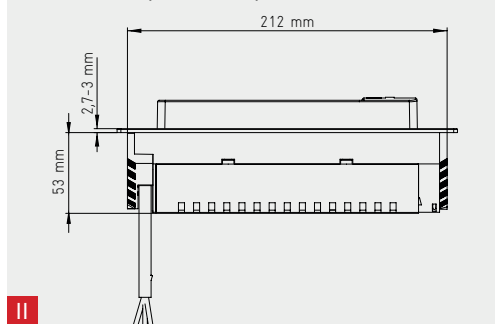

Glas | Glass | Verre
Keramik | Ceramics | Céramique

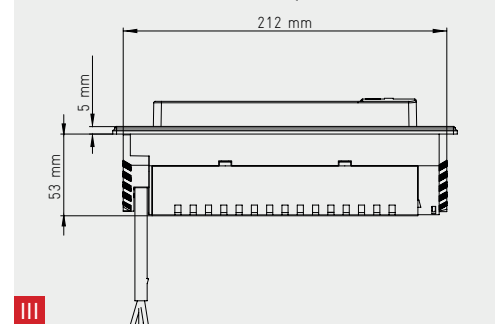

Ausschnittmaße | Cutout Dimensions | Dimensions

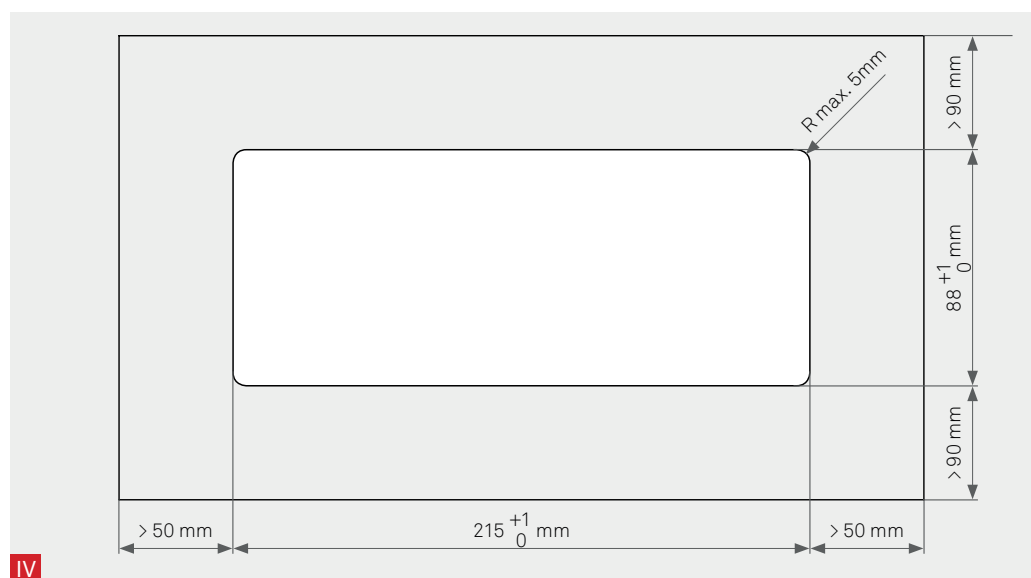

Fräsmaß Flächenbündig | Milling dimension: Flush Mounting | Dimension de fraisage Montage Affleurant

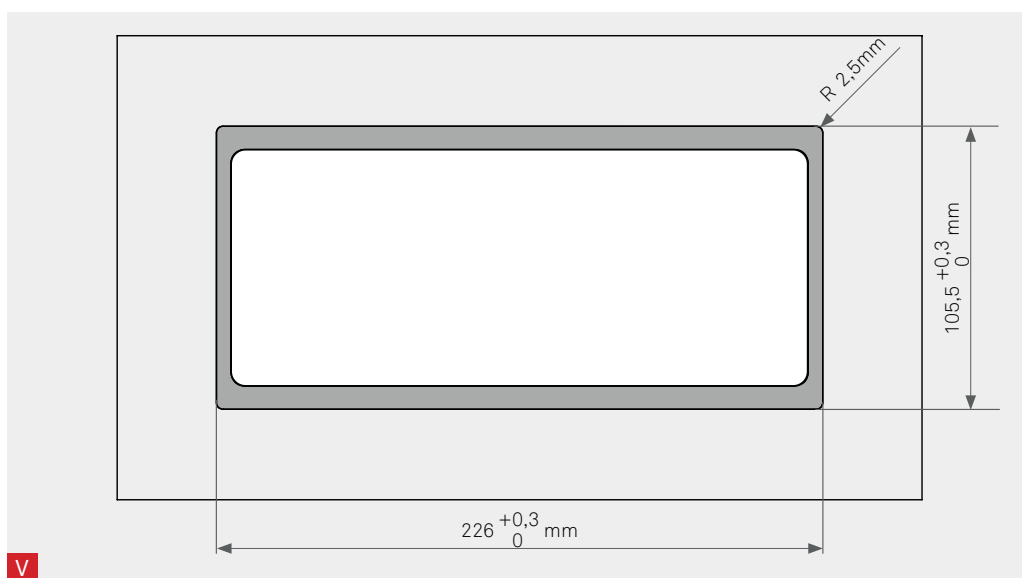

Frästiefe bei flächenbündigem Einbau | Milling depth for flush installation | Profondeur de fraisage pour montage affleurant

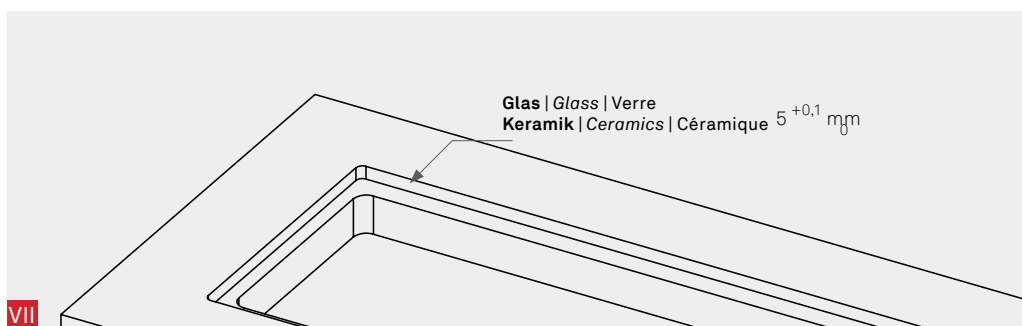
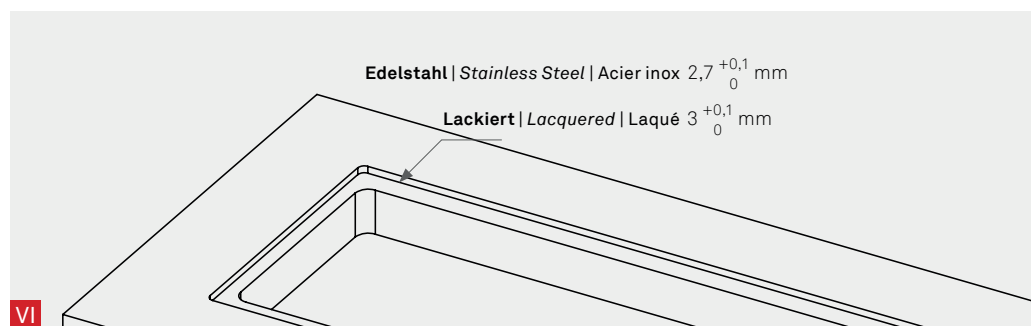

Einbauanleitung | Installation Instructions | Guide d'installation

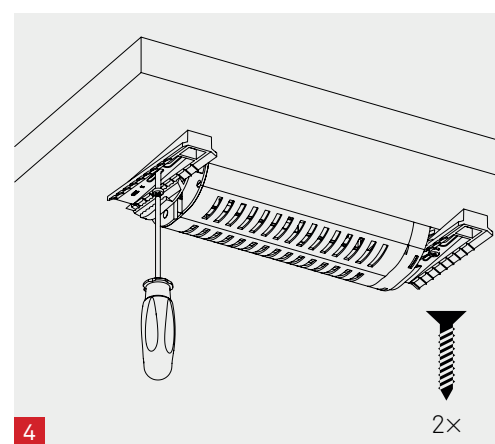
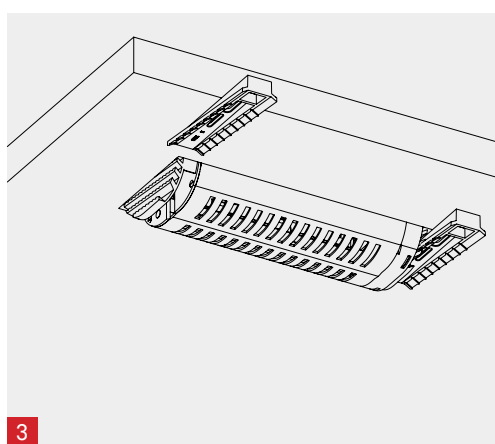
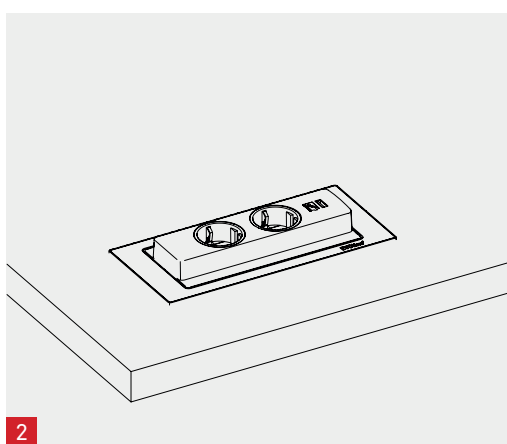
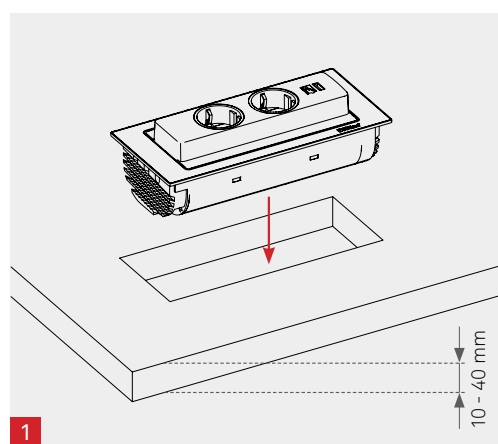

Bedienungsanleitung | User Guide | Mode d'emploi

