

Istruzioni di montaggio "DRIVE"

Included in this pack



1 Trolley

2 Bins

3 Optional Wire Handle

6 pcs 6x15mm screw

6 pcs spacers

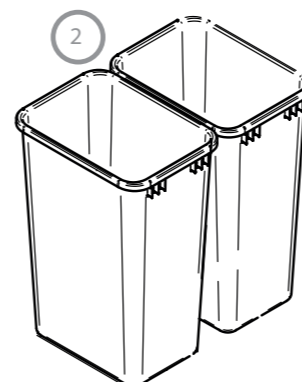
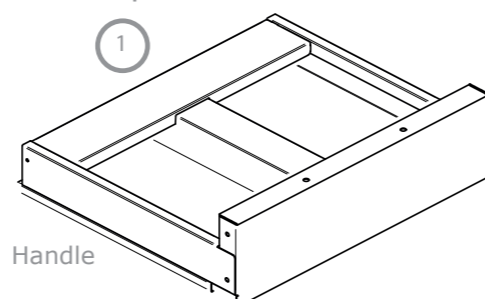

3

Bradawl

Cross Head Screwdriver

Meter

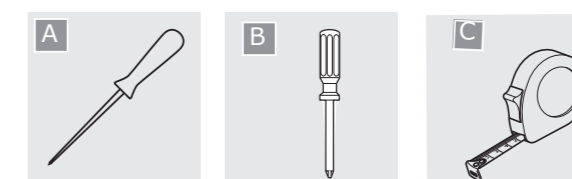

Herrajes técnicos para mobiliario



STEP 1

Screw the runner on the side board of the cabinet leaving 4mm open **(A)** from the front of the cabinet. Attention with side walls of 16 mm. **(B)** you need to insert spacers between the side board and the runners.

Avvitare le guide sul fianco del mobile lasciando 4mm. **(A)** dal fronte del mobile. Attenzione con fianchi di 16mm. **(B)** inserire i distanziali tra il fianco e la guida.

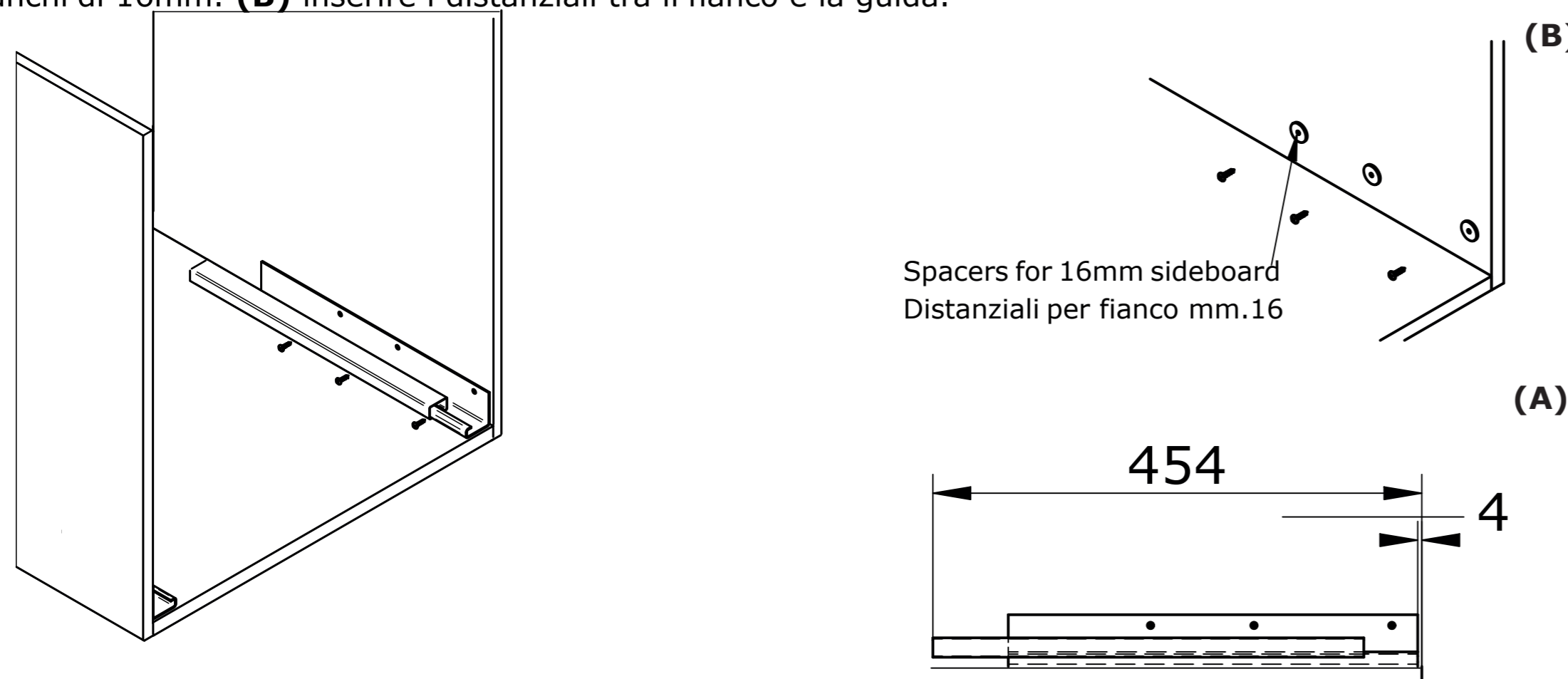

STEP 2

Fit the bin centered respect to the side board of the cabinet by locking it directly on the runners by pushing it toward the bottom of the cabinet the dustbin automatically locks onto the runners.

Inserire la pattumiera centrata rispetto ai fianchi del mobile appoggiandola direttamente sulle guida e spingendola verso il fondo del mobile la pattumiera si bloccherà automaticamente sulle guide.

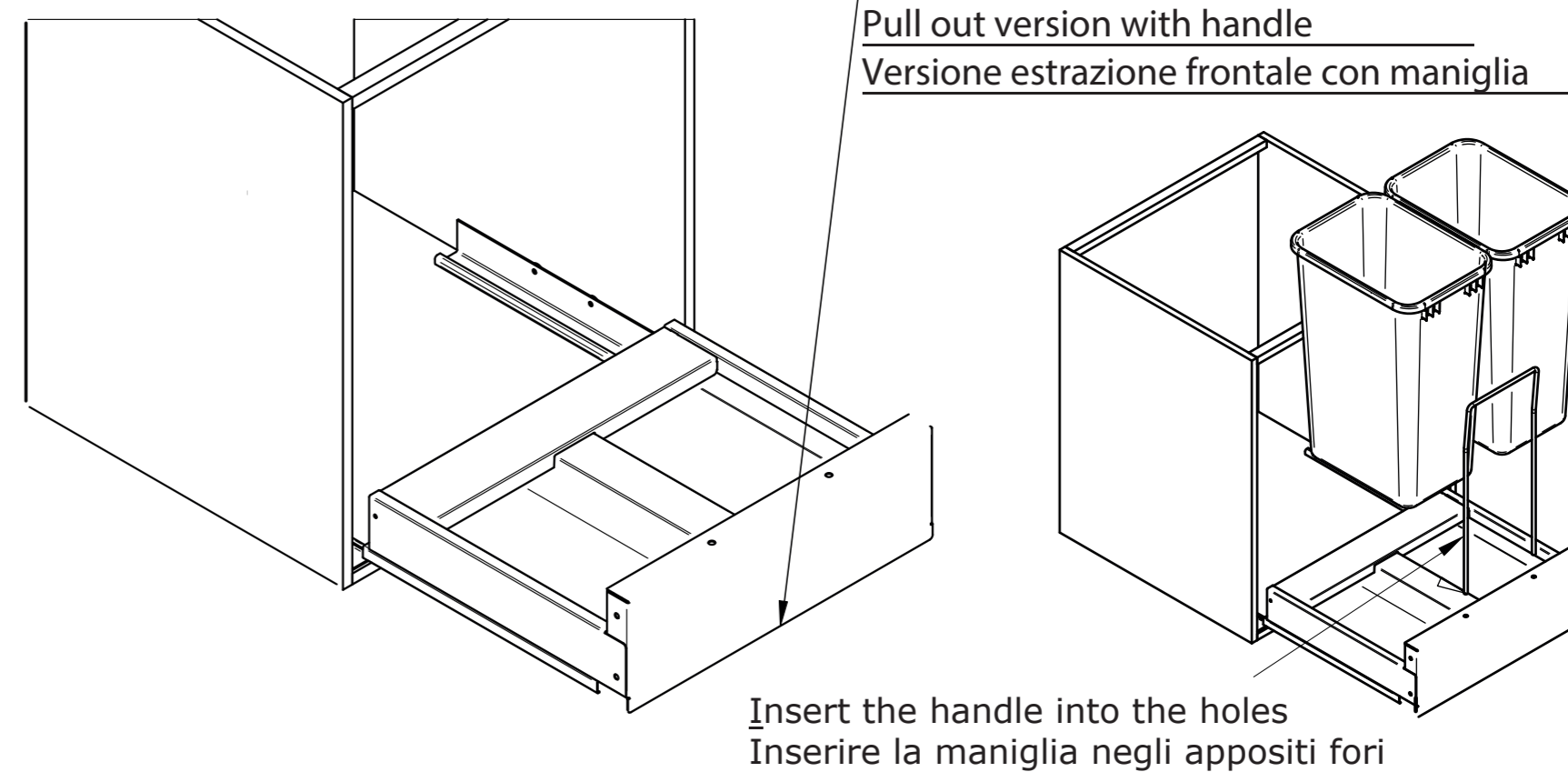

Insert the handle into the holes
Inserire la maniglia negli appositi fori

STEP 3 Versione con anta estraibile Door front fixed version

Fix the two brackets on the door according to the measurements as indicated, using 2 slots for each bracket. in this way it allows lateral adjustment of the door.

Fissare le 2 staffe sullo sportello secondo le misure indicate, utilizzando 2 asole per ogni staffa. in questo modo è possibile una regolazione laterale dello sportello.

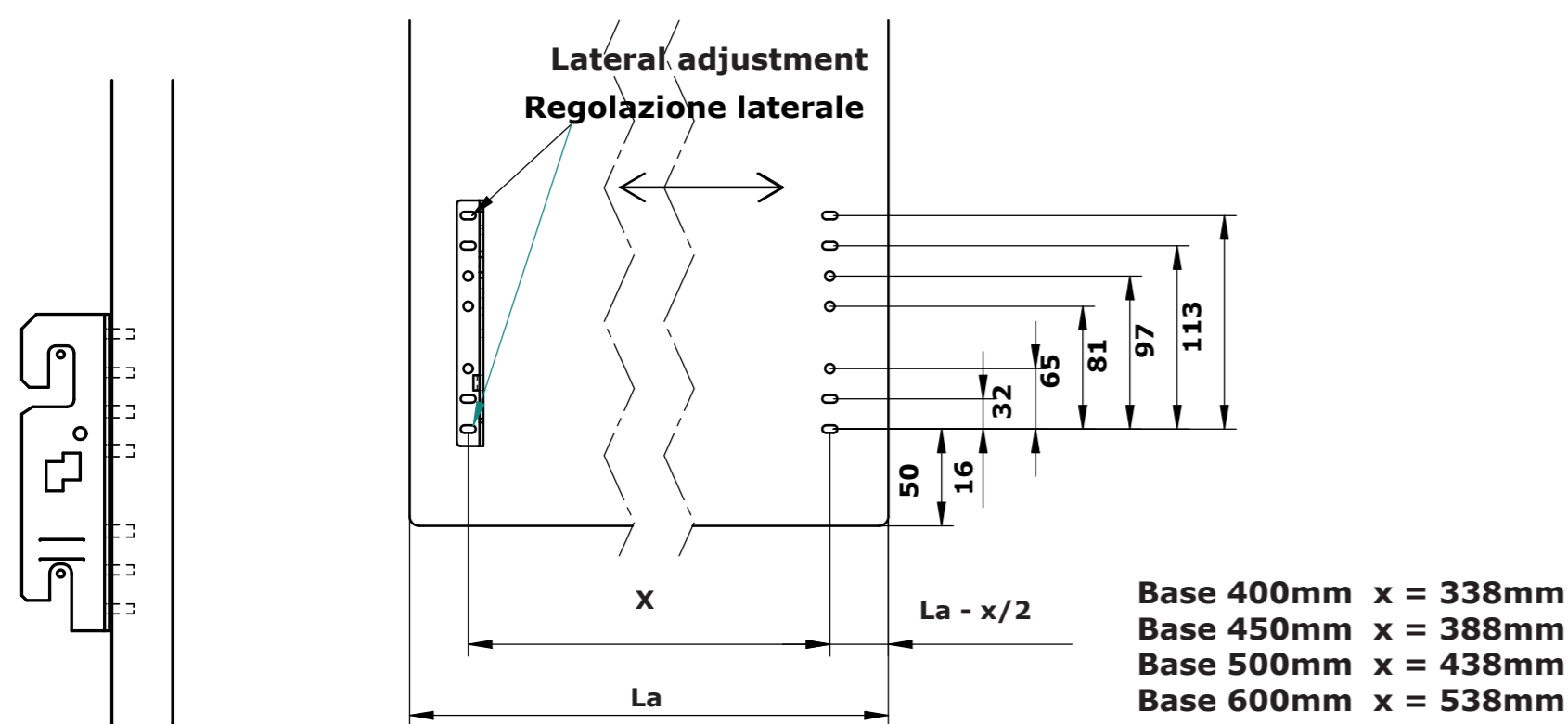

STEP 4

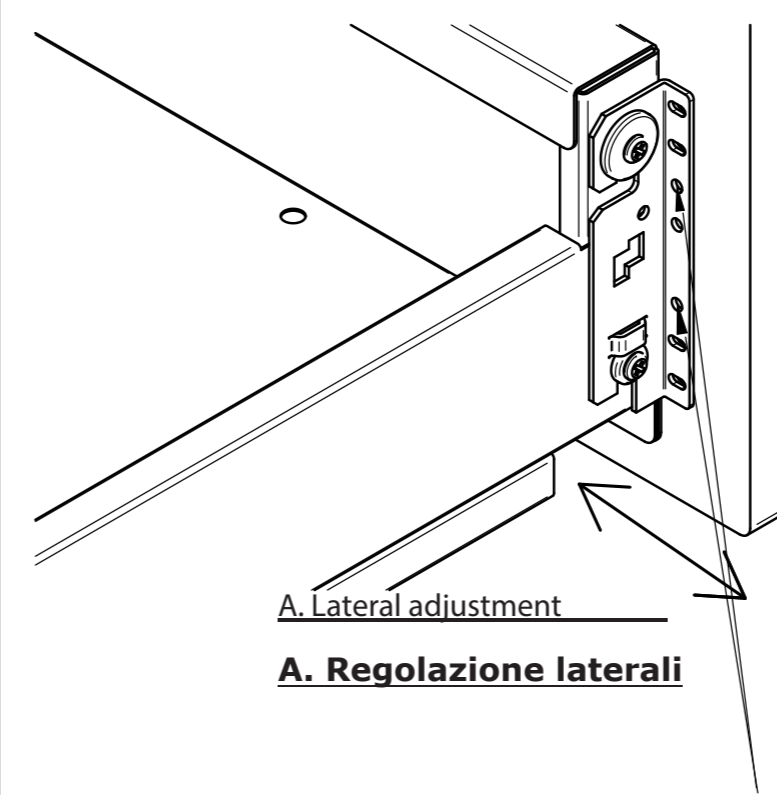

After all adjustments fix two screws for each bracket using the holes

Dopo tutte le regolazioni mettere 2 viti per ogni staffa utilizzando i fori.

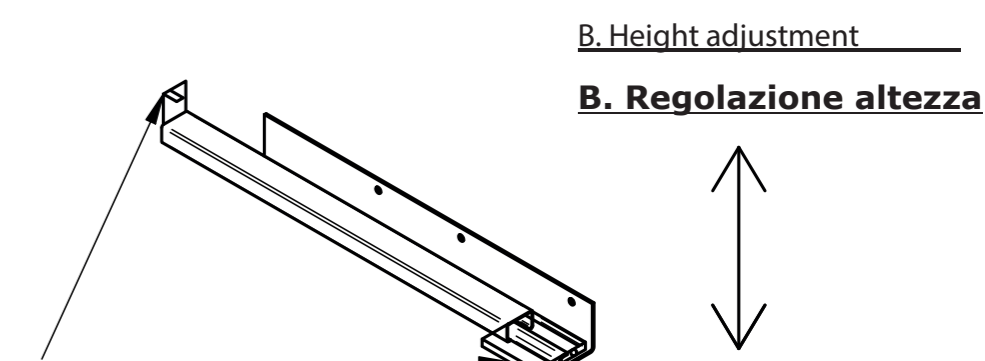

Use registers on the front and rear of the slider to raise and lower the door.

Utilizzare i registri anteriori e posteriori sulla guida per alzare ed abbassare lo sportello.

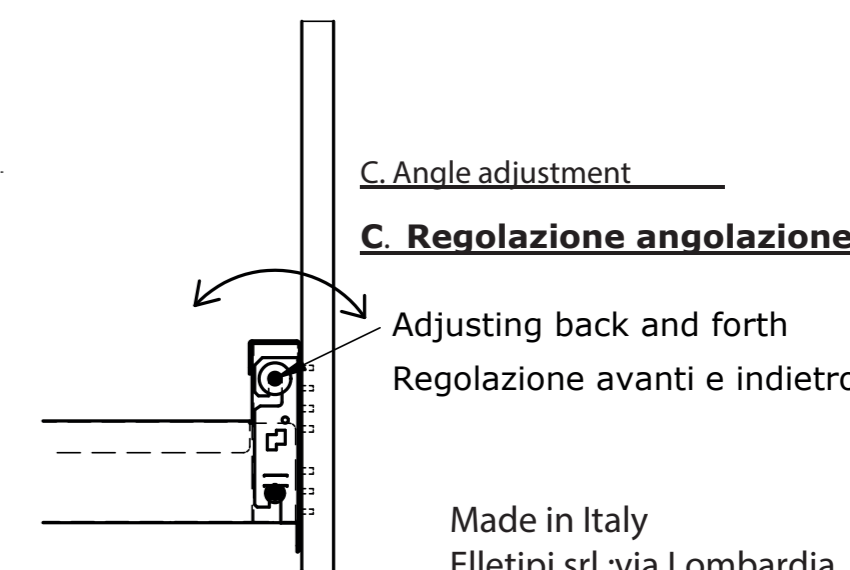

Adjusting back and forth
Regolazione avanti e indietro