

PF01 34A1  18 L 8 L	PF01 34A2  12 L 12 L
PF01 34A3  8 L 8 L 8 L	PF01 34B1  18 L 8 L 8 L
PF01 34B2  18 L 18 L	PF01 34B3  8 L 8 L 8 L 8 L
PF01 34C1  18 L	PF01 44B1  24 L 8 L 8 L
PF01 44B2  24 L 24 L	

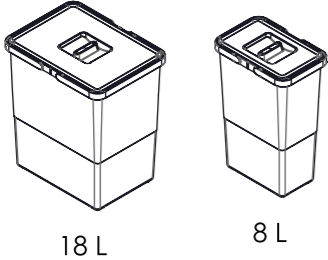
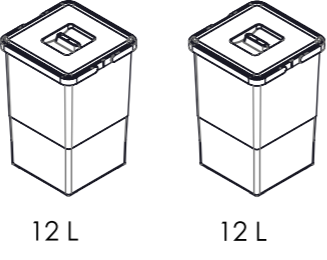
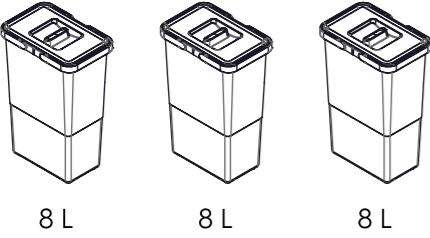
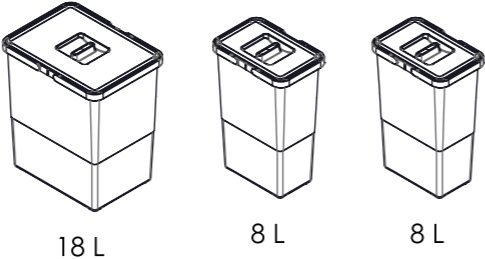
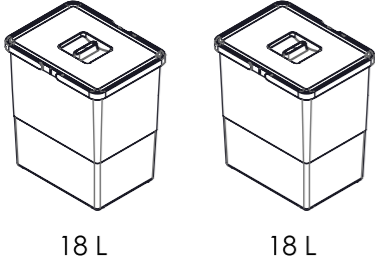
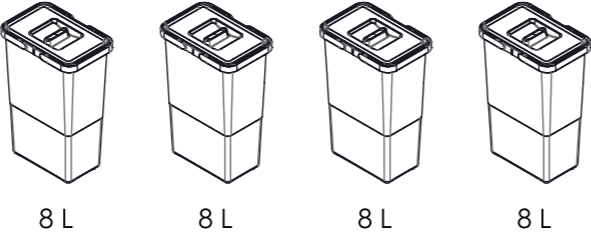
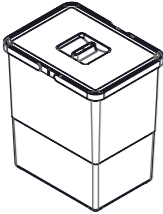
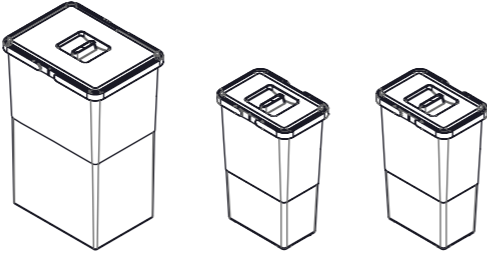
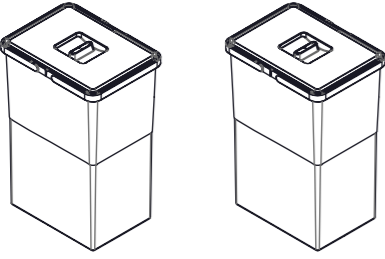
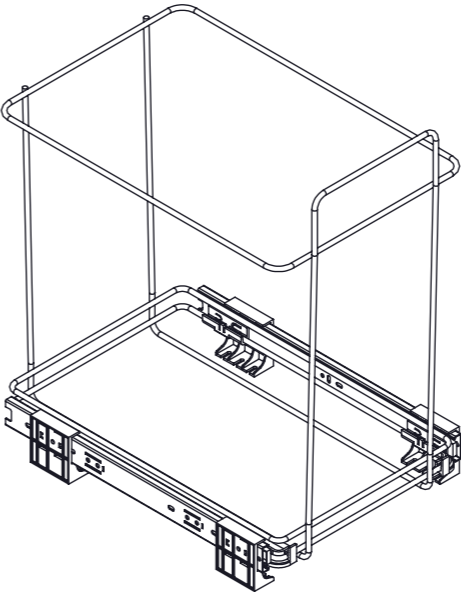
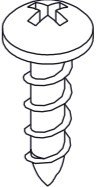
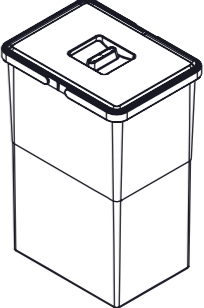

Herrajes técnicos para mobiliario

ECOFIL

COMPONENTS	
	 B (X4)
	 C (variable for each model)
A (X1)	

1

Base Drilling Layout

Place the bin in correct position as indicated and fix the 2 frontal screw

- PF01 34A : S1 = 200 mm , S2 = 290 mm
- PF01 34B : S1 = 280 mm , S2 = 290 mm
- PF01 34C : S1 = 200 mm , S2 = 190 mm
- PF01 44B : S1 = 270 mm , S2 = 290 mm

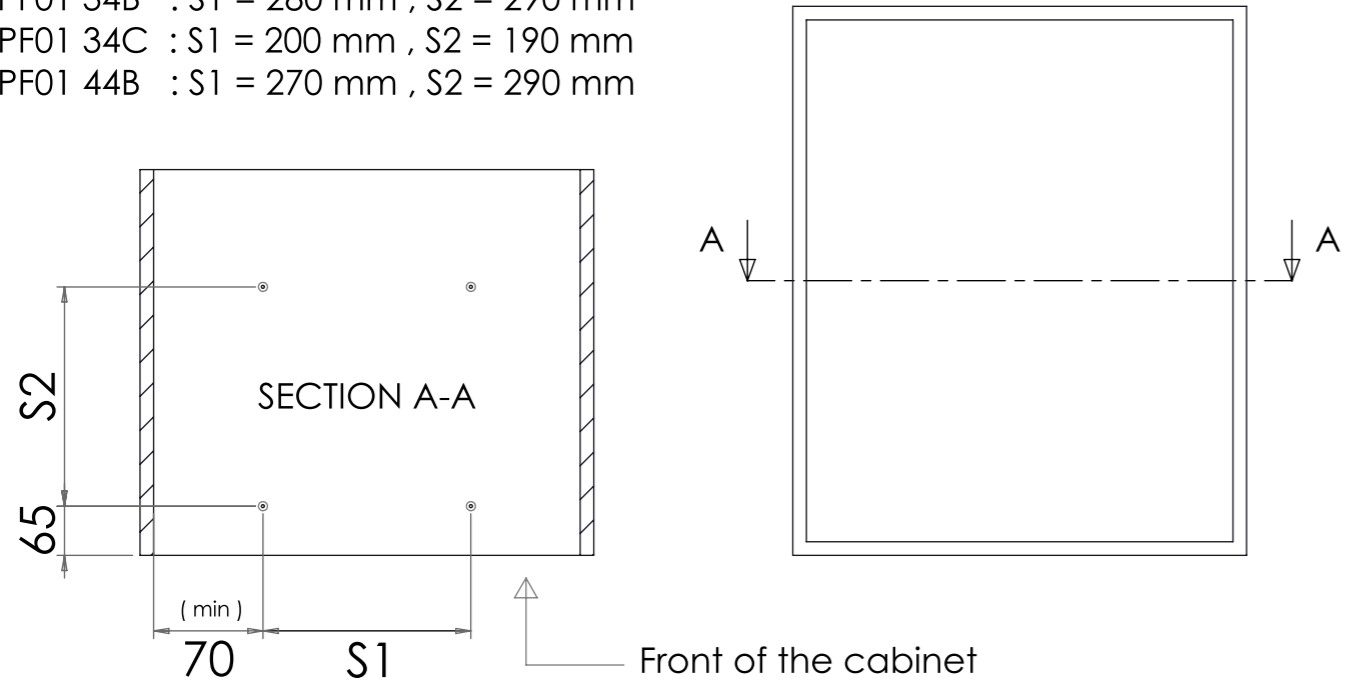

Front of the cabinet

2

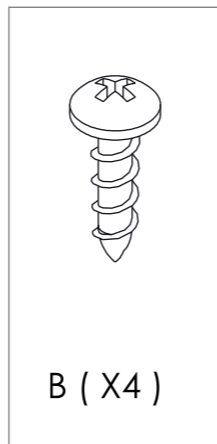
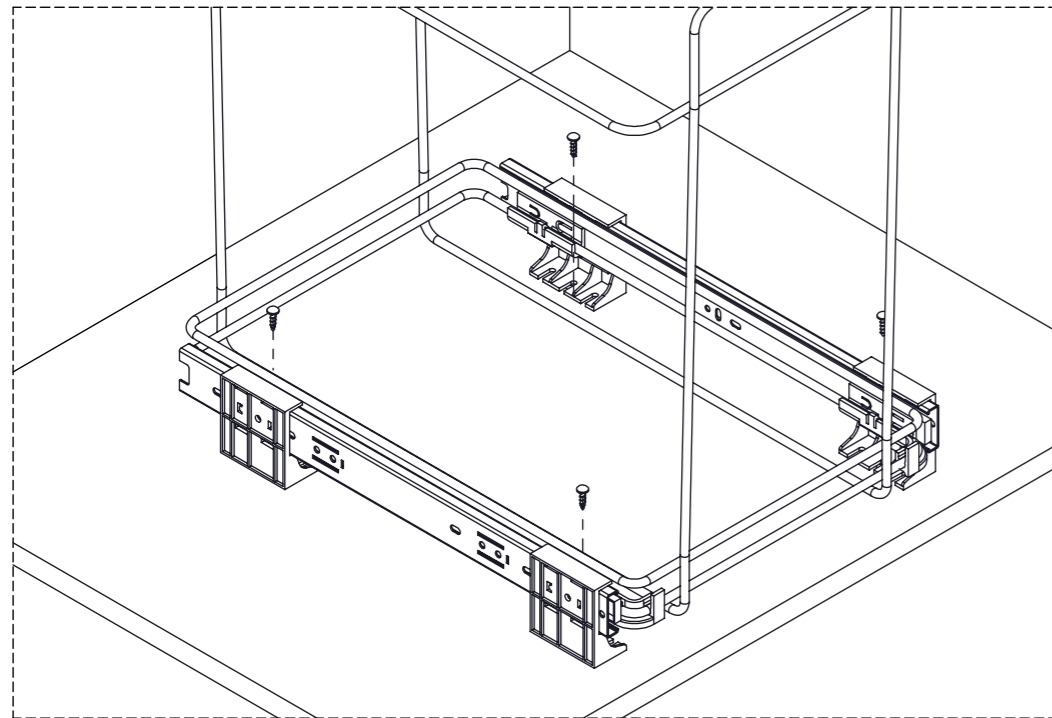

A (X1)

PF01 34A

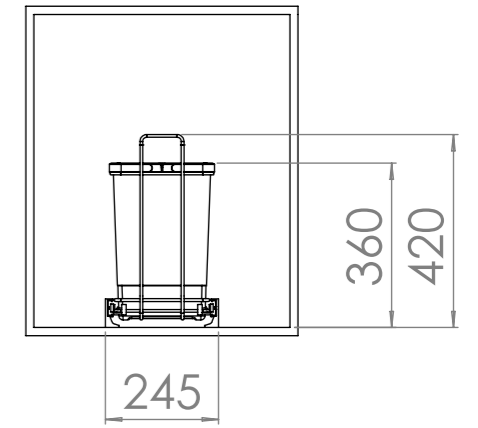
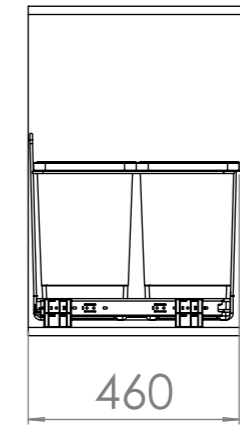
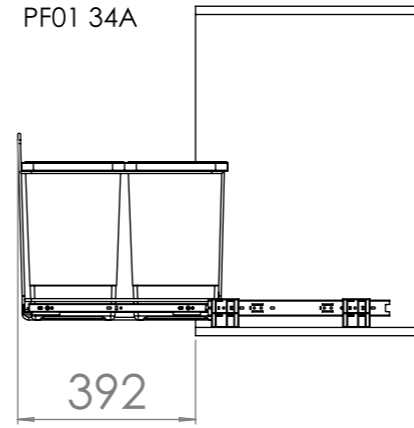

PF01 34B

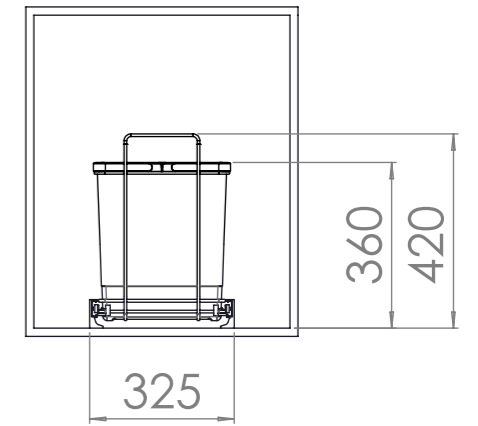
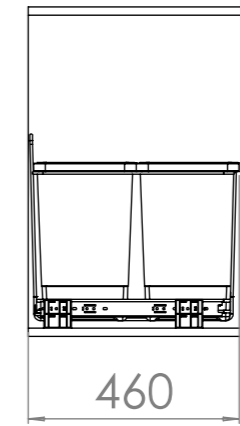
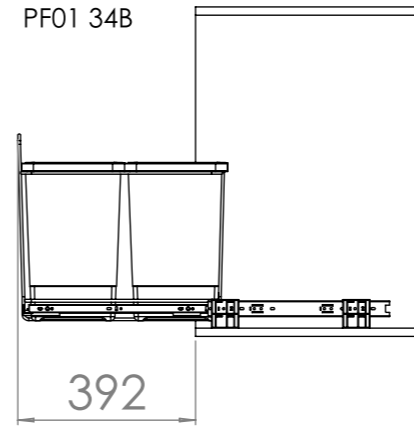

PF01 34C

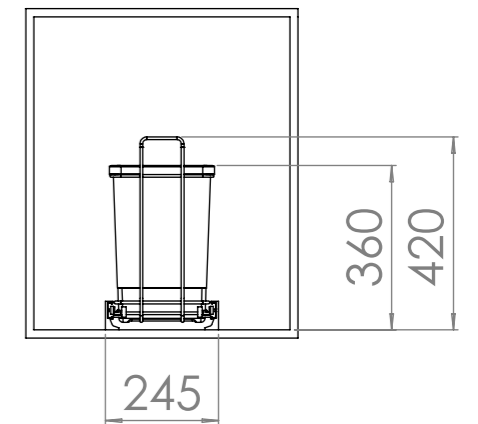
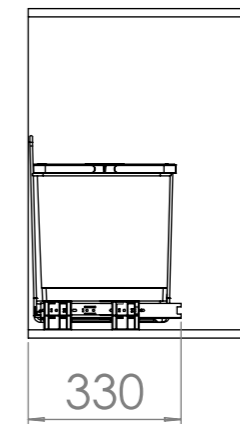
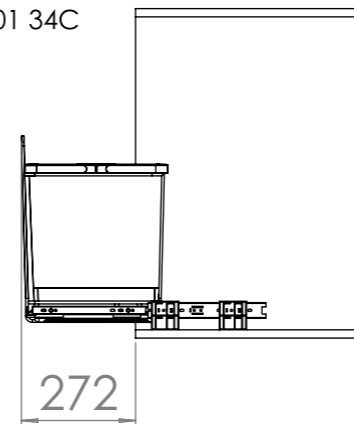

PF01 44B

