

4

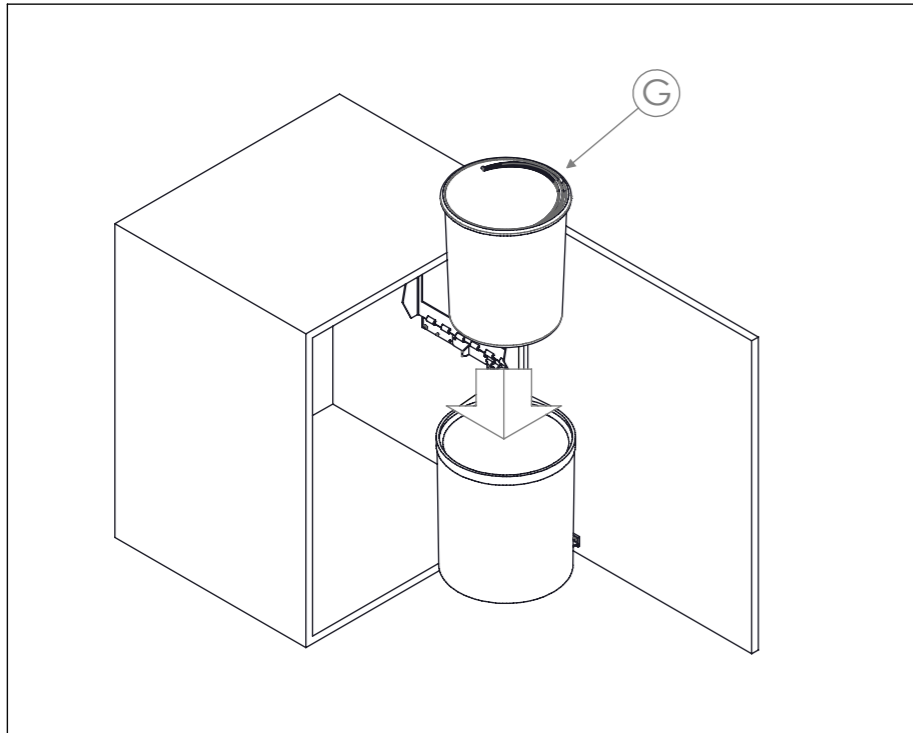

G (x1)



Herrajes técnicos para mobiliario

RING

COMPONENTS

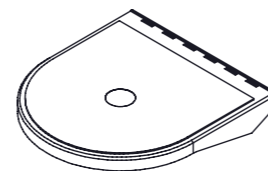

A (X1)

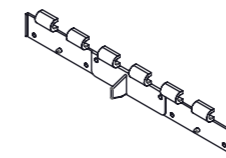

B (X1)



C (X1)

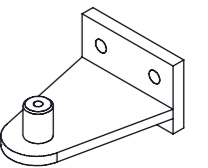

D (X1)

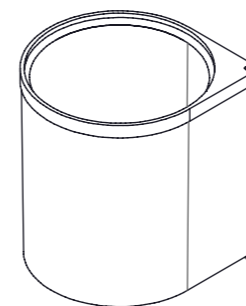

E (X1)



F (X1)



G (X1)

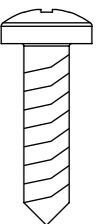

H (X7)

1

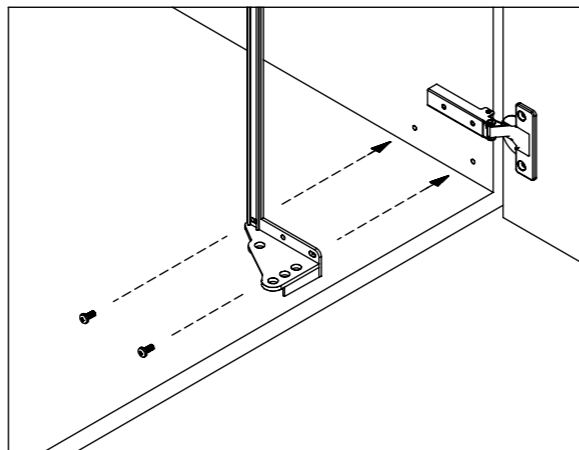
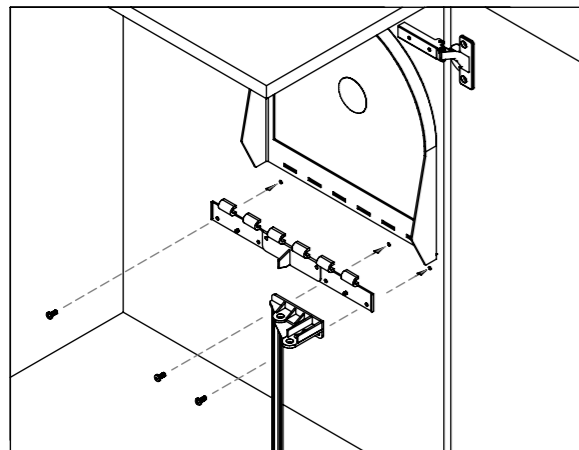
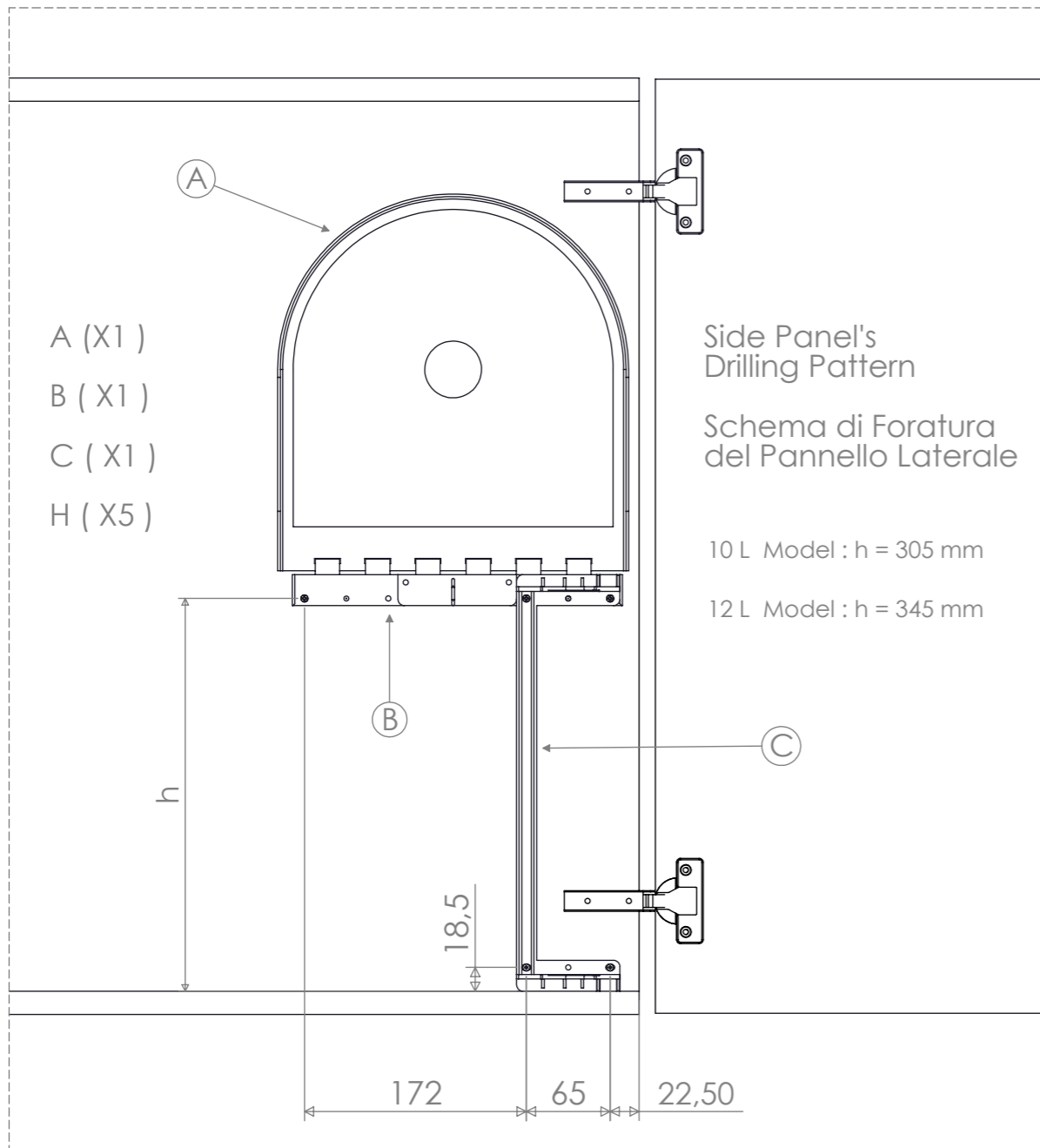

2

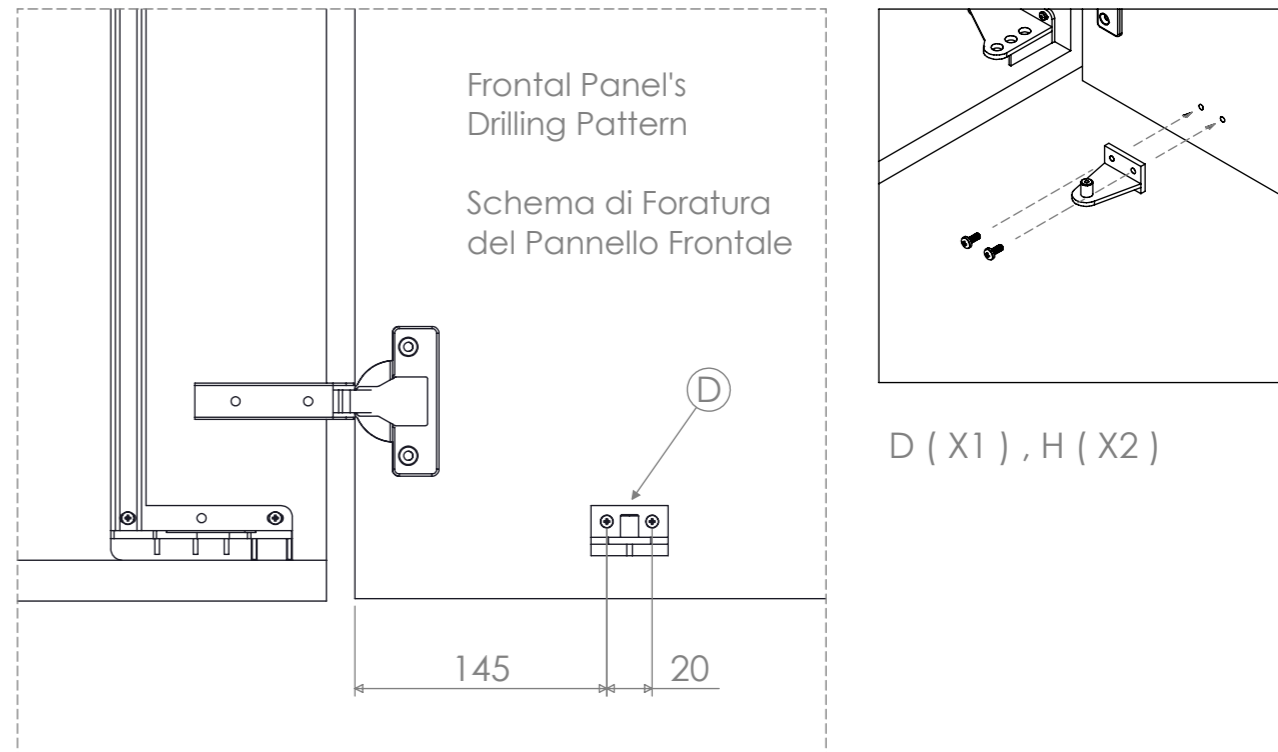

3

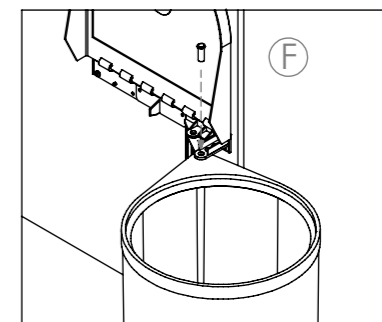
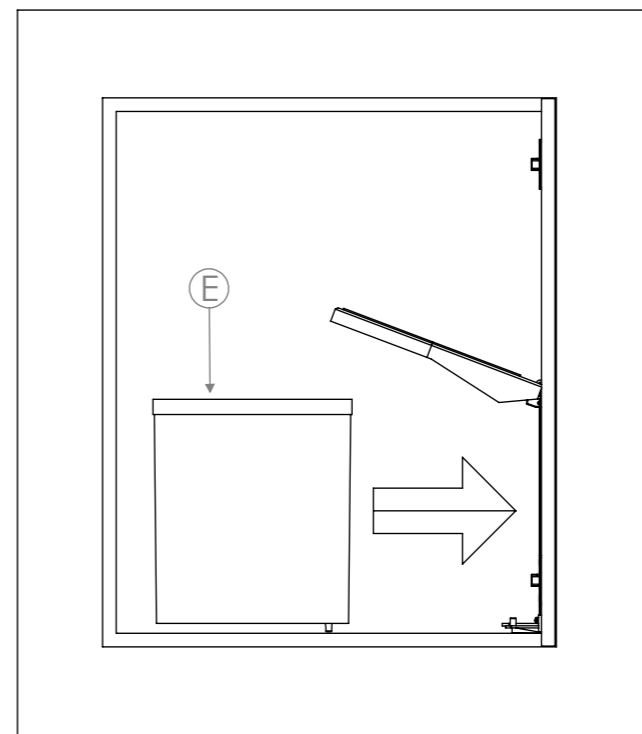

E (X1)
F (X1)

