

Exedra

Sistema per ante a scomparsa con movimenti di rientro laterale e di uscita ammortizzati e assistiti.

mechanism with damper-controlled door insertion and soft close action for door.

Einschubtürensysteem mit unterstützter Öffnungsbewegung und gedämpftem seitlichem Einzug.

Ferrure pour porte escamotable avec ouverture assistée par came et mouvement de la porte amorti.

escamoteables con movimientos de retorno lateral y de salida amortiguados y asistidos.

Sistema para portas retráteis com recolhimento lateral, saída amortizada e assistida.

**侧推隐藏门系统
内置凸轮助力机构，精确控制滑动运行，门板滑入、关闭双向阻尼。**

Cam-assisted pocket door

Sistema para puertas

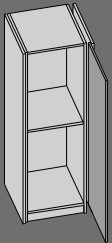

**Anta con apertura a destra
Right-hand opening door
Tür mit rechter Öffnung
Porte avec ouverture droite
Puerta con abertura a la derecha
Porta com abertura à direita
右开门**

SALICE

[ITA] ATTENZIONE

Destinato ad uso professionale.
Movimento con energia accumulata a molla, possibilità di movimento improvviso e incontrollato.
Vietato intervenire sui meccanismi se non adeguatamente formati ed informati.
In caso di necessità contattare l'assistenza.
Durante le operazioni di montaggio indossare idonei dispositivi di protezione degli occhi, delle mani e dei piedi.

[ENG] WARNING

For professional use only.
Spring-action mechanism may produce sudden, uncontrolled movement.
Do not attempt to work on the mechanism without prior training.
Technical assistance is available from your usual salice contact.
Always wear personal protective equipment for eyes, hand and feet.

[DEU] ACHTUNG

Für den gewerblichen einsatz.
Durch federunterstützte bewegung besteht die möglichkeit einer plötzlichen und unkontrollierten bewegung, die zu Verletzungen führen kann eine veränderung am beschlag darf nur durch ausreichend Geschultes fachpersonal erfolgen falls Unterstützung benötigt wird, kontaktieren sie bitte unseren technischen support während der montage ist geeignete schutzausrüstung für augen, hände und füsse zu tragen.

[FRA] ATTENTION

Pour usage professionnel.
Mouvement par ressort avec de l'énergie accumulée, possibilité de mouvements soudains et incontrôlés.
Ne pas intervenir sur des mécanismes sans formations et informations adéquates.
Si nécessaire, n'hésitez pas à contacter l'assistance.
Pendant l'assemblage, veuillez porter un équipement de protection appropriée pour les yeux, les mains et les pieds.

[SPA] ATENCIÓN

Destinado a uso profesional.
Movimiento a muelle con energía acumulada, posibilidad de movimiento imprevisto e incontrolado.
No intervenir en los mecanismos si no está adecuadamente entrenado e informado.
Si es necesario no dude en contactar con la asistencia.
Durante las operaciones de montaje, se ruega utilizar los dispositivos de protección para ojos, manos y pies.

[POR] ATENÇÃO

Destinado ao uso profissional.
Movimento com energia acumulada por mola, possibilidade de movimento repentino e não controlado.
Proibido intervir nos mecanismos se não estiver treinado e informado adequadamente.
Em caso de necessidade, entre em contato com a assistência.
Durante as operações de montagem, utilize equipamentos de proteção apropriados para os olhos, mãos e pés.

[ZH] 警告

此系统仅供专业人士操作。
弹簧机构可能会产生非受控的突发动作，未经预先培训，切勿擅自操作系统机构。
您日常联系的Salice工作人员，可为您提供技术支持服务。
请务必为眼、手、脚穿戴必要的个人防护用品。

[ITA] **Tipologia di montaggio**
1 ANTA

[ENG] **Types of assembly**
1 DOOR

[ESP] **tipos de montaje**
1 PUERTA

[DEU] **Montageart**
1 TÜR

[POR] **Tipologia de montagem**
1 PORTA

[FRA] **Types de montage**
1 PORTE

[ZH] **安装类型**
1 门

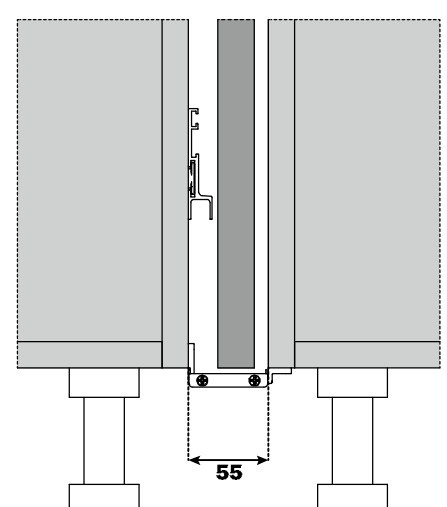
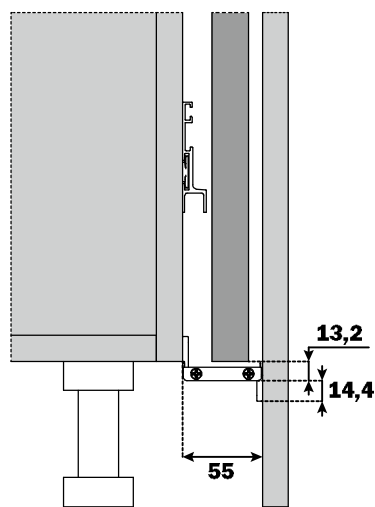
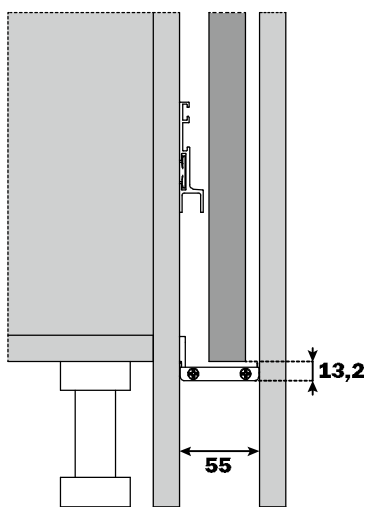
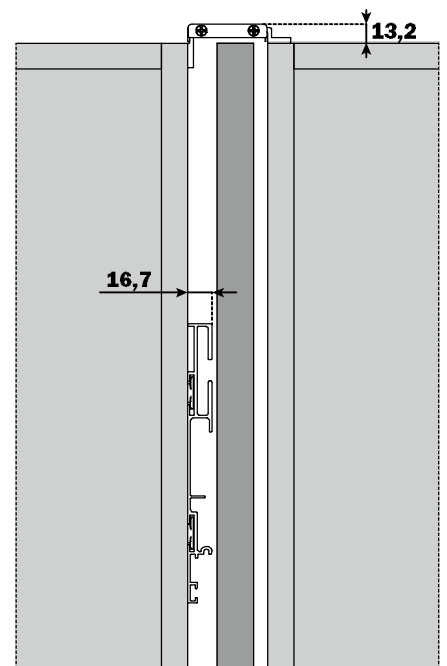
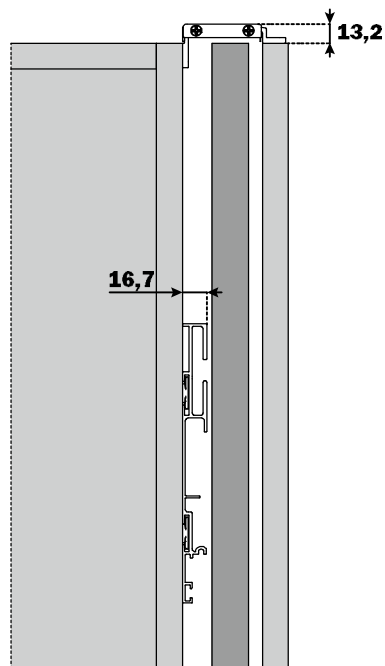
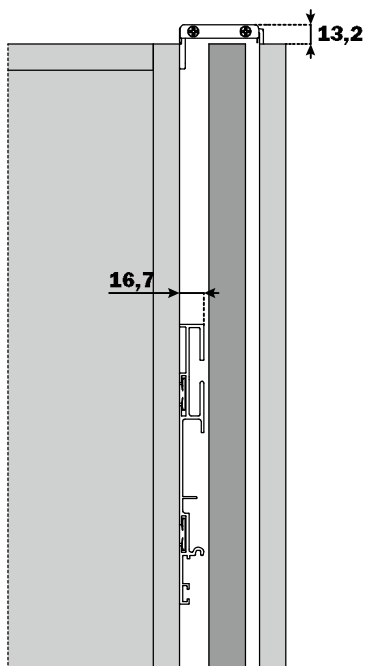

[ITA] **Tipologia di montaggio**
2 ANTE

[ENG] **Types of assembly**
2 DOORS

[ESP] **Tipos de montaje**
2 PUERTAS

[DEU] **Montageart**
2 TÜREN

[POR] **Tipologia de montagem**
2 PORTAS

[FRA] **Types de montage**
2 PORTES

[ZH] **安装类型**
2 门

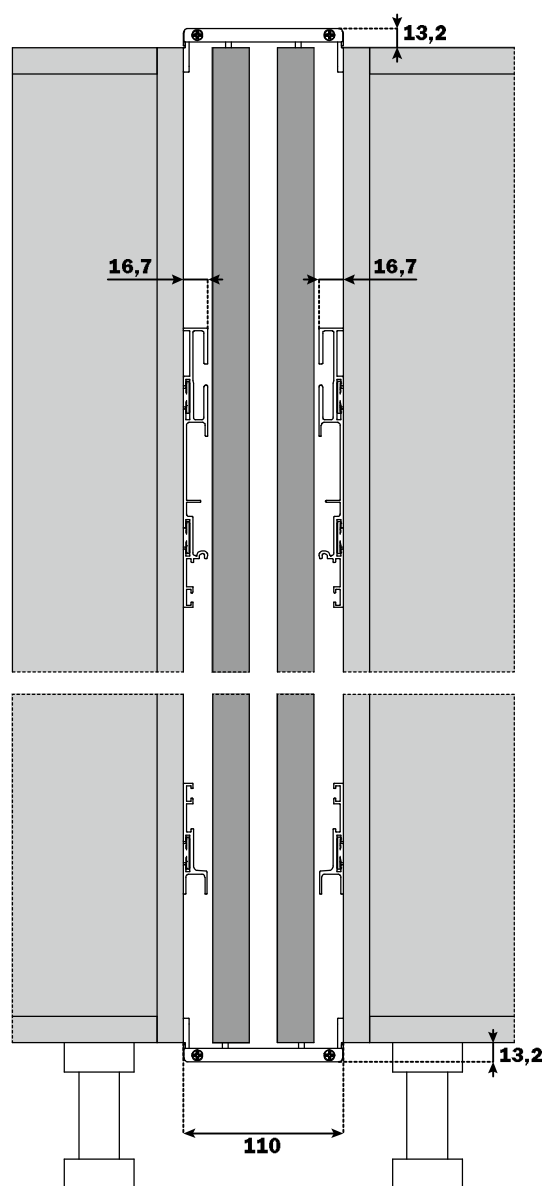
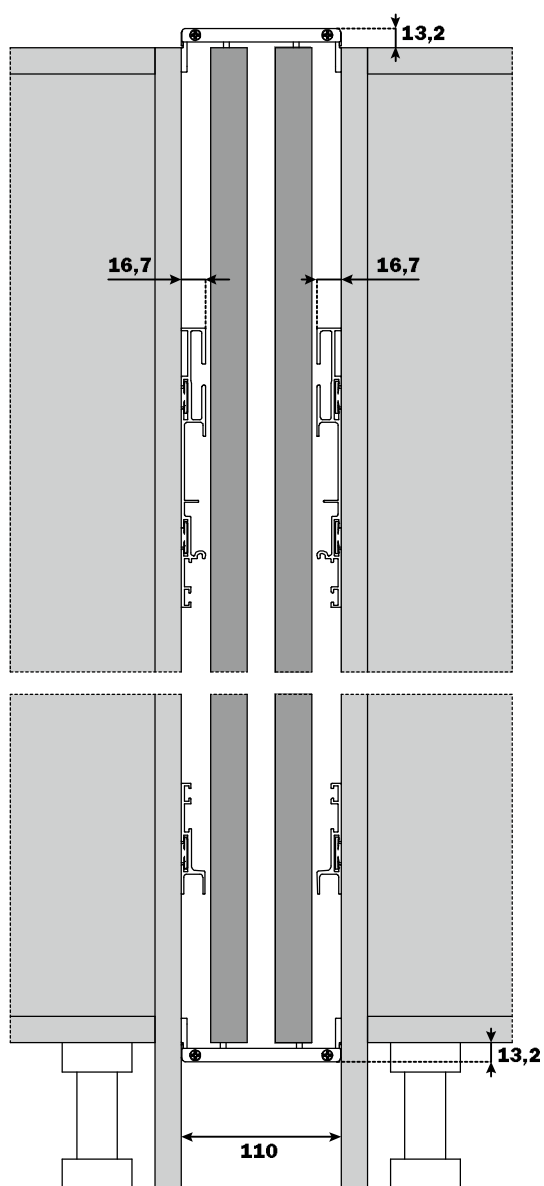

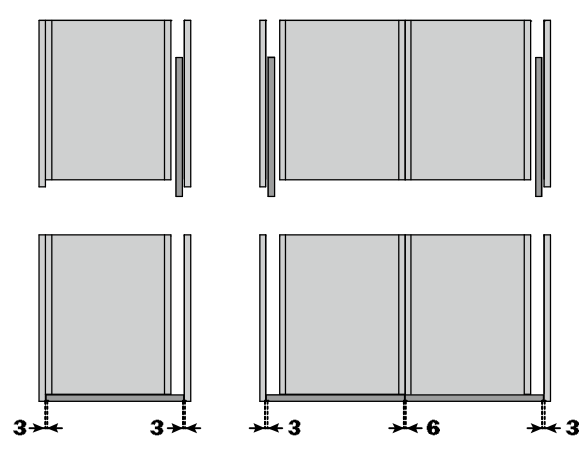
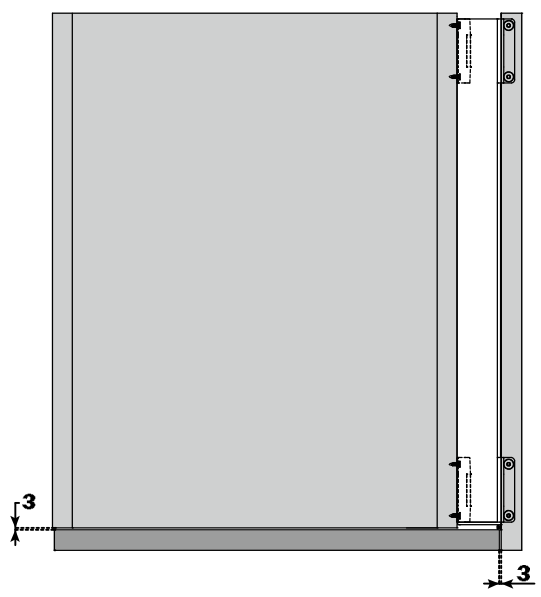
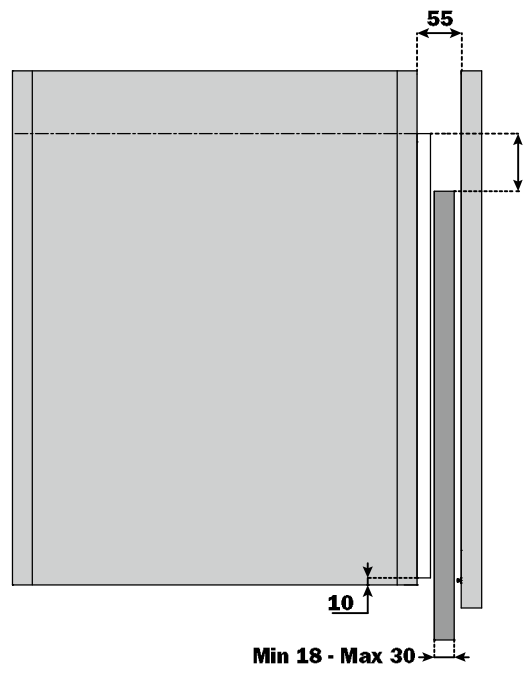

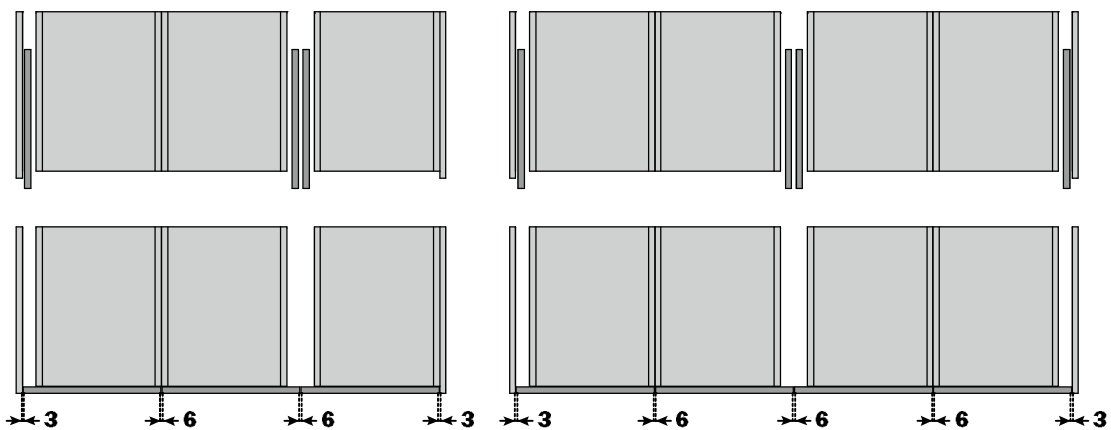
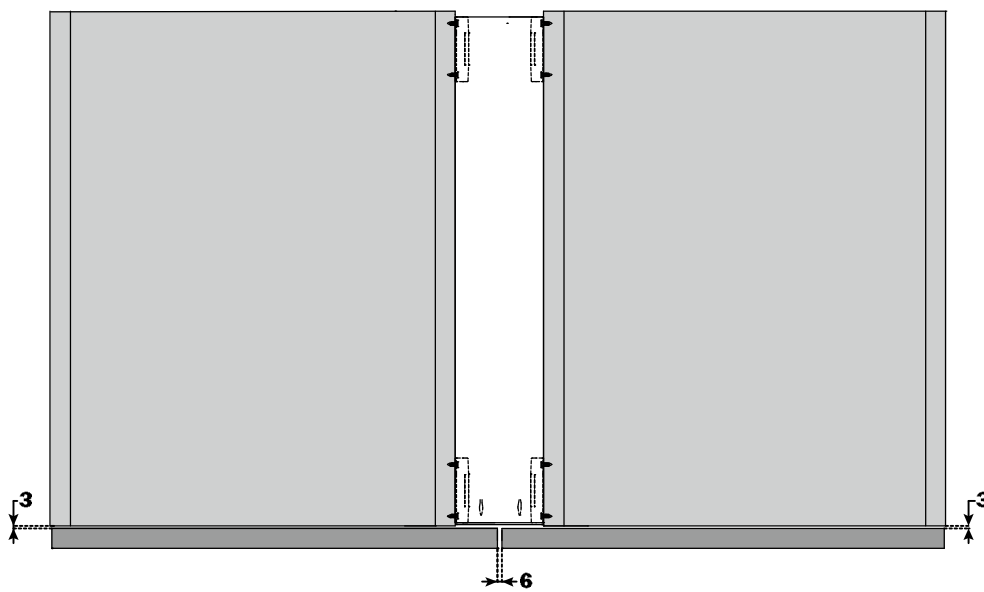
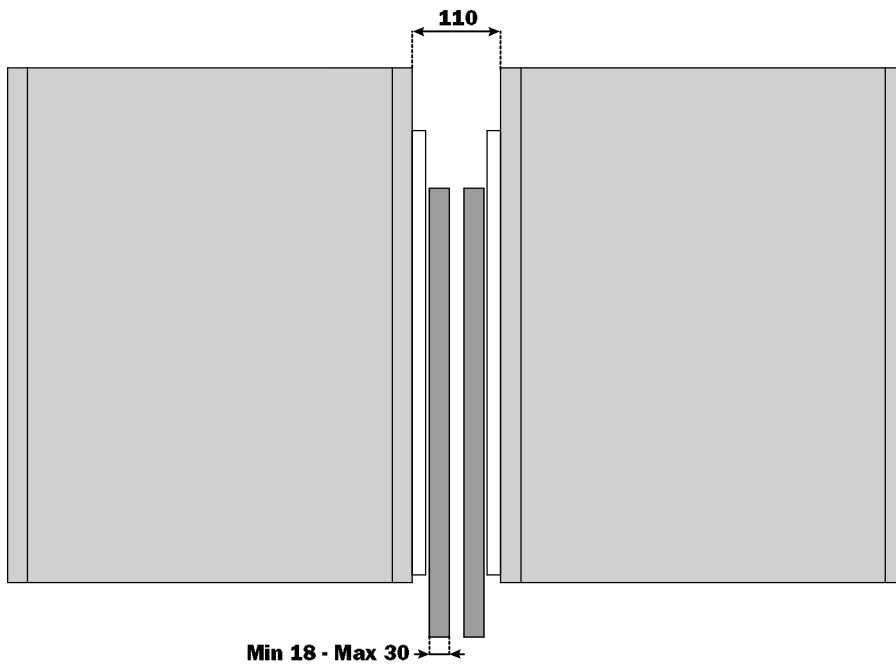

[ITA] **Calcolo del valore LPU**
Scelta della camma

[ENG] **Calculating the LPU value**
Selecting the cam connectors

[ESP] **Cálculo del valor LPU**
Elección de la leva (cam)

[DEU] **Berechnung Des Wertes LPU**
Auswahl Des Nocken (Cam)

[POR] **cálculo do valor LPU**
escolha do cam

[FRA] **Calcul de la valeur LPU**
Choix de la came

[ZH] **计算 LPU, 选择凸轮连接片**



LPS* = Profondità struttura
Cabinet depth
Schrantiefe
Profondeur de la structure
Structure Profondeur
Profundidade da estrutura
柜体深度

LPU** = Profondità struttura utile
Usable cabinet depth
Nutzbare Schranktiefe
Profundidad de estructura útil
Estructura de profundidad útil
Profundidade útil da estrutura
系统深度 (有效柜体深度)

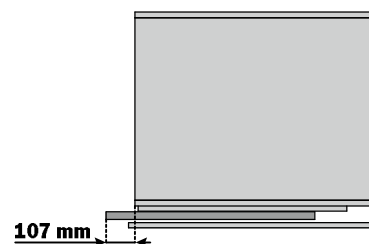
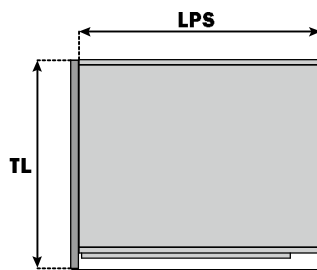
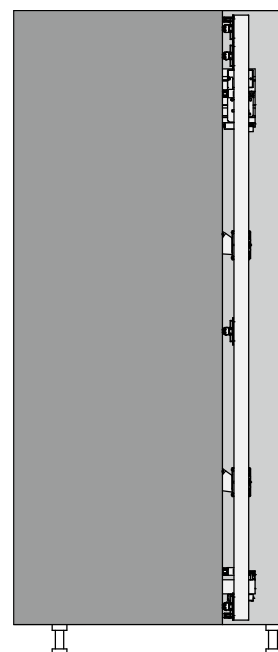
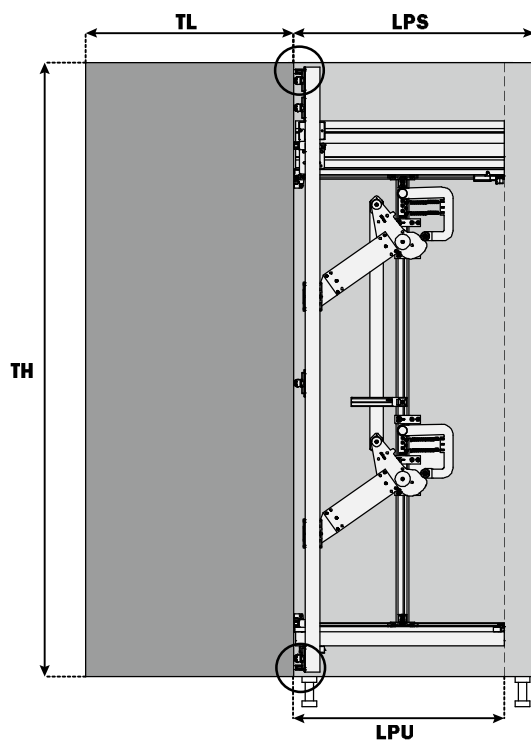
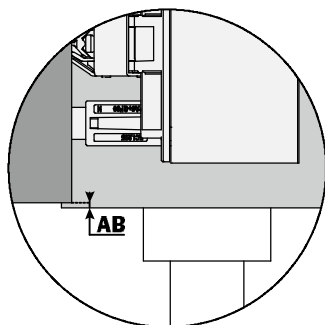
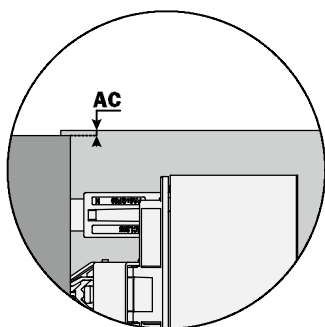

LPS < TL



LPU = LPS

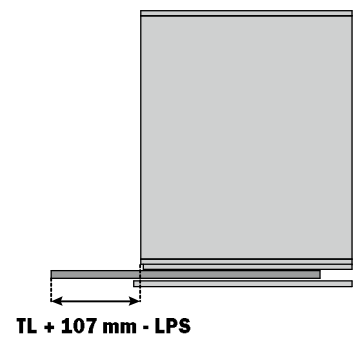
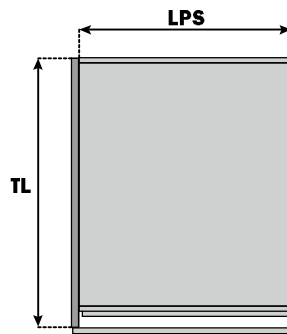
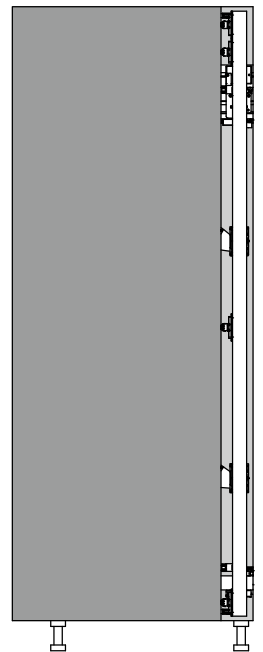
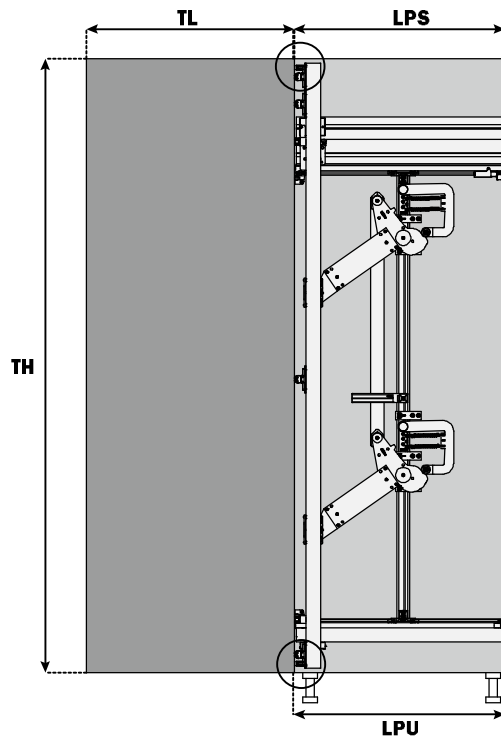
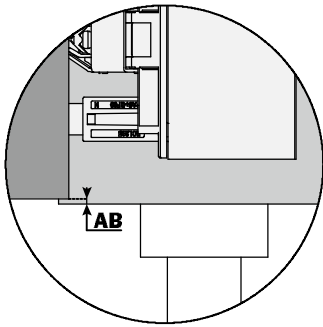
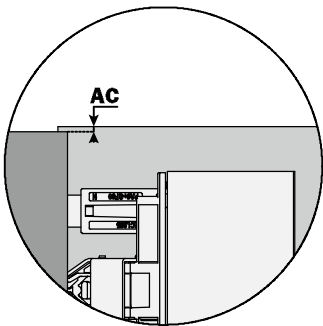

[ITA] **Calcolo della sporgenza con anta aperta**

[ENG] **Calculating the door protrusion from the cabinet**

[ESP] **Cálculo del saliente de la puerta con puerta abierta**

[DEU] **Berechnung Des Türvorsprungs Bei Geöffneter Tür**

[POR] **Cálculo do avanço com a porta aberta**

[FRA] **Calcul de la sortie de la porte avec la porte en position ouverte**

[ZH] **计算门板突出柜体的距离**

LPS ≥ TL

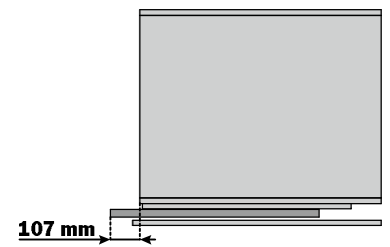
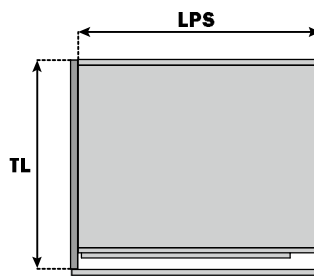
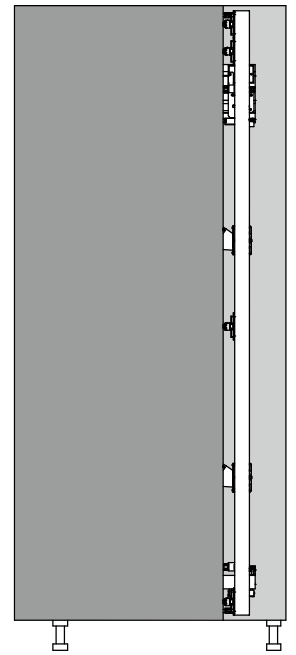
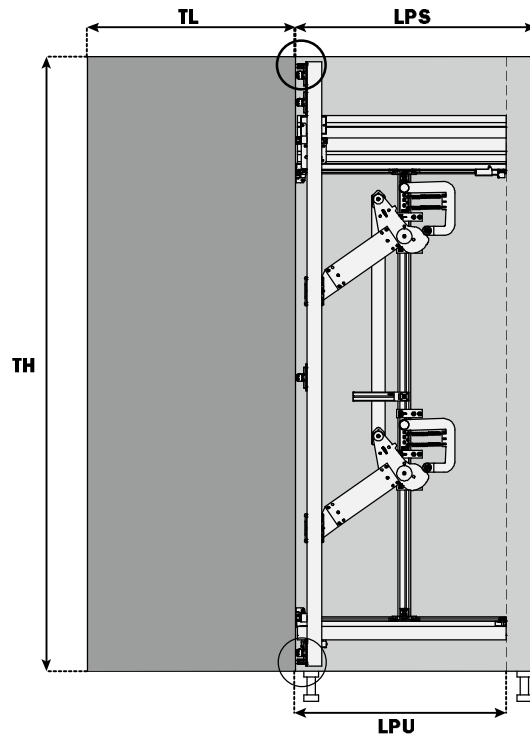
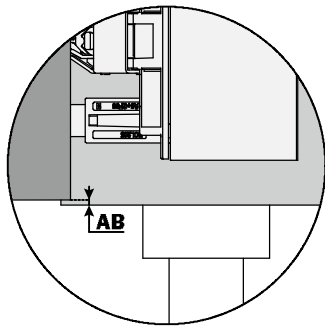
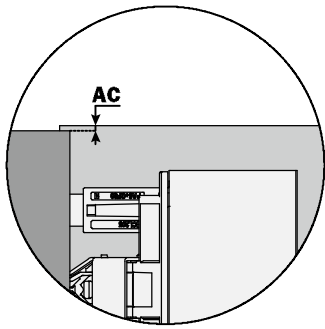

**ESEMPIO
EXAMPLE
BEISPIEL
EXEMPLE
EJEMPLO
EXEMPLO
示例**

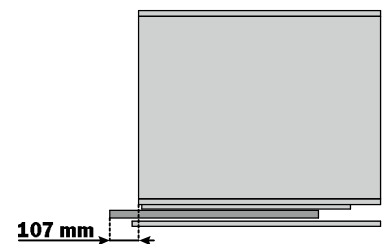
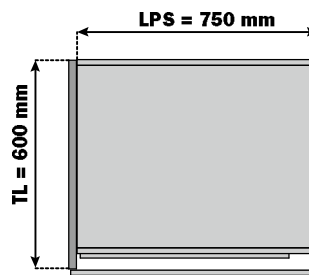

LPS ≥ TL

LPS < TL

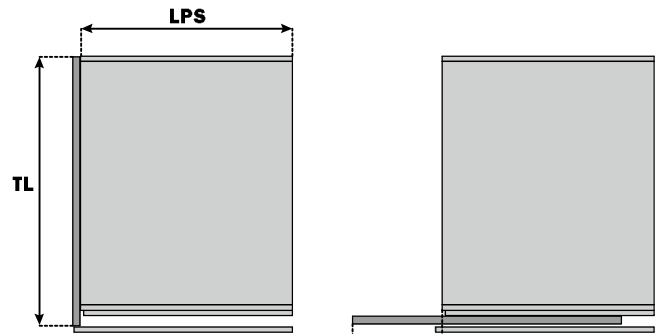
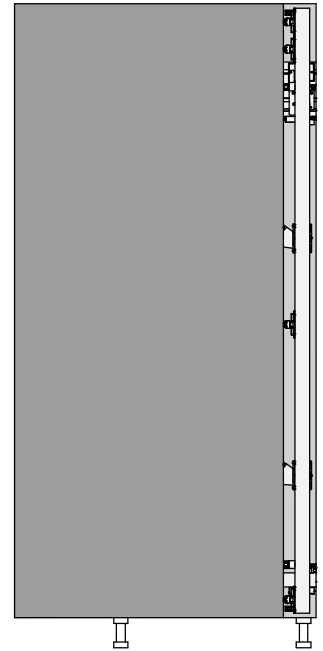
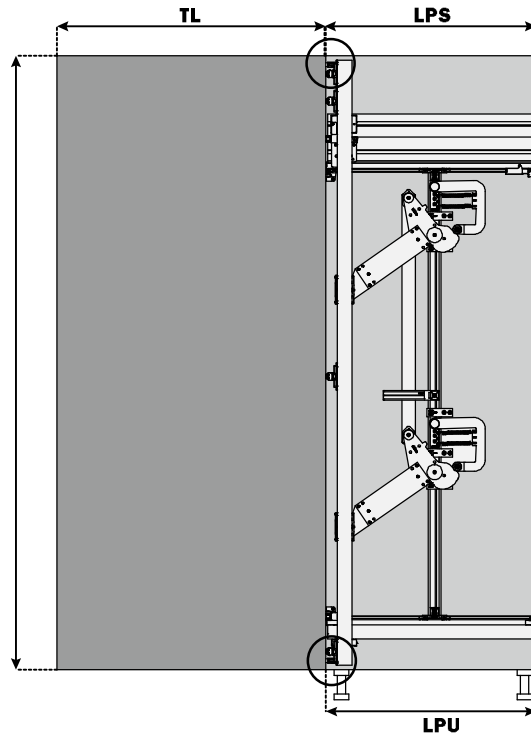
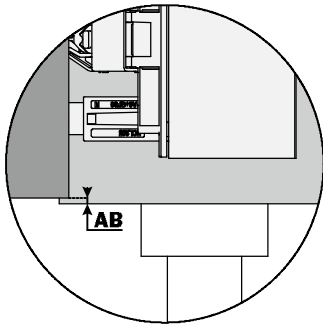
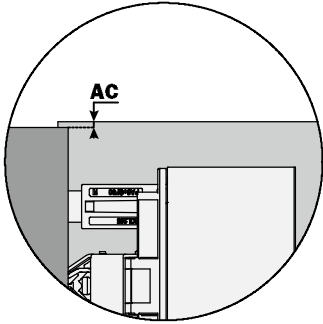

$TL + 107 \text{ mm} - LPS$

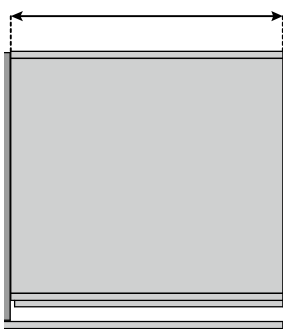

LPS = TL

107 mm

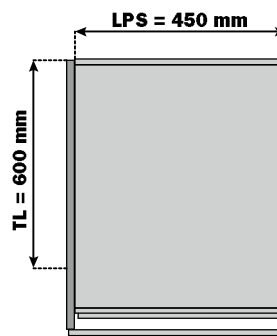
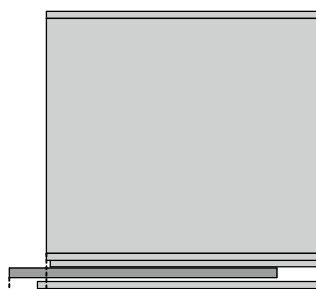

LPS < TL

$600 + 107 - 450 = 257 \text{ mm}$

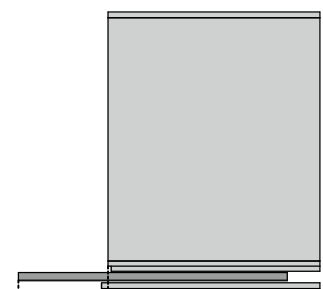

-
- Meccanismo parzialmente assemblato
 - Partially assembled mechanism
 - Teilmontierter Mechanismus
 - Mécanisme partiellement assemblé
 - Mecanismo parcialmente ensamblado
 - Mecanismo parcialmente montado
 - 部分预装版本

[ITA] **Contenuto imballi**

Meccanismo parzialmente assemblato

- 1930 - 2230 mm: 4 cerniere (max 24 Kg)
- 2231 - 2500 mm: 4 cerniere (max 30 Kg)

[ENG] **Pack contents**

Partially assembled mechanism

- 1930 - 2230 mm: 4 hinges (max 24 Kg)
- 2231 - 2500 mm: 4 hinges (max 30 Kg)

[ESP] **Relación contenido embalaje**

meccanismo parzialmente ensamblado

- 1930 - 2230 mm: 4 bisagras (max 24 Kg)
- 2231 - 2500 mm: 4 bisagras (max 30 Kg)

[DEU] **Verpackungsinhalt**

Teilmontierter Mechanismus

- 1930 - 2230 mm: 4 Scharniere (max 24 Kg)
- 2231 - 2500 mm: 4 Scharniere (max 30 Kg)

[POR] **Conteúdo das embalagens do**

meccanismo parzialmente montado

- 1930 - 2230 mm: 4 dobradiça (max 24 Kg)
- 2231 - 2500 mm: 4 dobradiça (max 30 Kg)

[FRA] **Contenu des emballages**

Mecanisme partiellement assemble

- 1930 - 2230 mm : 4 charnière (max 24 Kg)
- 2231 - 2500 mm : 4 charnière (max 30 Kg)

[ZH] **包装组件**

部分预装版本

- 1930 - 2230 mm: 4 hinges (max 24 Kg)
- 2231 - 2500 mm: 4 hinges (max 30 Kg)

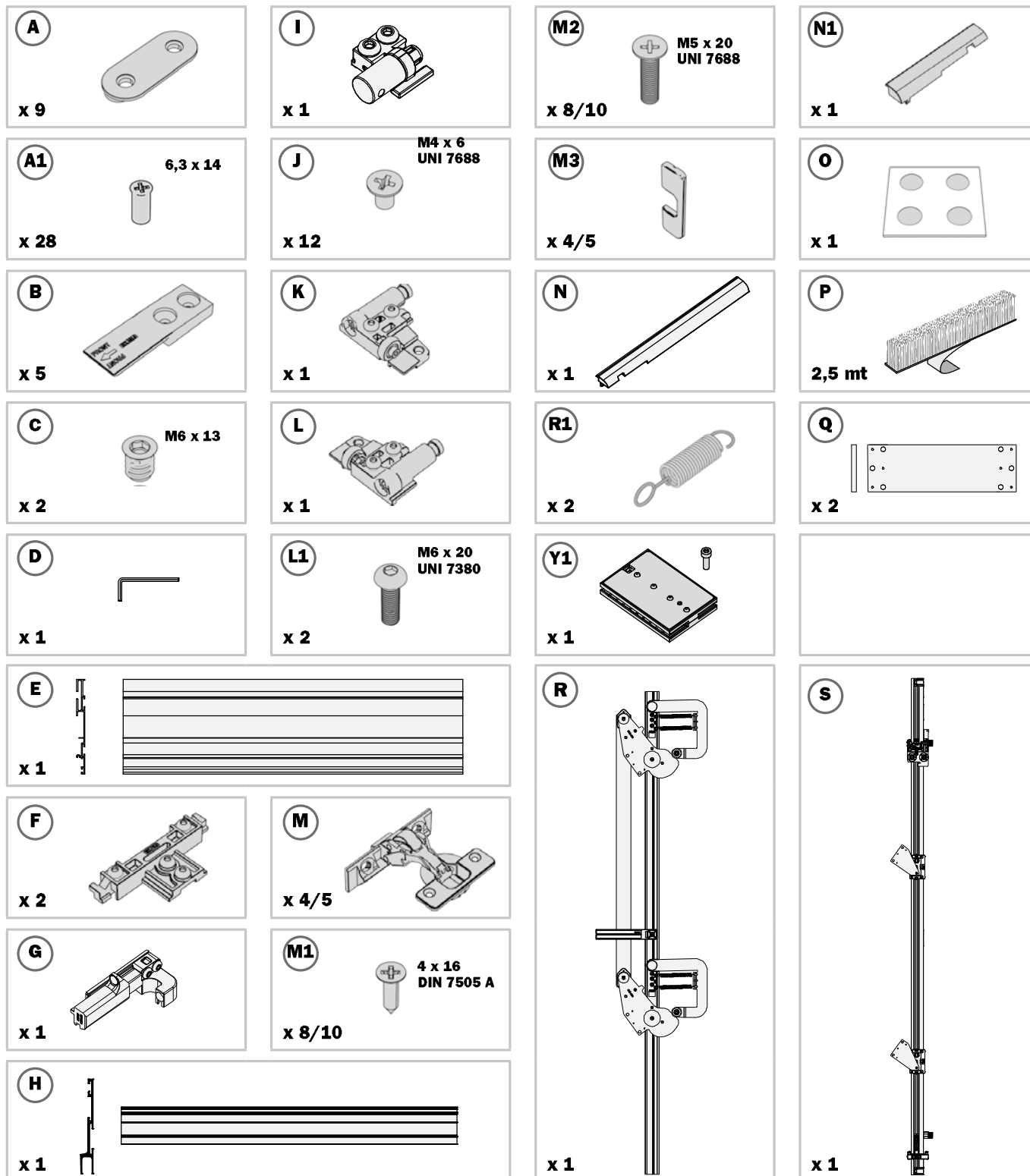

[ITA] **montaggio del meccanismo**

[ENG] **Assembly of the mechanism**

[ESP] **Montaje del mecanismo**

[DEU] **Montage Des Mechanismus**

[POR] **Montagem do mecanismo**

[FRA] **Montage du mecanisme**

[ZH] **组装系统机构**

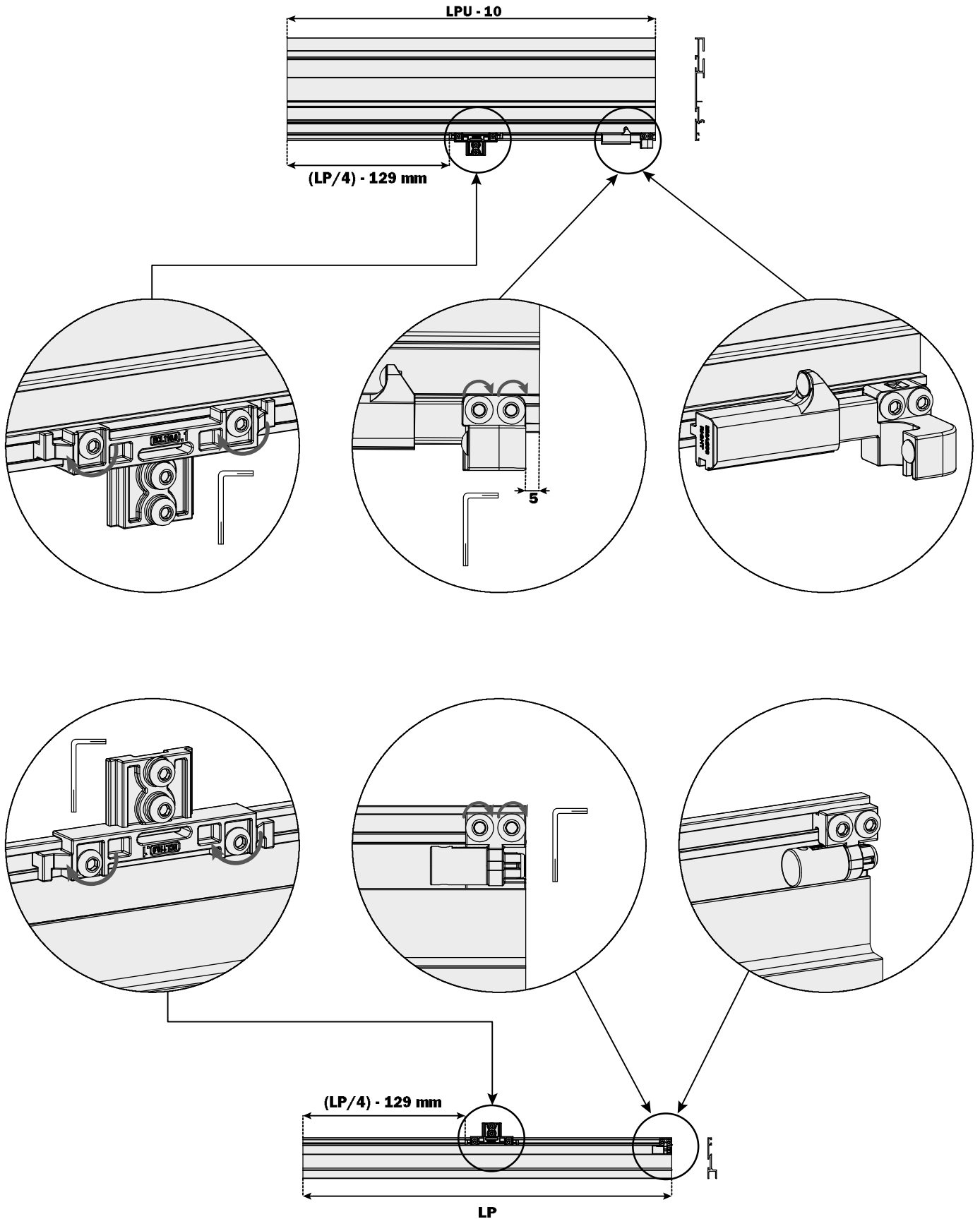

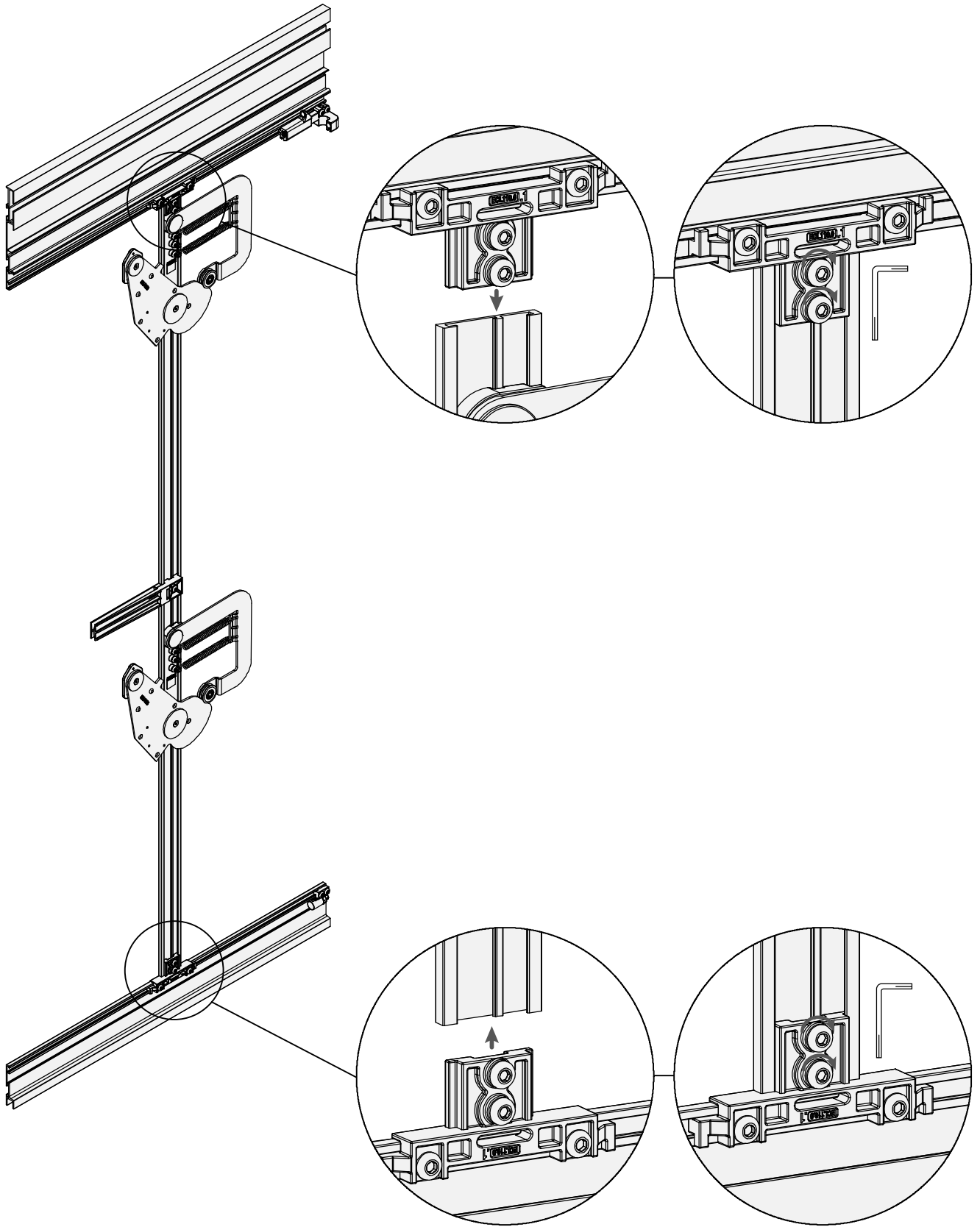

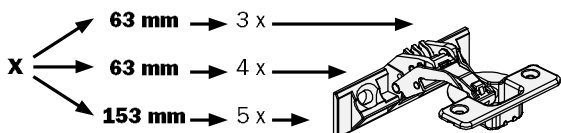
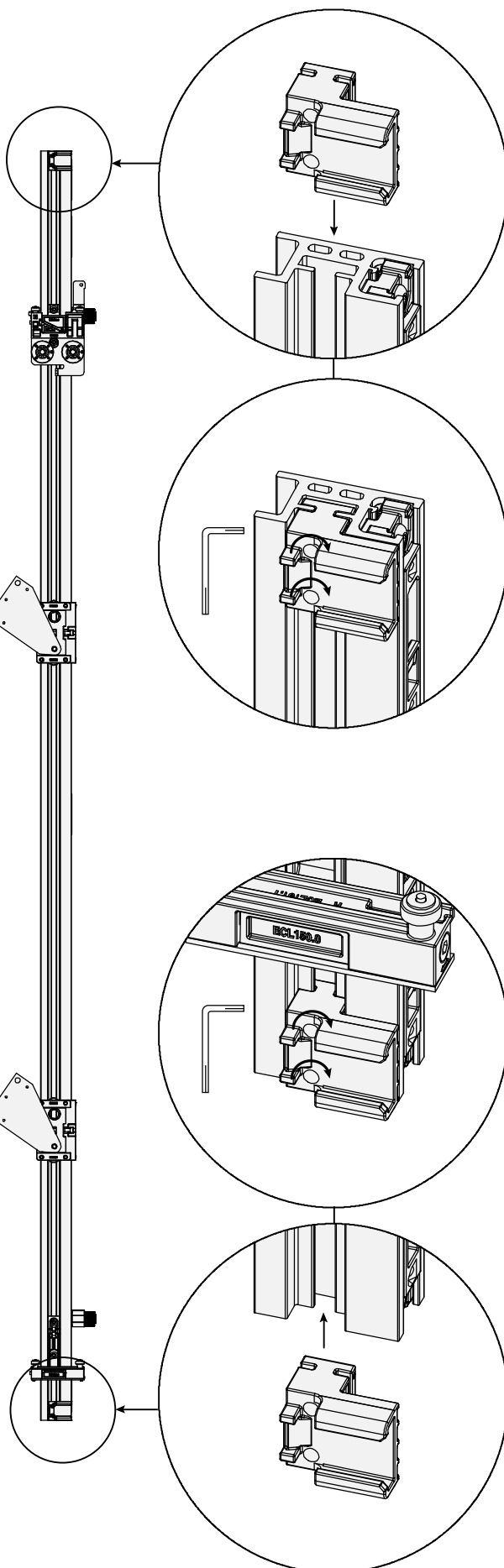
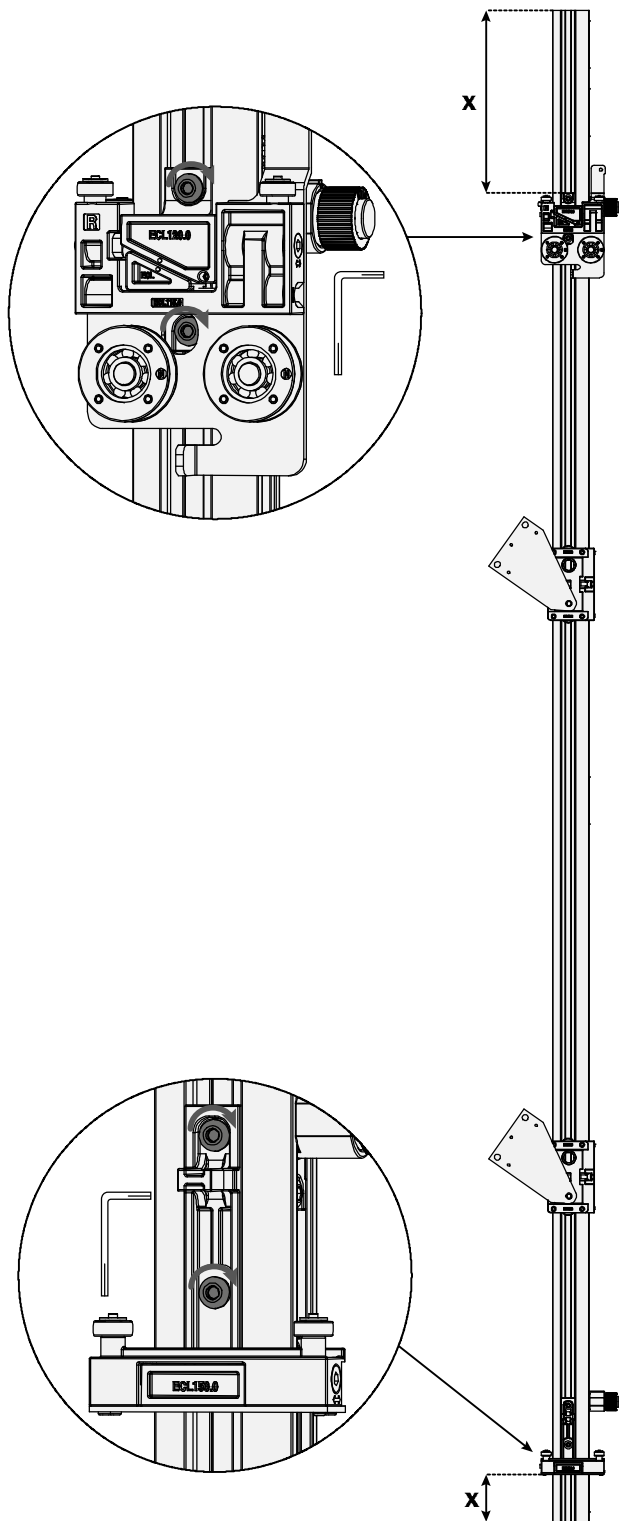
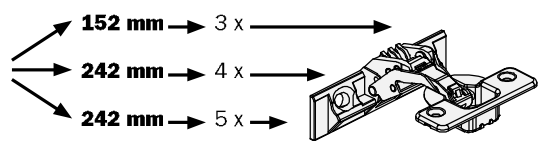

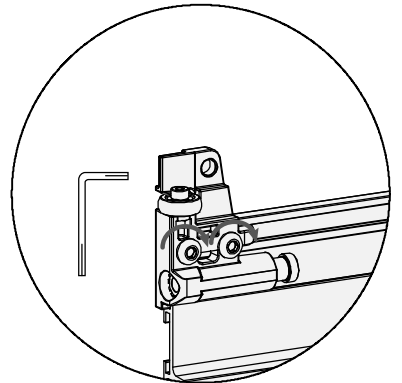
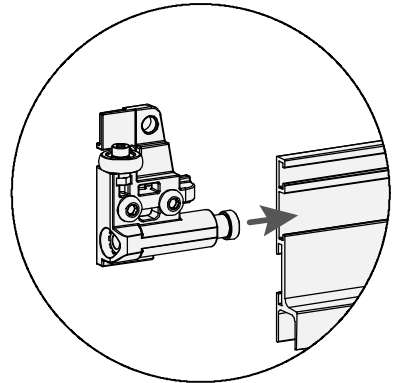
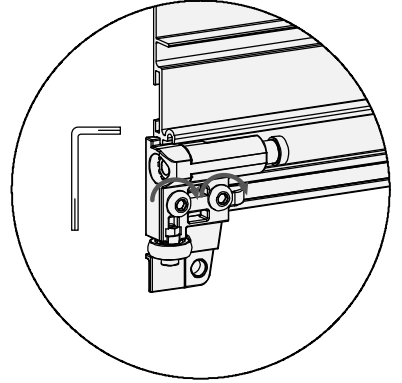
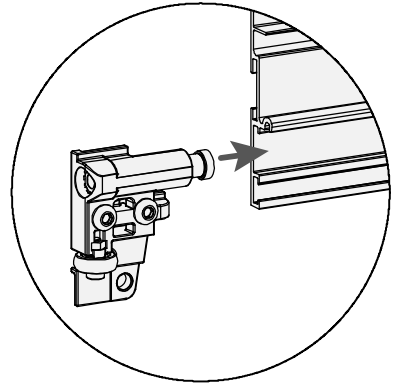
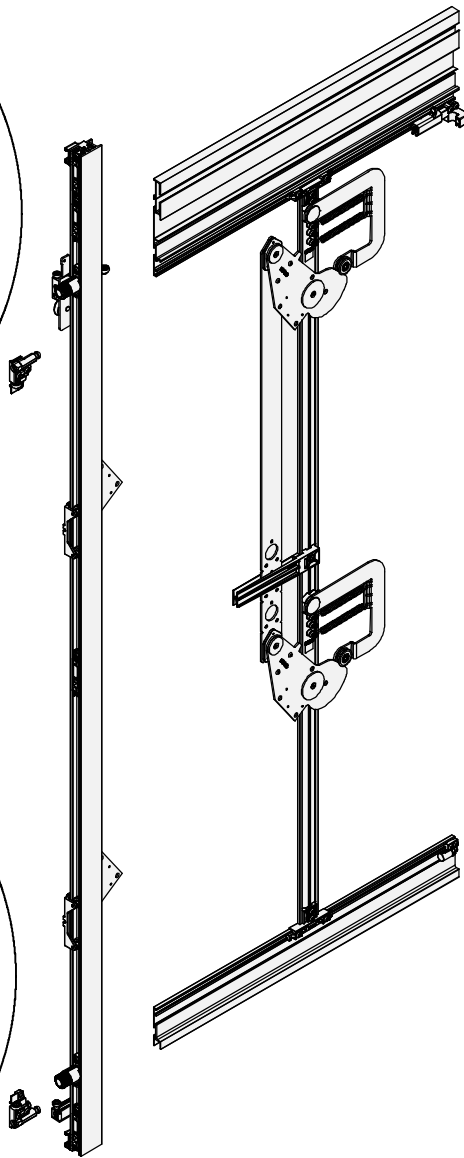
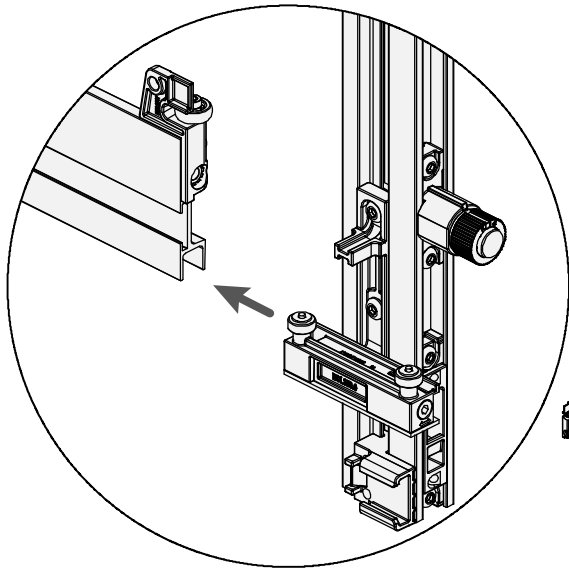
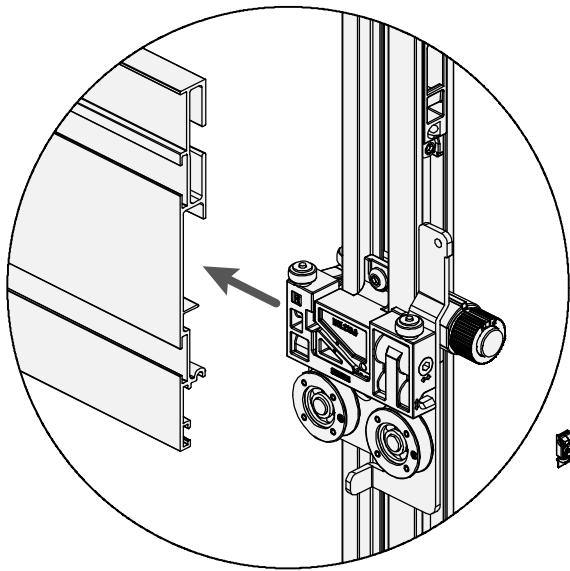

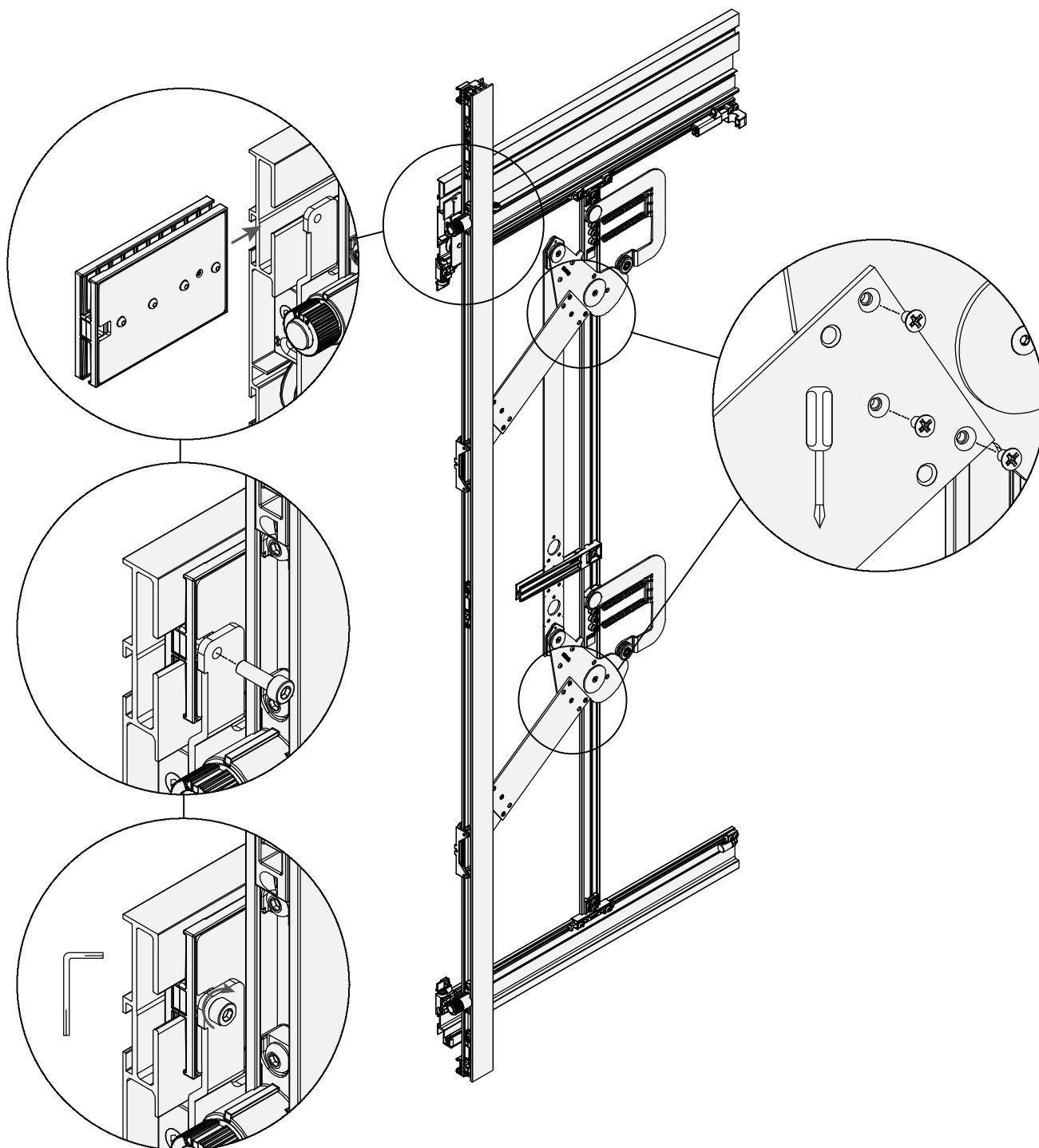

[ITA] Lavorazioni sull'anta

[ENG] Door drillings

[ESP] Mecanizados en la puerta

[DEU] Bearbeitungen der Tür

[POR] Usinagens na porta

[FRA] Opérations sur la porte

[ZH] 门板孔位

TH 1930 - 2230 mm



TH 1956 - 2256 mm

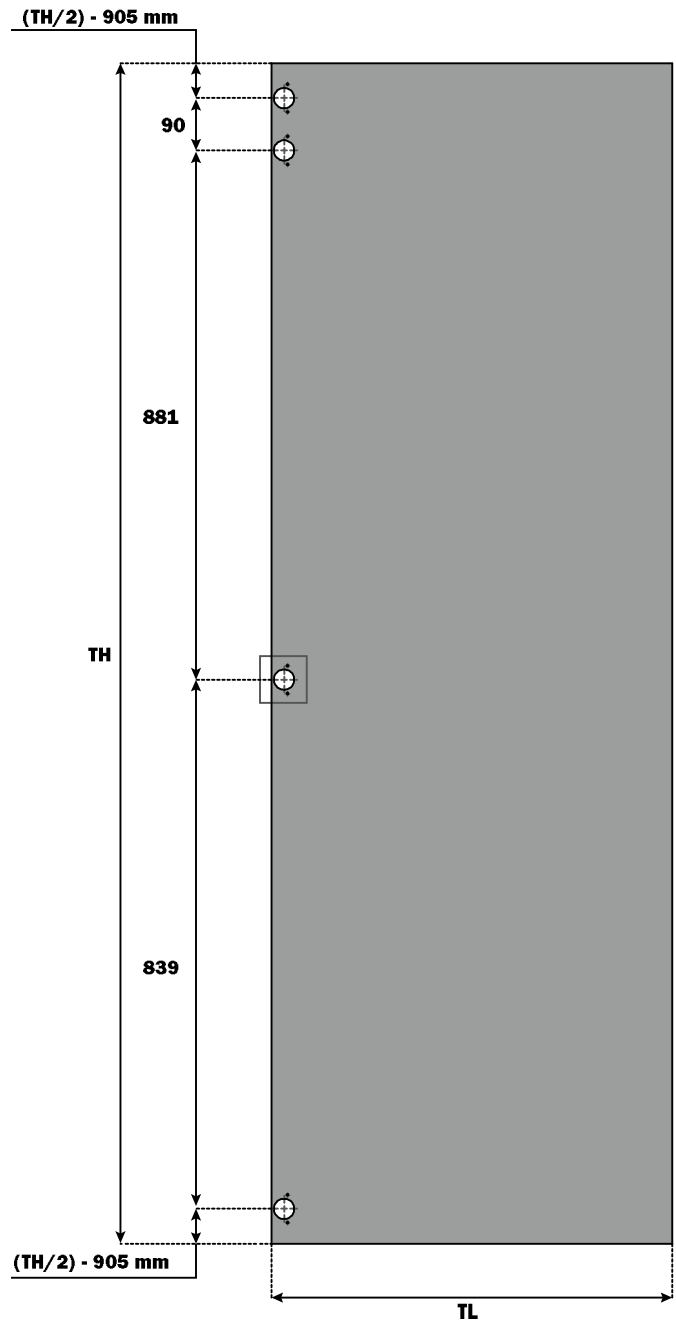
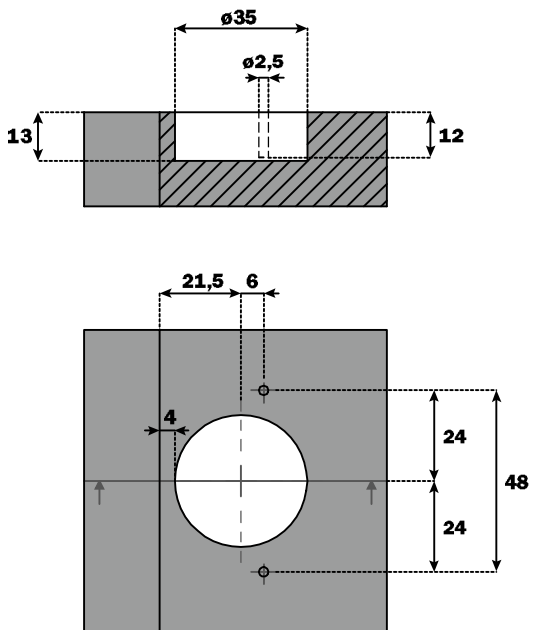
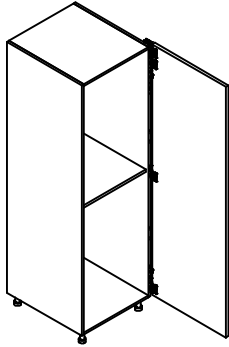

T max = 30 mm

[ITA] Lavorazioni sull'anta

[ENG] Door drillings

[ESP] Mecanizados en la puerta

[DEU] Bearbeitungen der Tür

[POR] Usinagens na porta

[FRA] Opérations sur la porte

[ZH] 门板孔位

TH 2230-2500 mm



TH 2256 - 2500 mm

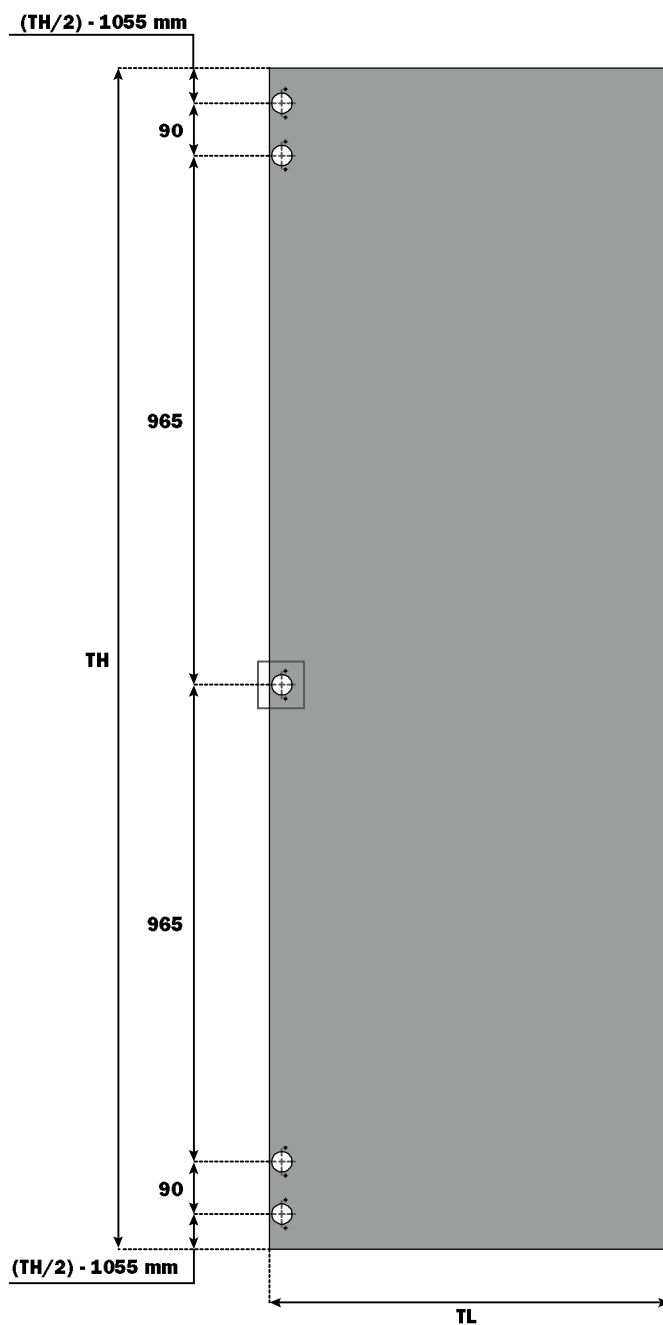
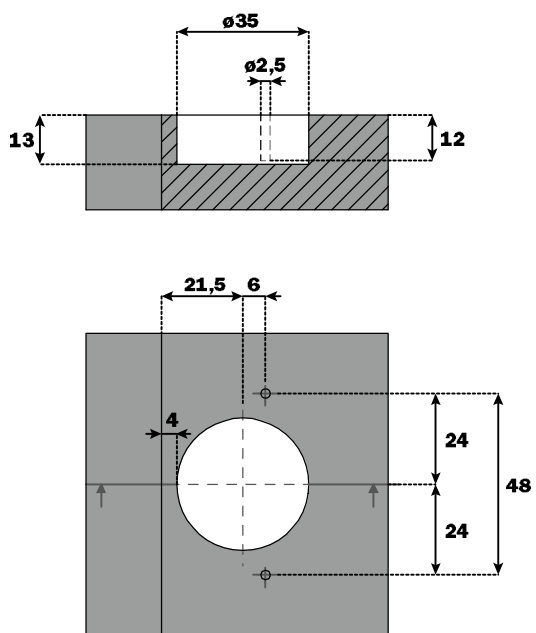

[ITA] Lavorazioni sul fianco

[ENG] Side panel drillings

[ESP] Mecanizados en el lateral

[DEU] Bearbeitungen der Seite

[POR] Usinagens na lateral

[FRA] Opérations sur le côté

[ZH] 侧板孔位

TH 1930 • 2230 mm



TH 1956 - 2256

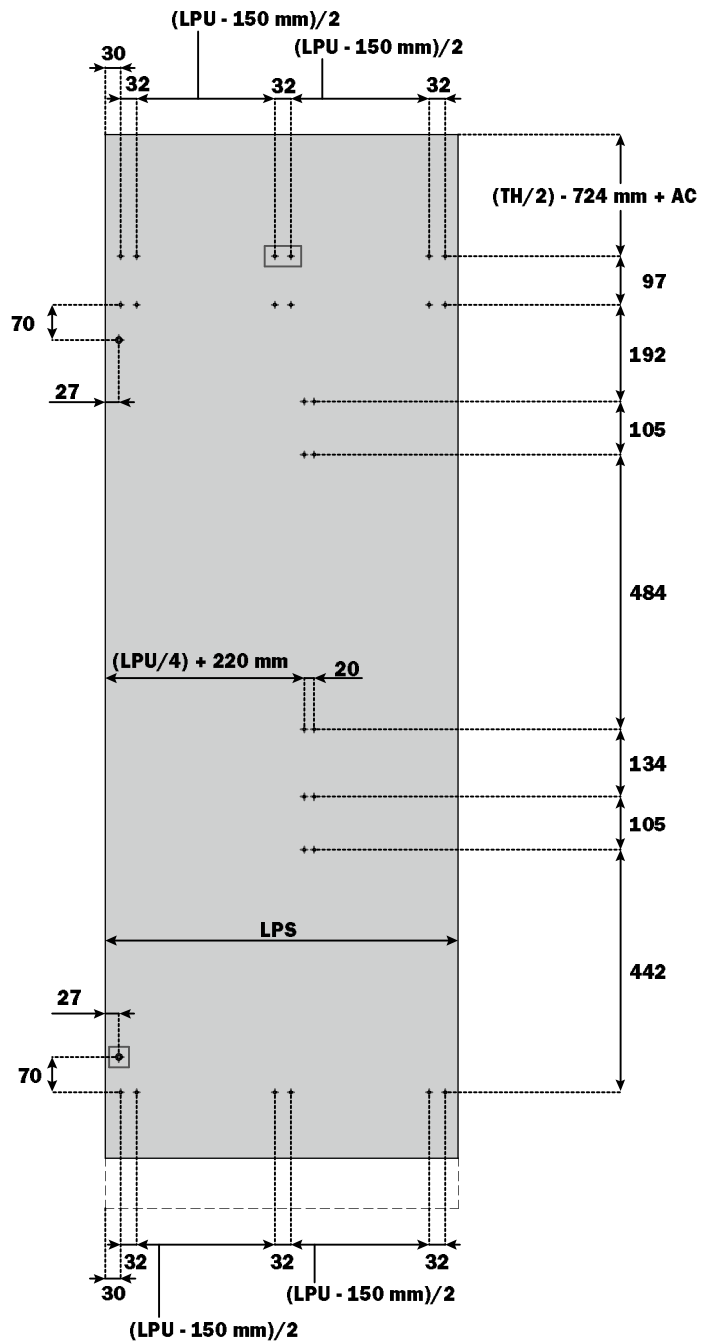
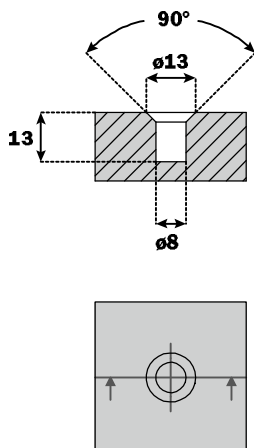
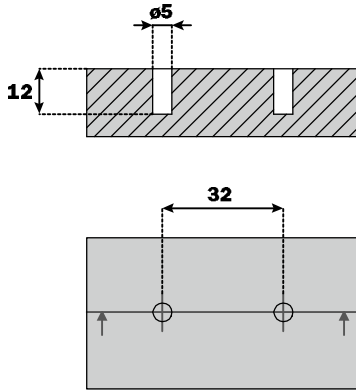
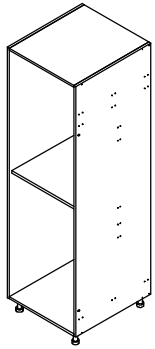

[ITA] Lavorazioni sul fianco

[ENG] Side panel drillings

[ESP] Mecanizados en el lateral

[DEU] Bearbeitungen der Seite

[POR] Usinagens na lateral

[FRA] Opérations sur le côté

[ZH] 侧板孔位

TH 2230-2500 mm



TH 2256 - 2500 mm

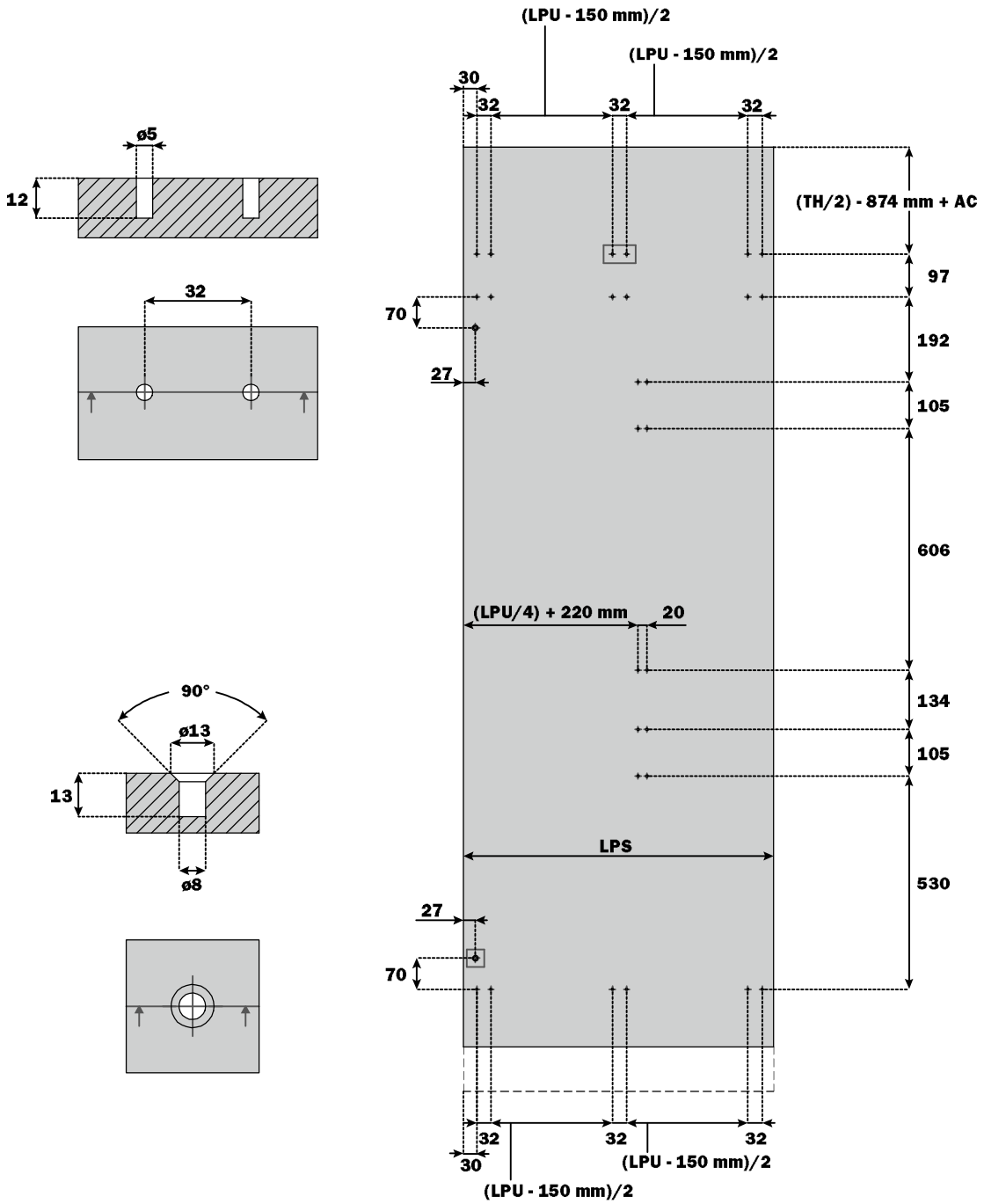

-
- Montaggio del meccanismo sul mobile
 - Fitting the mechanism to the cabinet
 - Montage des Mechanismus am Möbel
 - Montage du mécanisme sur le meuble
 - Montaje del mecanismo en el mueble
 - Montagem do mecanismo no móvel
 - 系统机构安装至柜体

[ITA] Applicazione delle clip

[ENG] Fixing the clips

[ESP] Aplicación de los clips

[DEU] Befestigung der clips

[POR] Aplicação dos cliques

[FRA] Installation des clips

[ZH] 固定卡扣

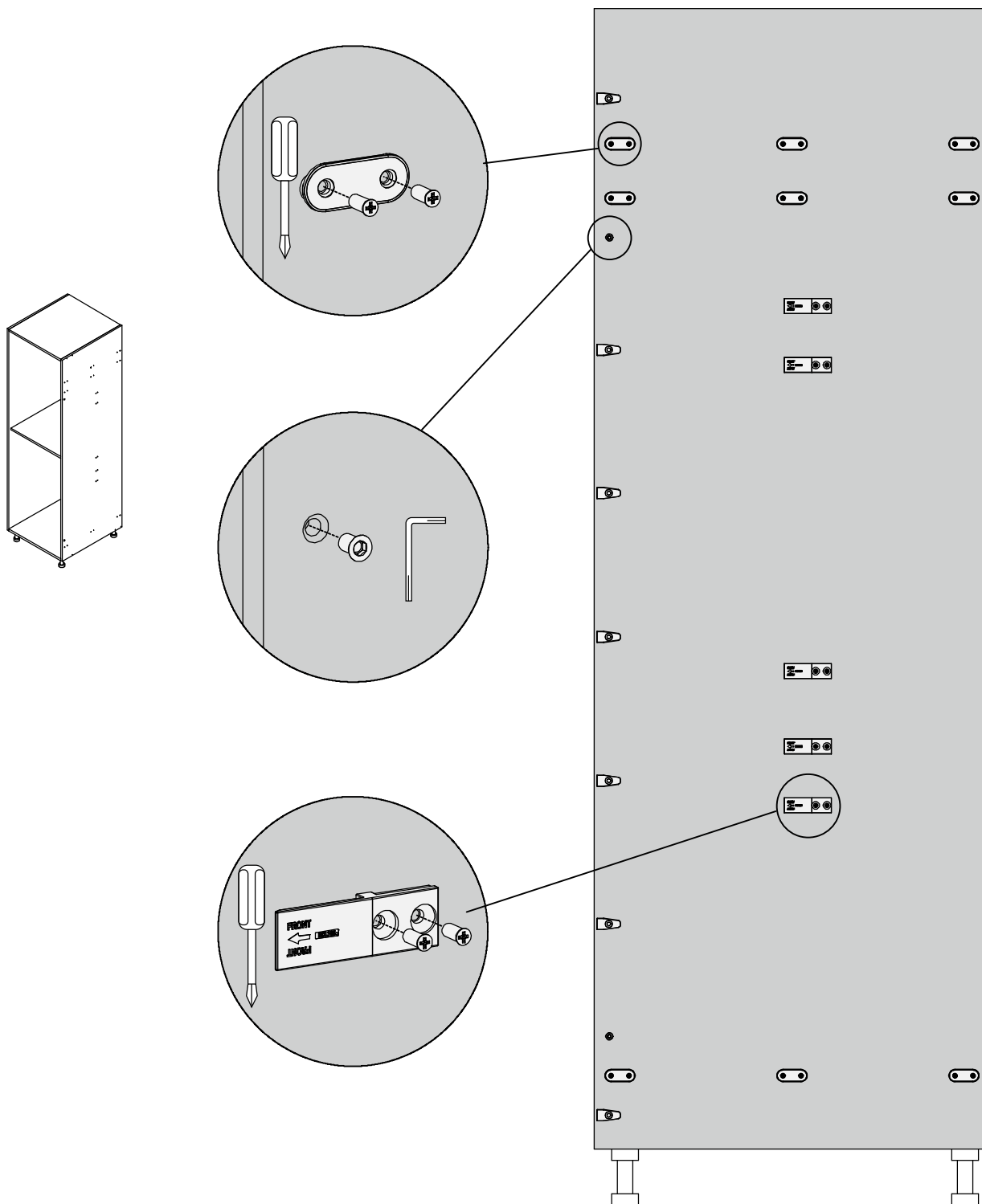

[ITA] **Montaggio del meccanismo sul mobile**

[ENG] **Fitting the mechanism to the cabinet**

[ESP] **Montaje del mecanismo en el mueble**

[DEU] **Montage des Mechanismus am Möbel**

[POR] **Montagem do mecanismo no móvel**

[FRA] **Montage du mécanisme sur le meuble**

[ZH] **系统机构安装至柜体**

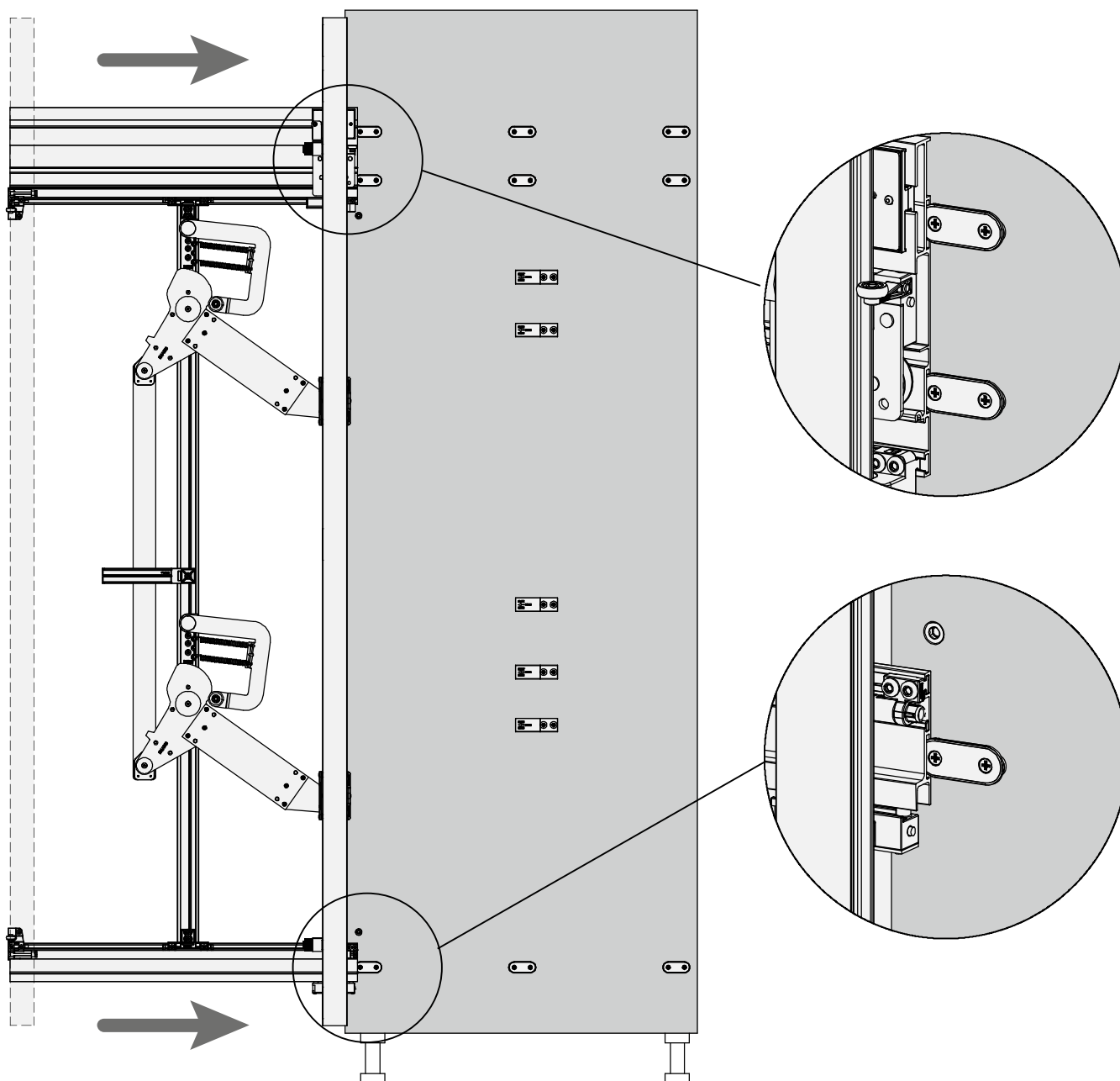

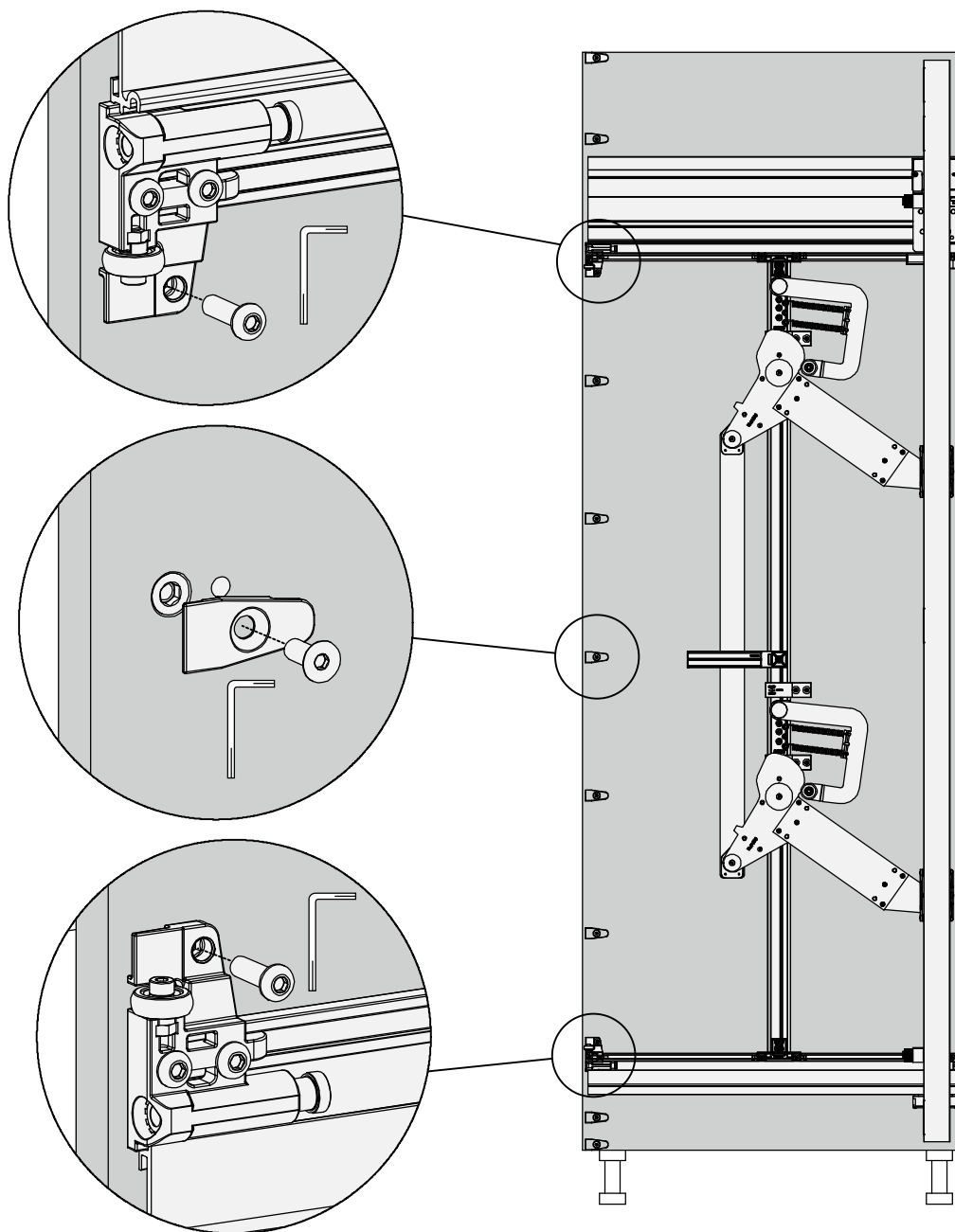

Exedra - Euro 32

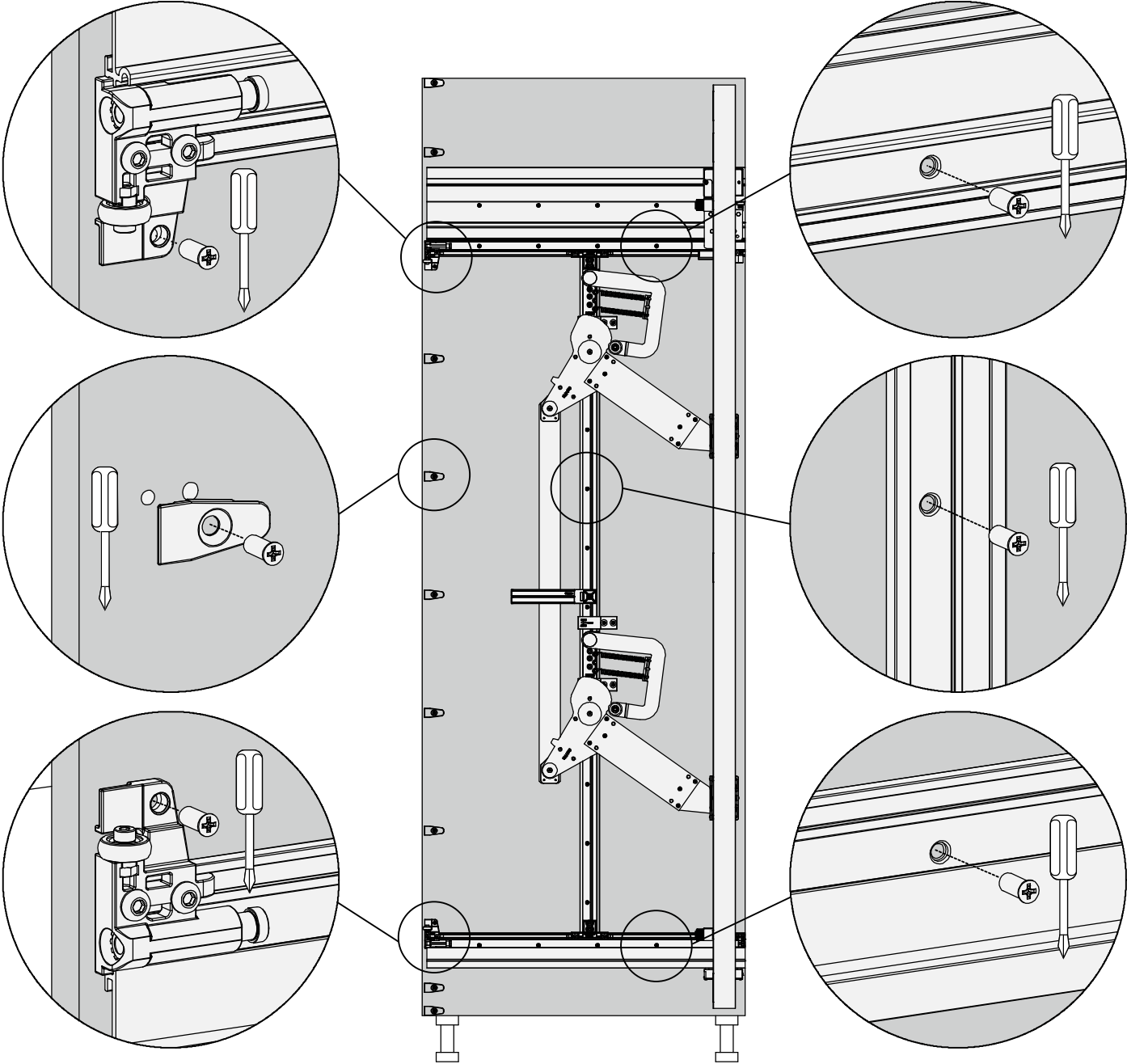

[ITA] **Preparazione e montaggio dell'anta**

[ENG] **Fitting the door onto the mechanism**

[ESP] **Preparación y montaje de la puerta**

[DEU] **Vorbereitung und Montage der Tür**

[POR] **Preparação e montagem da porta**

[FRA] **Opérations sur la porte et montage**

[ZH] 门板安装至系统机构

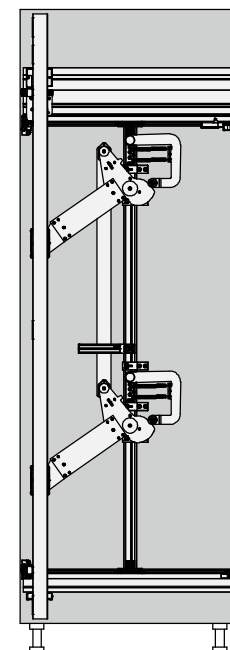
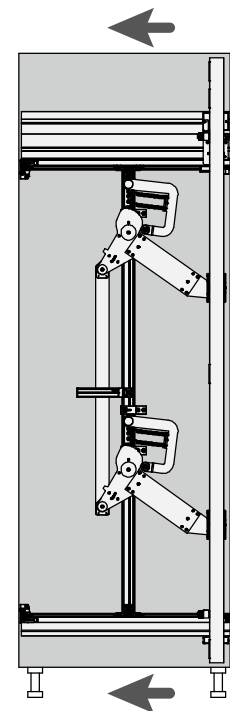
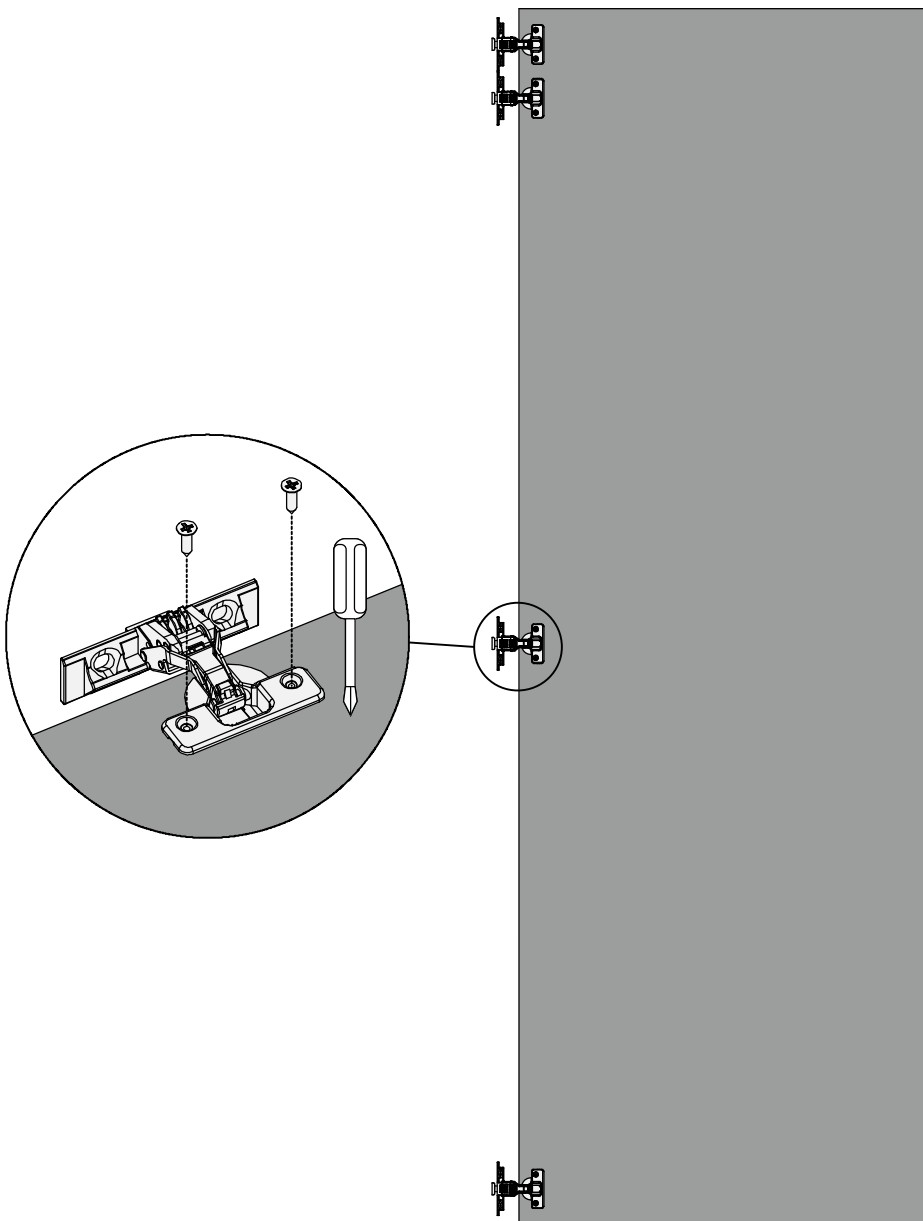

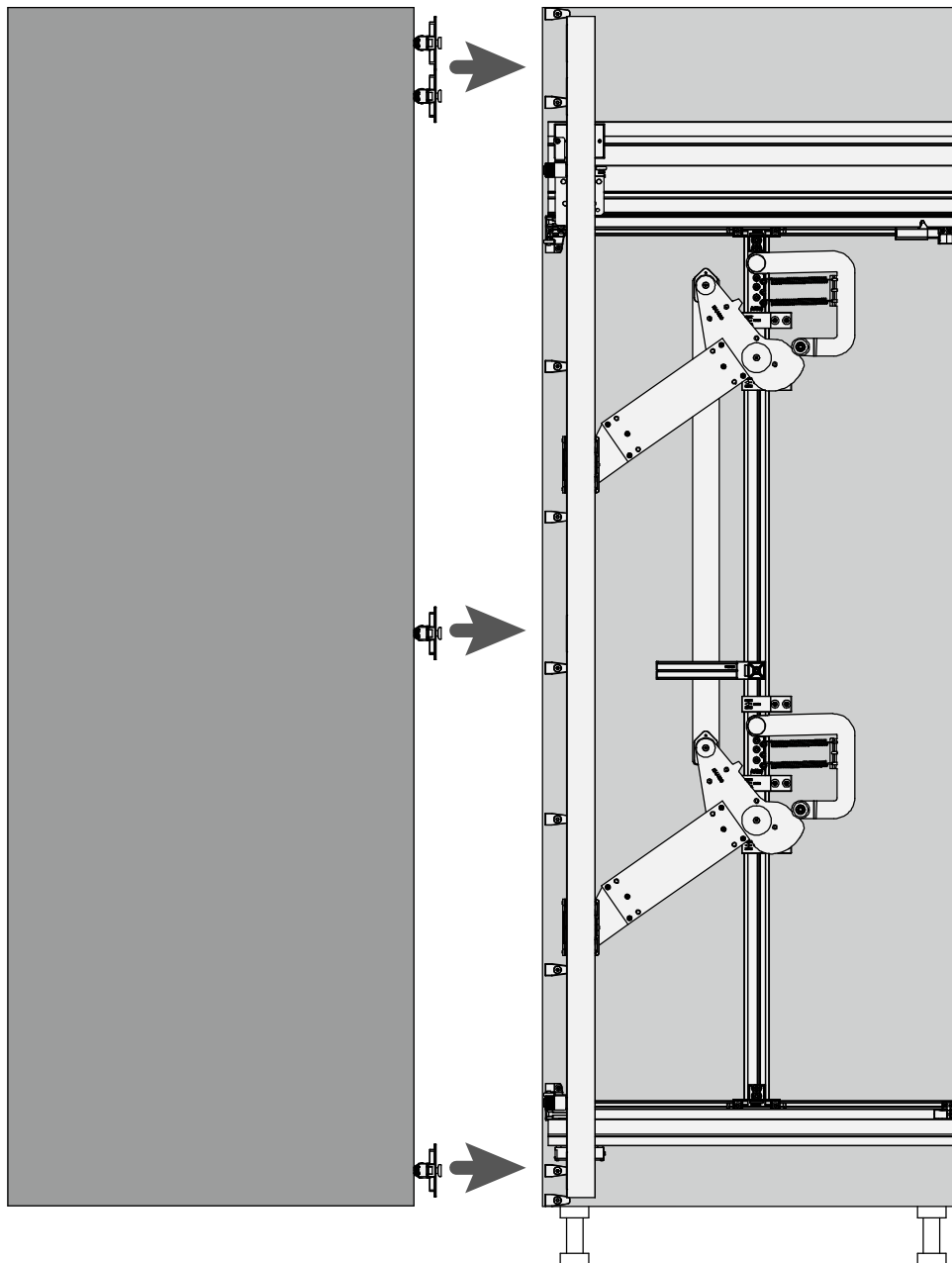
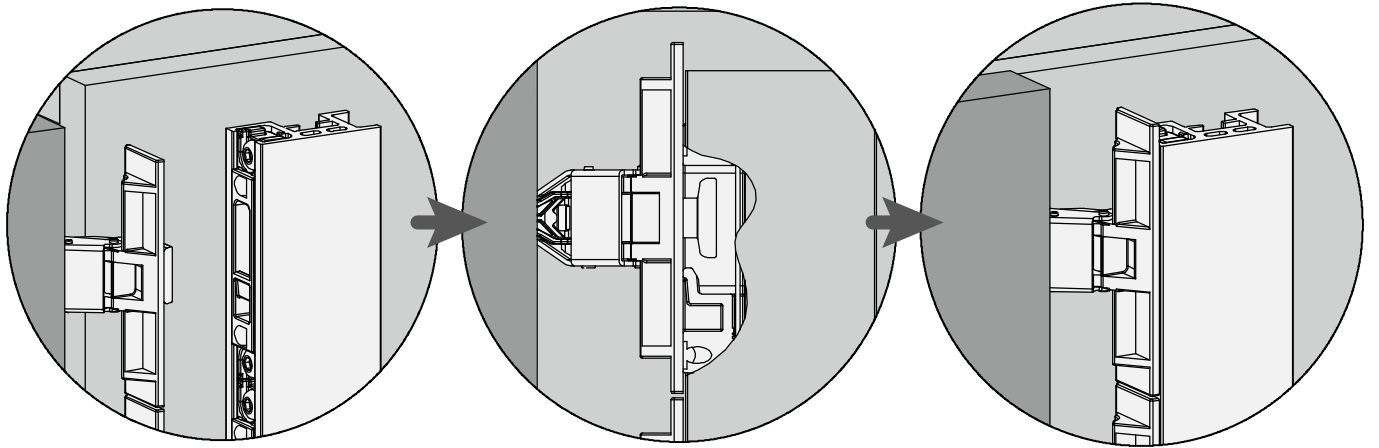

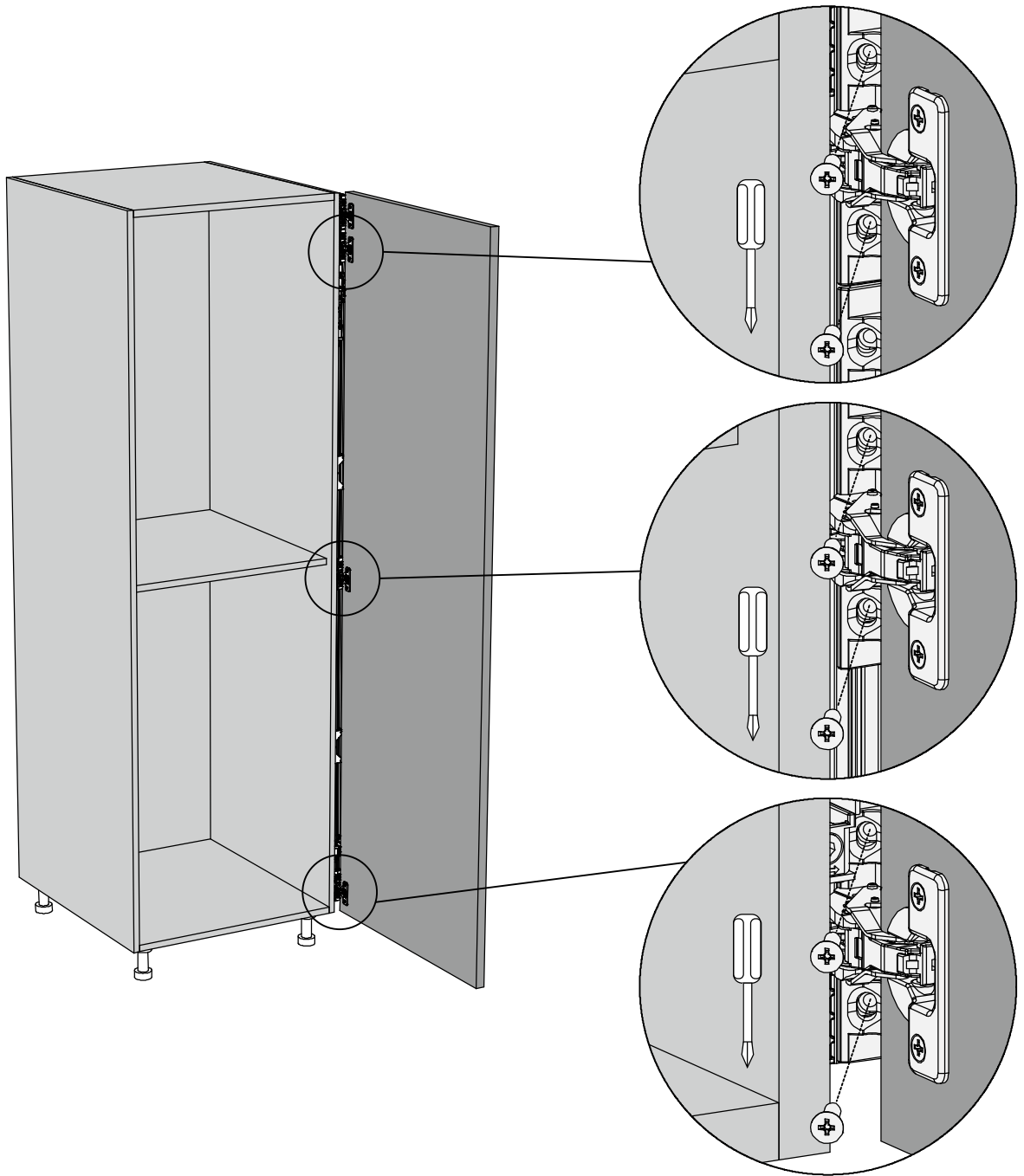

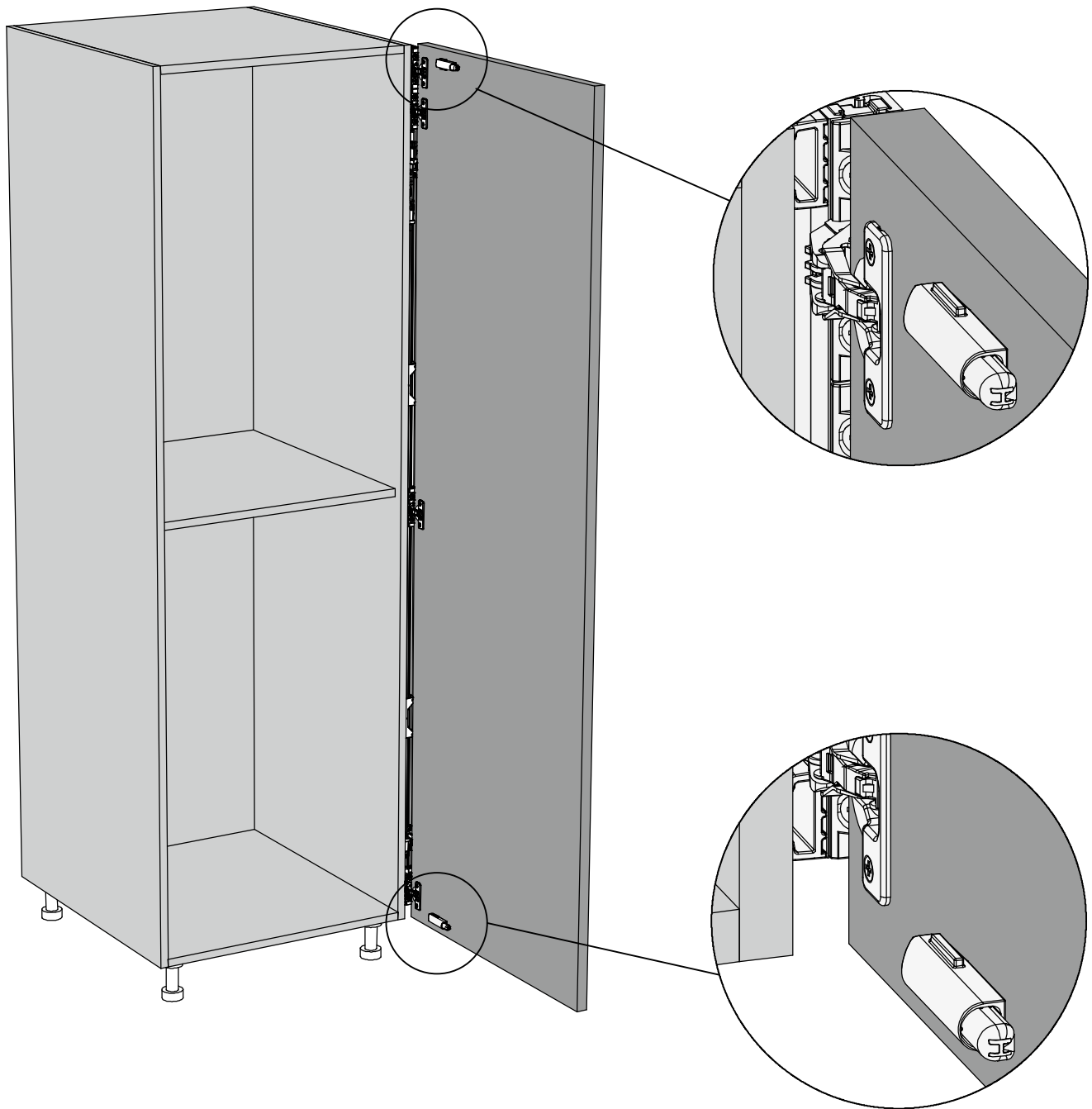

[ITA] **Regolazioni dell'anta**

[ENG] **Adjustment of the door**

[ESP] **Regulaciones de la puerta**

[DEU] **Verstellung der Tür**

[POR] **Regulagens da porta**

[FRA] **Réglage de la porte**

[ZH] 门板调节

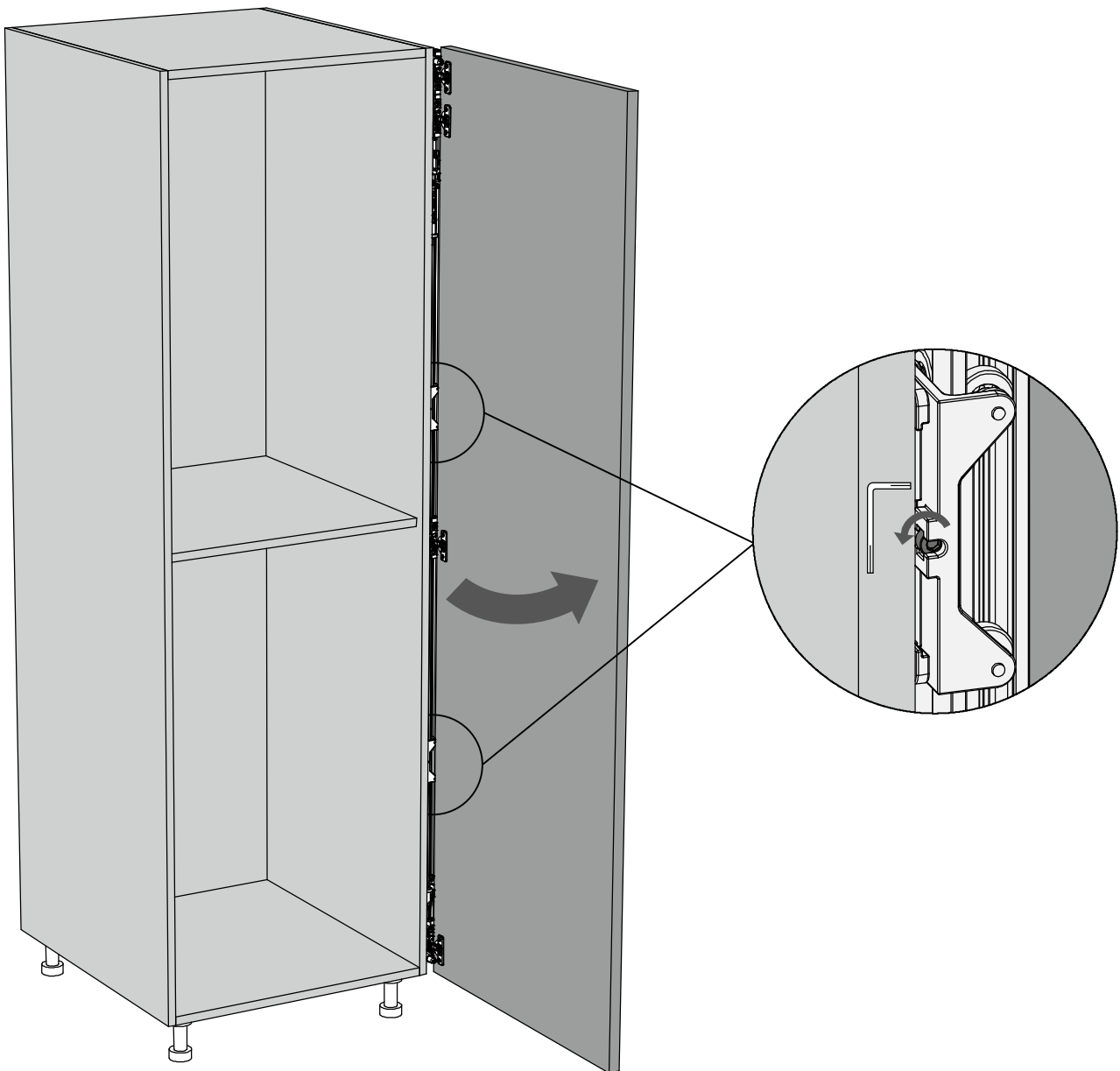

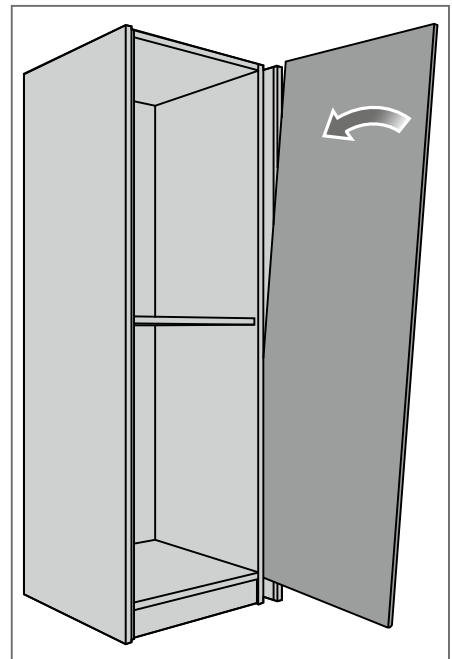
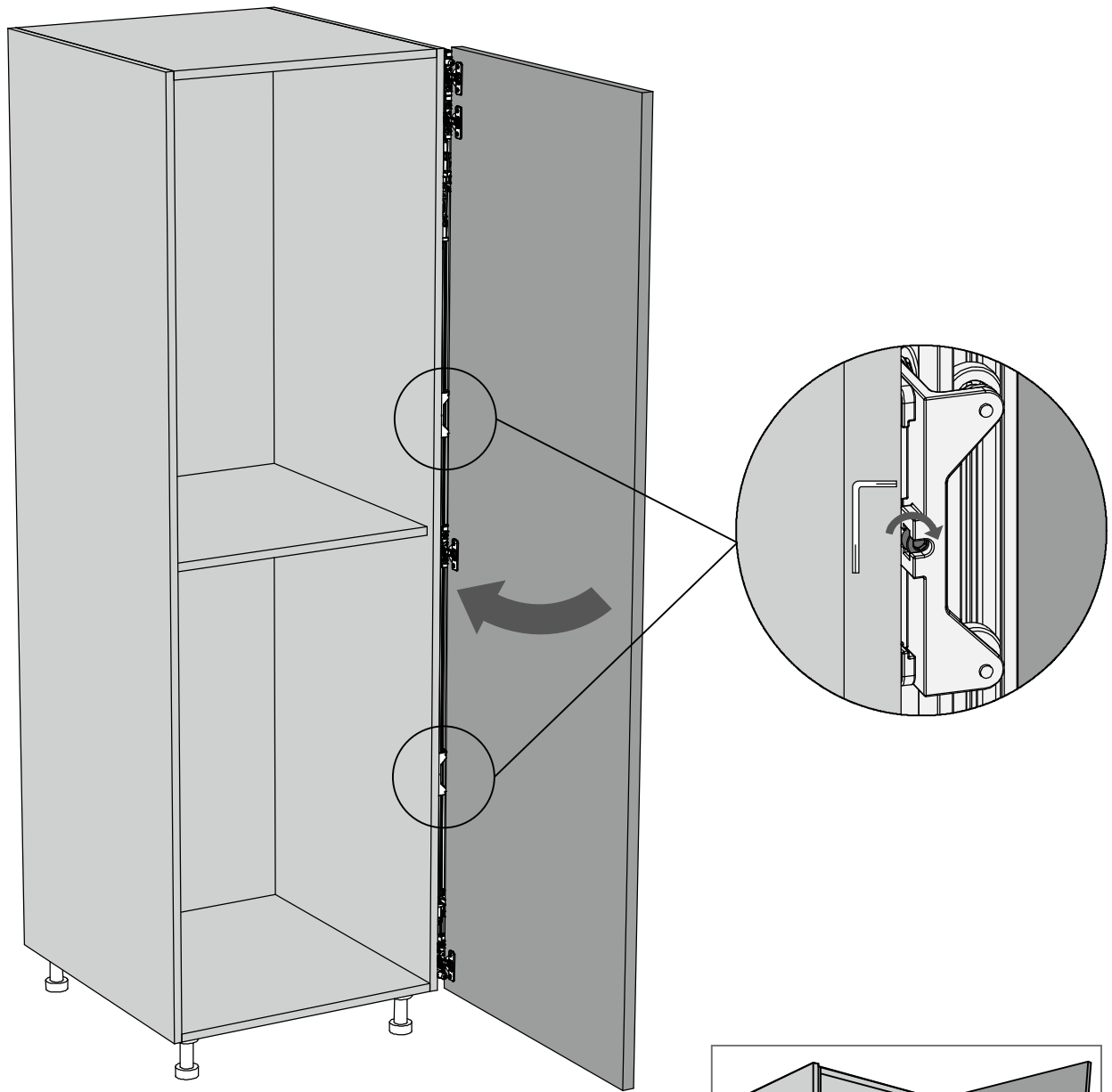

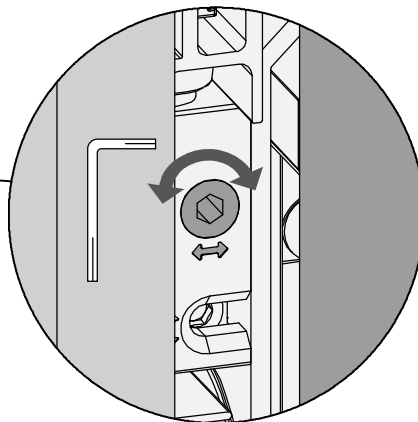
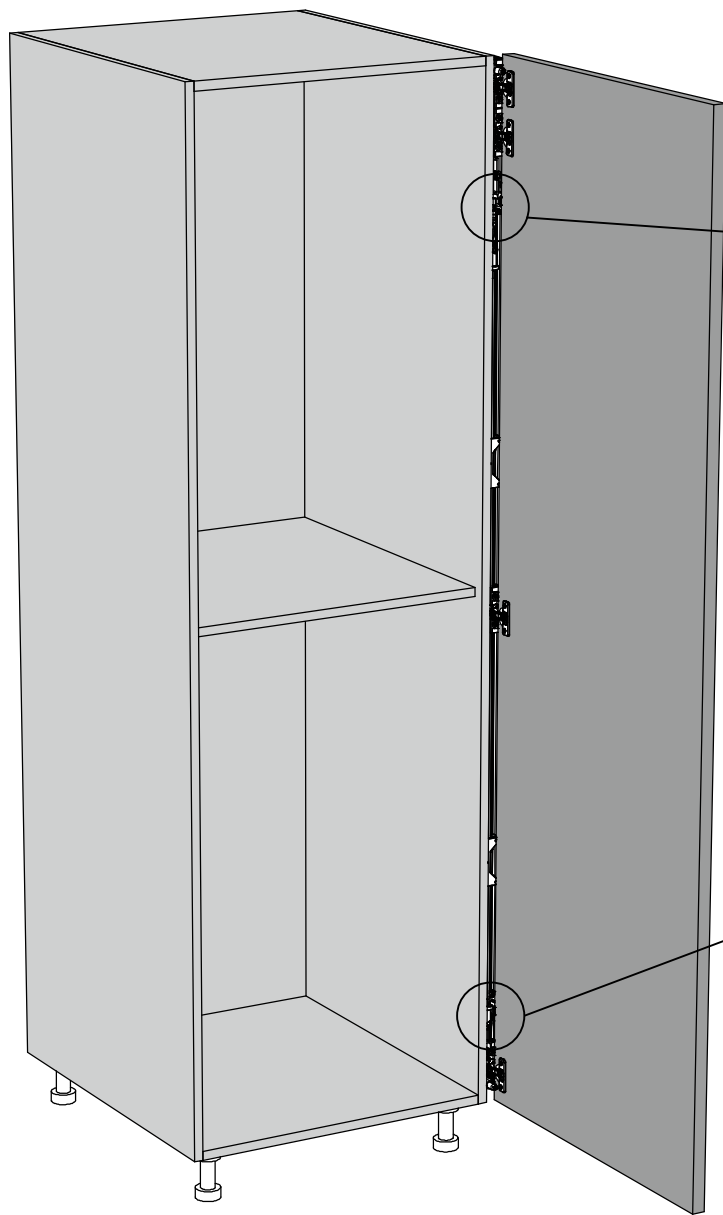

+2/-2 mm

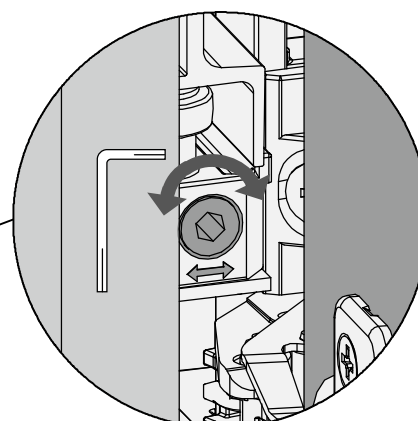

+2/-2 mm

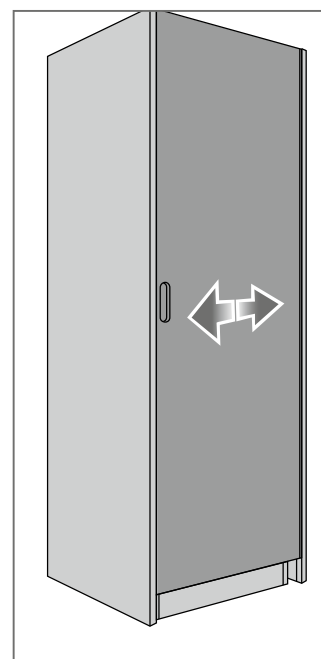
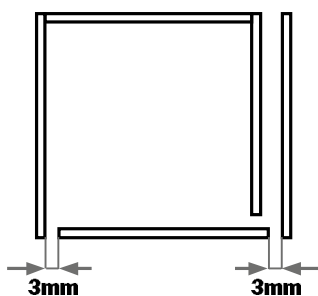

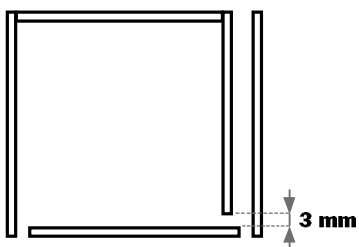
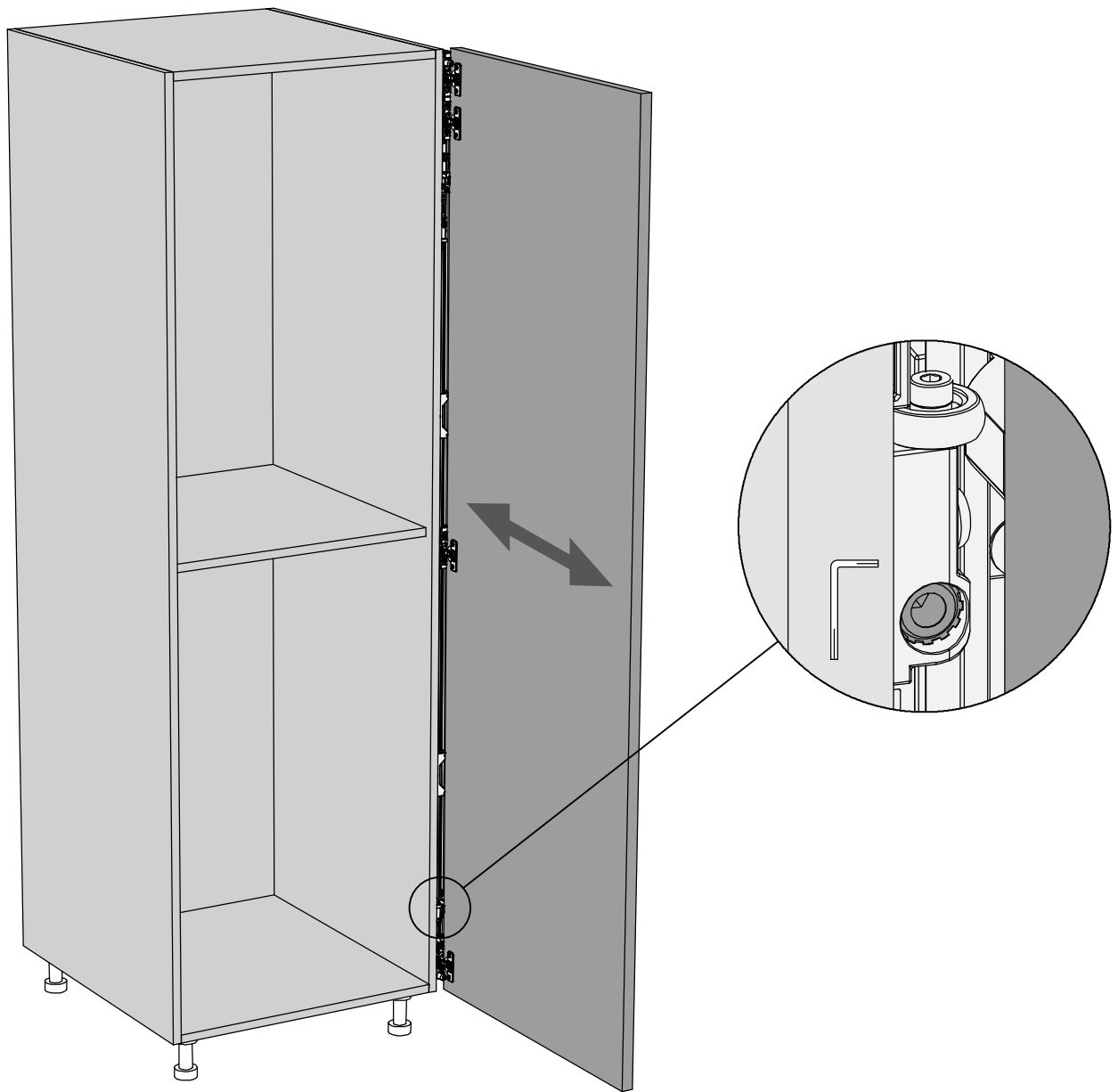

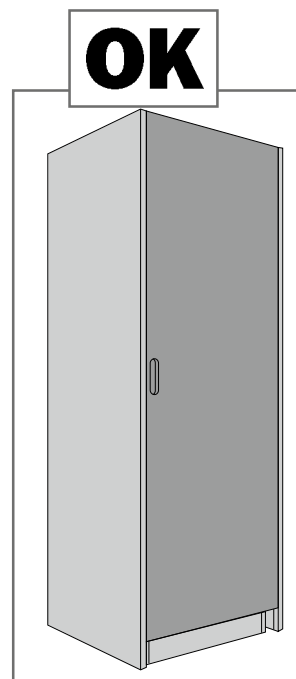
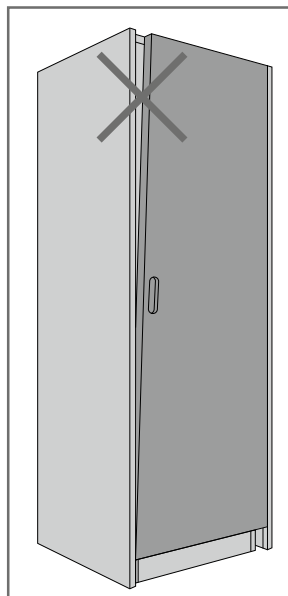
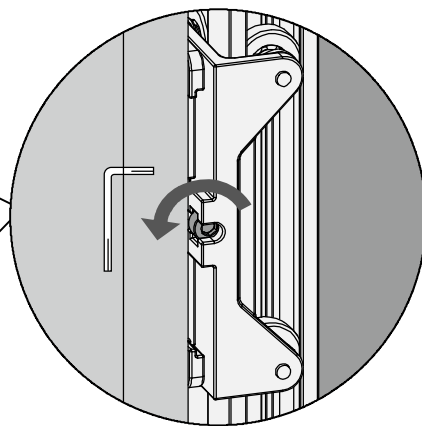
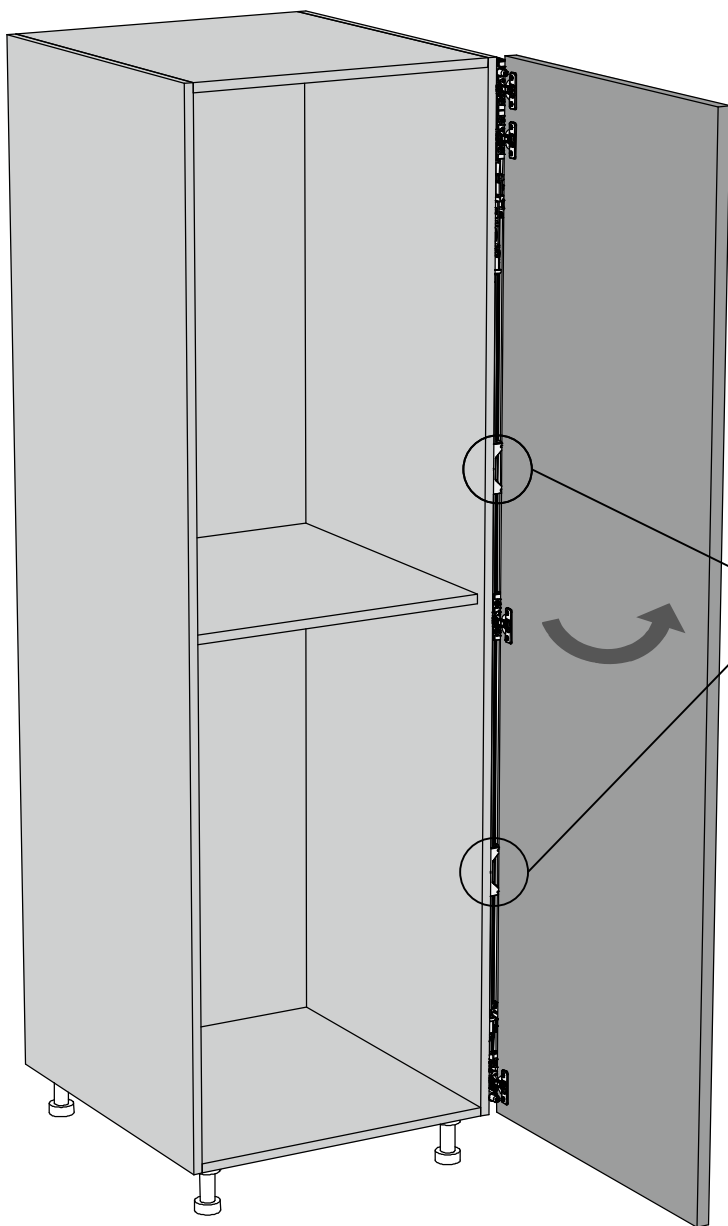

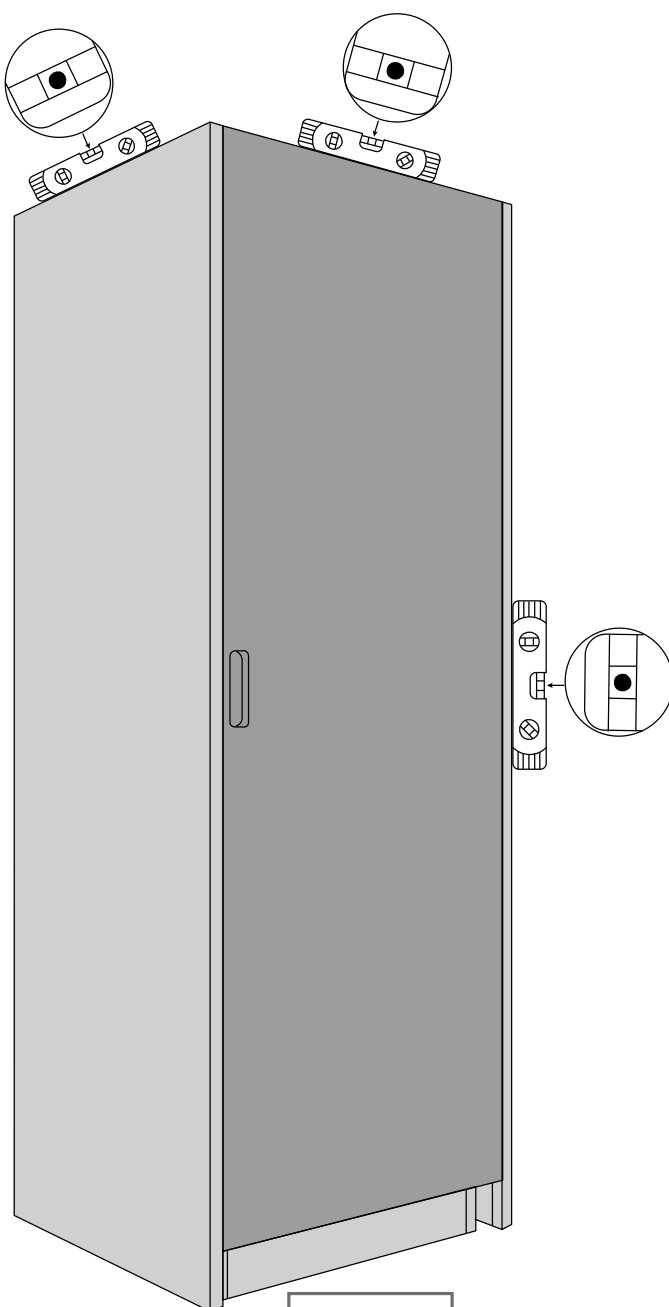
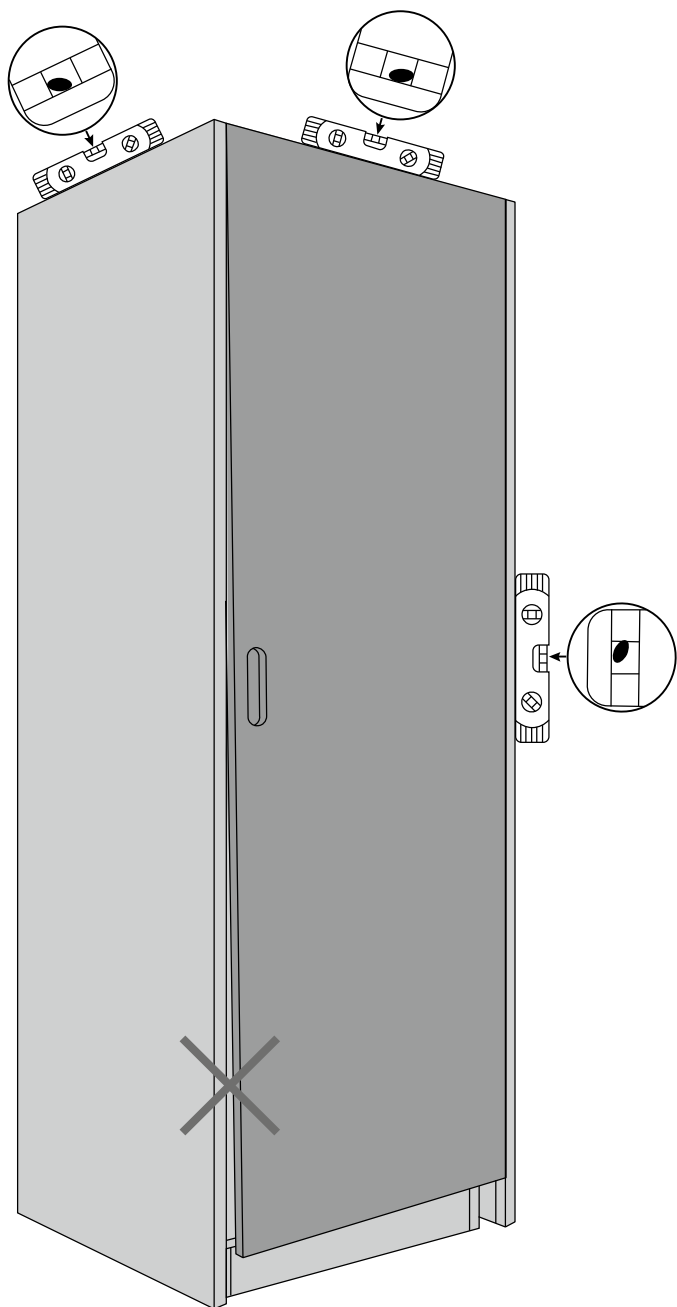

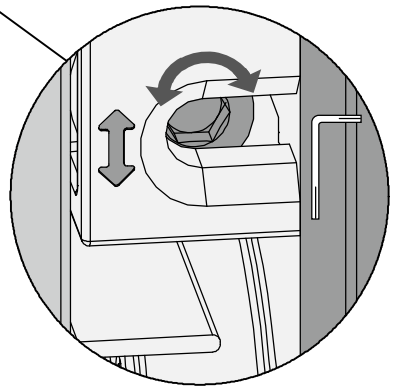
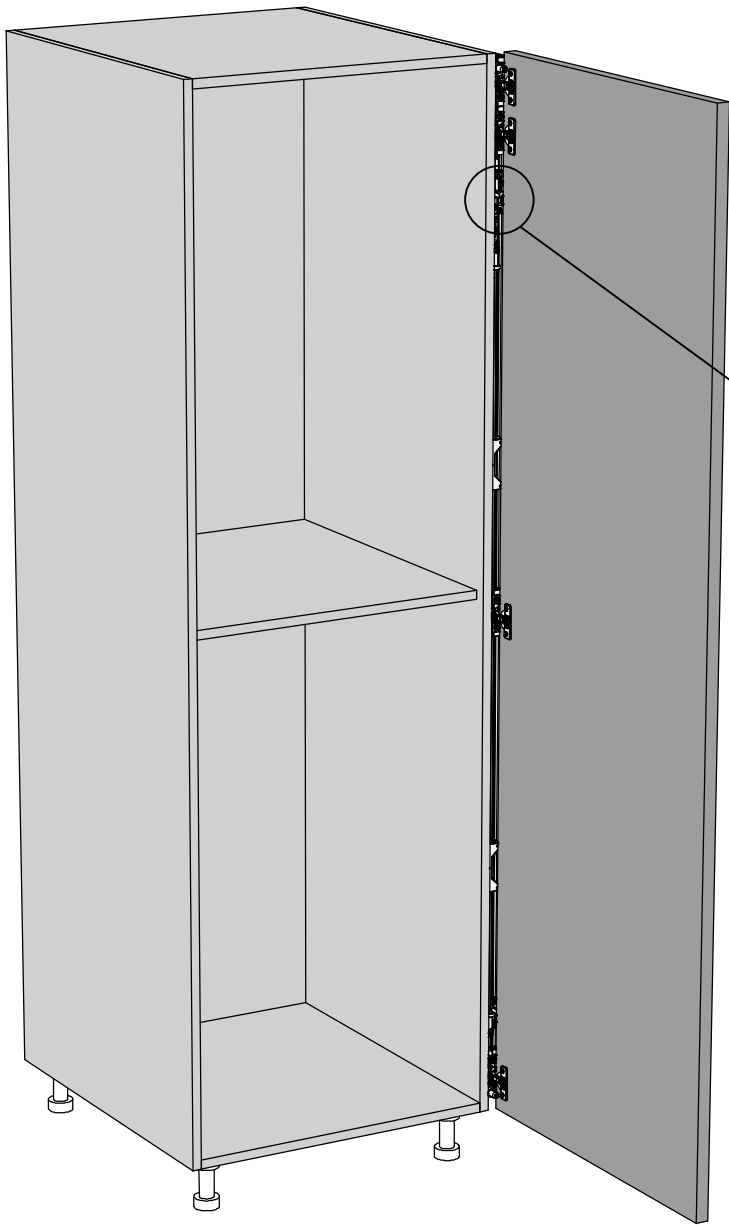

+4/-1 mm

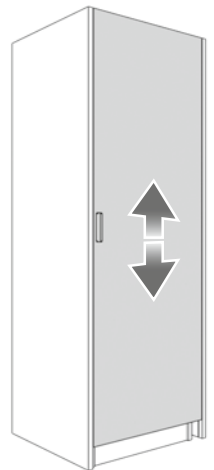

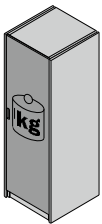
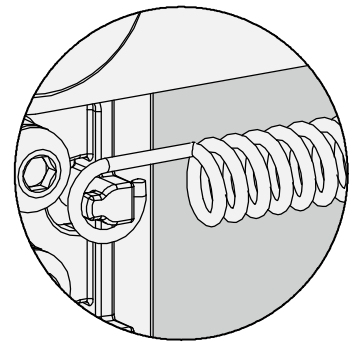
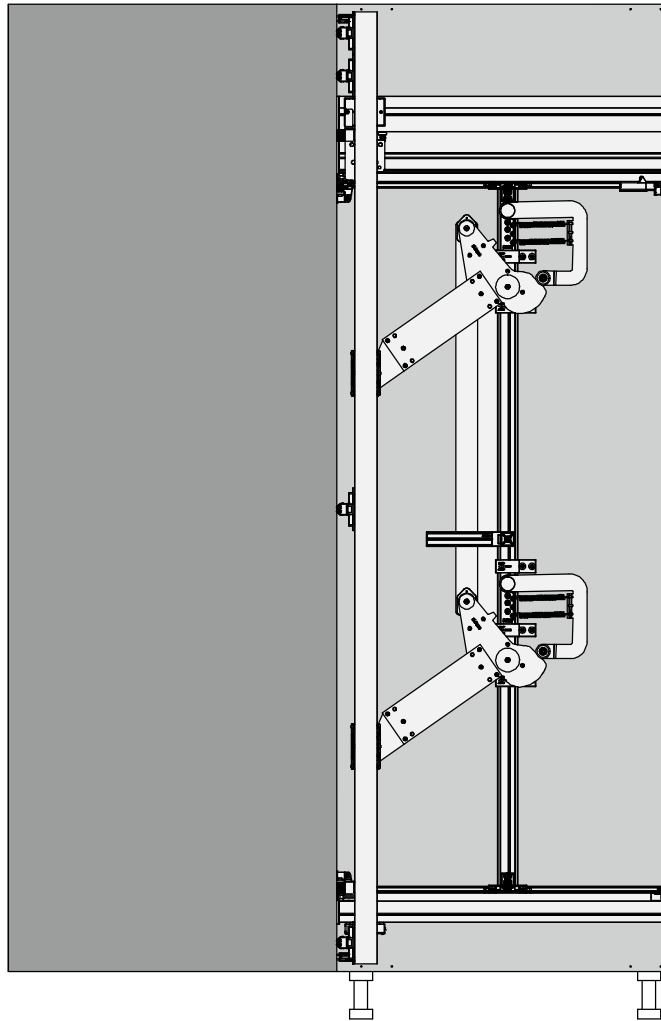
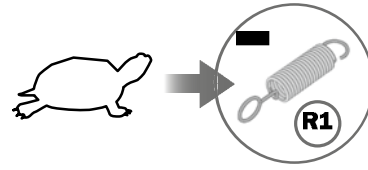
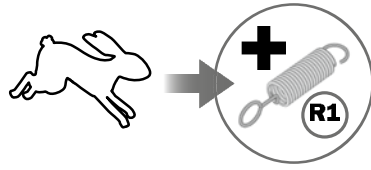

8-15 kg	15-21 kg	21-25 kg	25-28 kg	28-30 kg

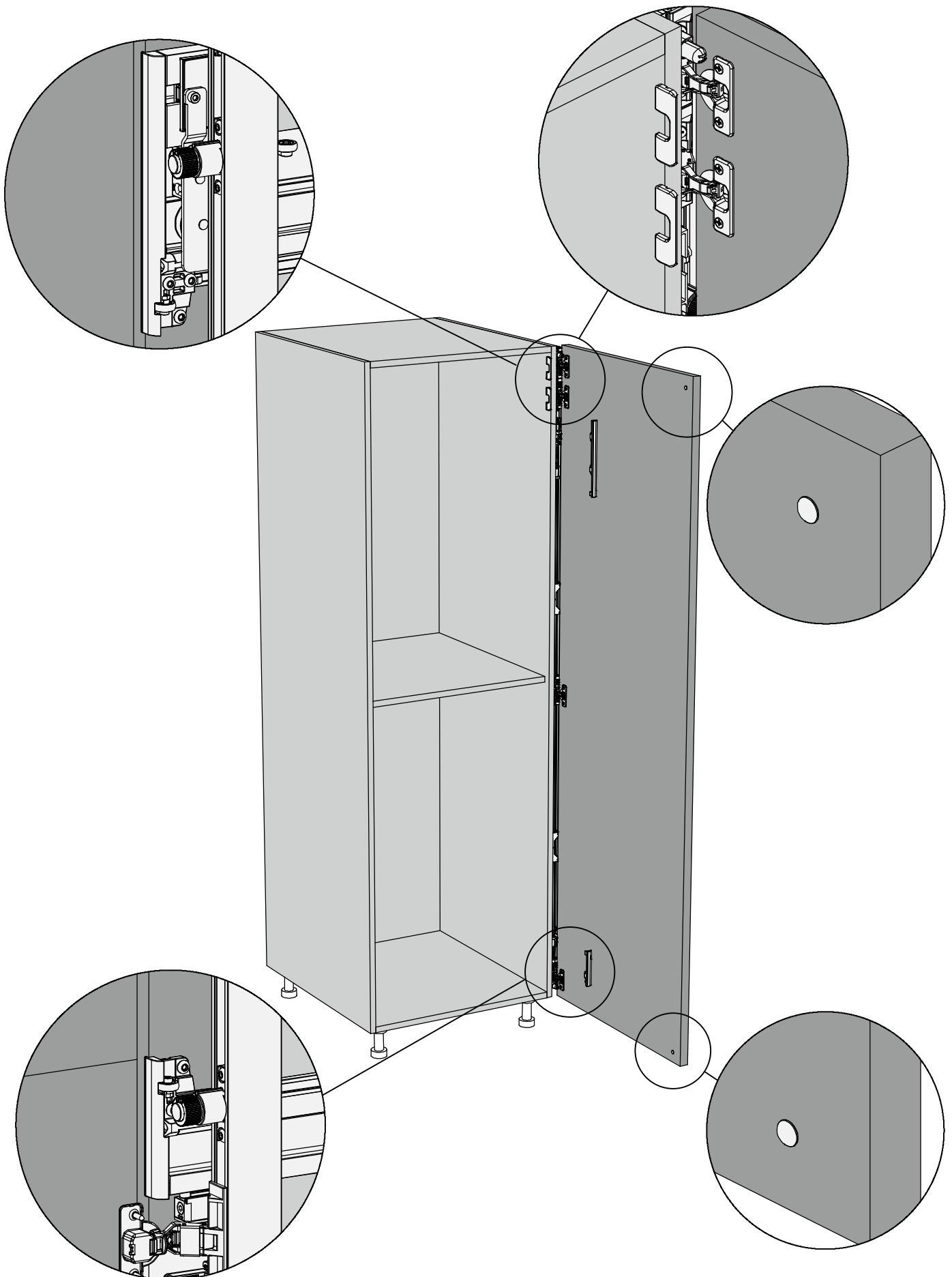

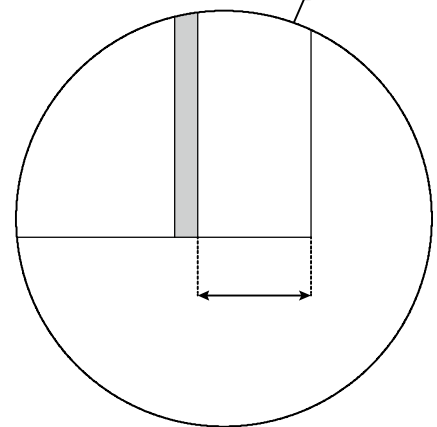
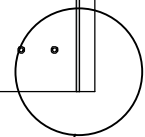
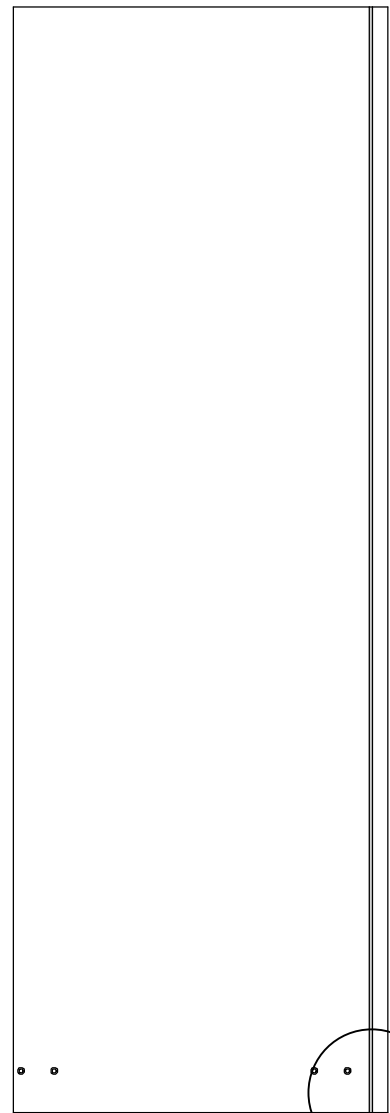
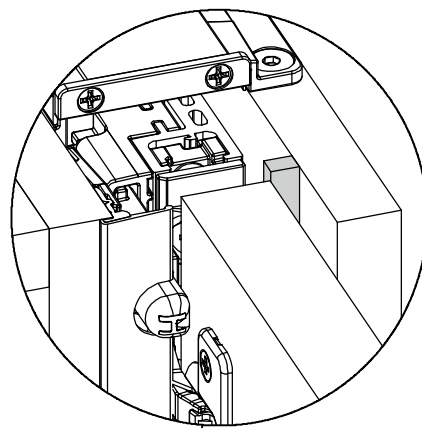
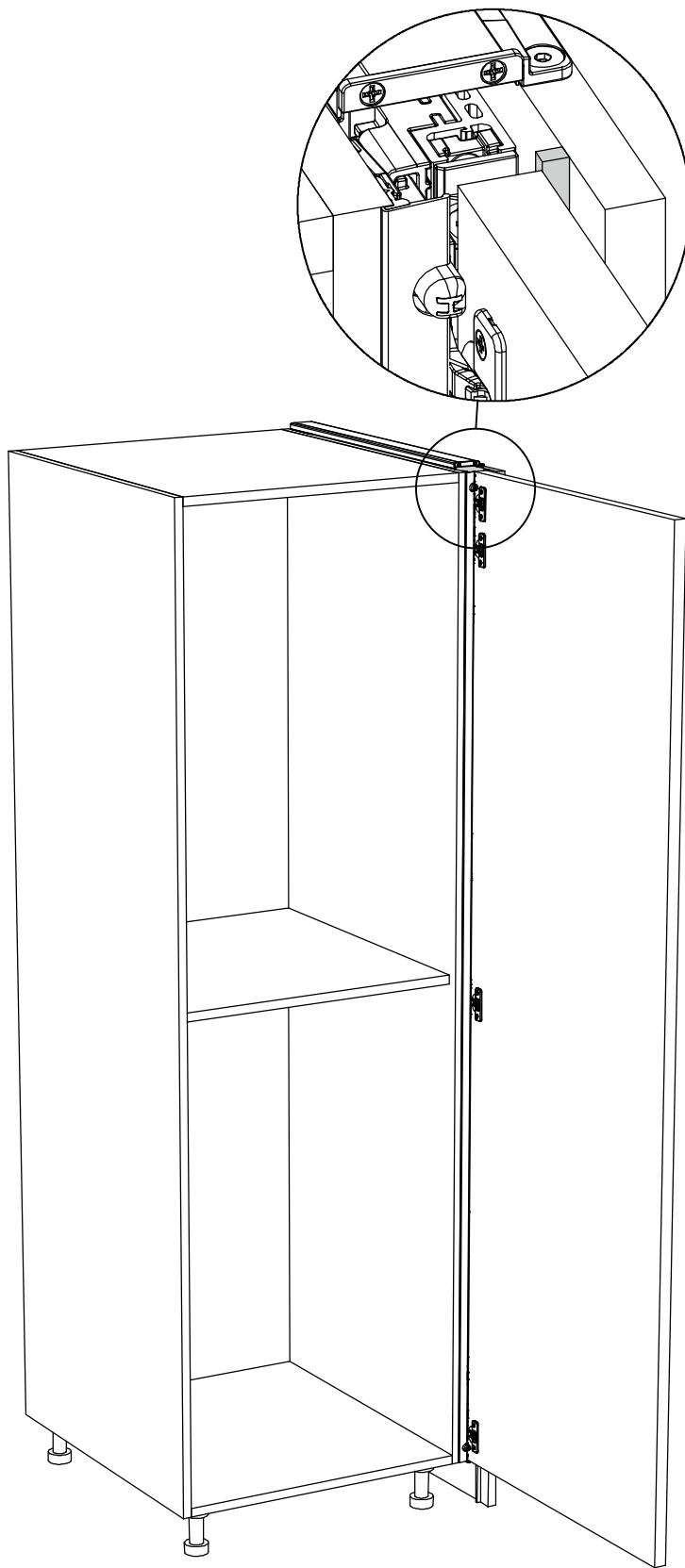

[ITA] Giunzione fianco struttura

[ENG] Side panel connector kits

[ESP] Conexión del lateral a la estructura

[DEU] Verbindung Seitenwand des Möbels

[POR] junção lateral da estrutura

[FRA] Joint d'assemblage latEral du meuble

[ZH] 间距盖条套装

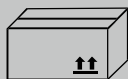

Part number

PS (mm)

(kg)

(m²)

(mm)

VE55KIT0001

400÷650

0,85

0,003

90 x 45 x 770

PERFIL SUJECIÓN COSTADO LATERAL "A"

VE55KIT0002

650÷900

1,0

0,004

90 x 45 x 1020

PERFIL SUJECIÓN COSTADO LATERAL "B"

VE55KIT0005

400÷650

0,85

0,003

90 x 45 x 770

VE55KIT0006

650÷900

1,0

0,004

90 x 45 x 1020

VE55KIT0003

400÷650

1,5

0,003

130 x 45 x 770

VE55KIT0004

650÷900

1,8

0,004

130 x 45 x 1020

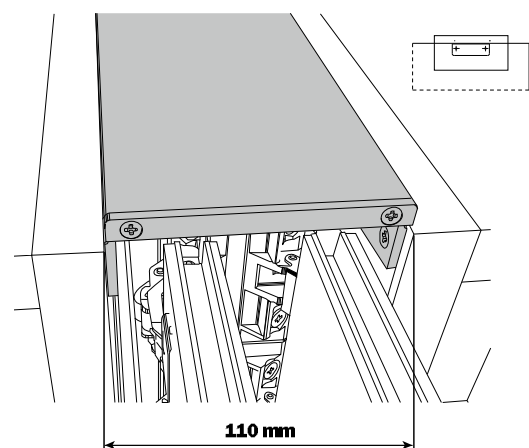
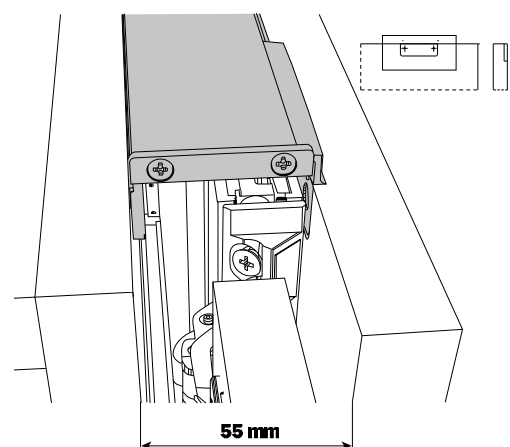
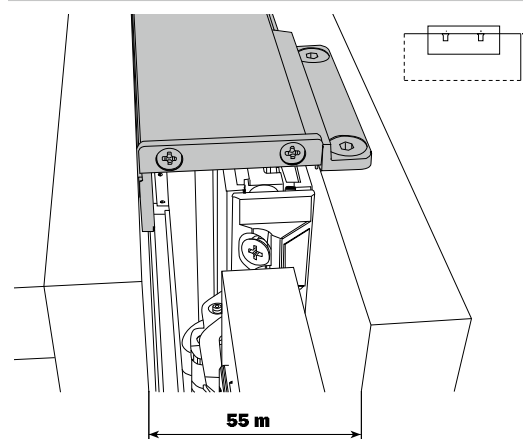

[ITA] **Kit copertura frontale**

[ENG] **Front cover strips**

[ESP] **Kit cobertura frontal**

[DEU] **Kit Frontabdeckung**

[POR] **Kit cobertura frontal**

[FRA] **Kit de cache frontal**

[ZH] 前挡尘条

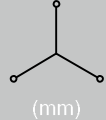
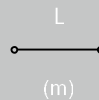
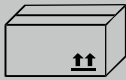

Part number



(m)

(kg)

(m³)

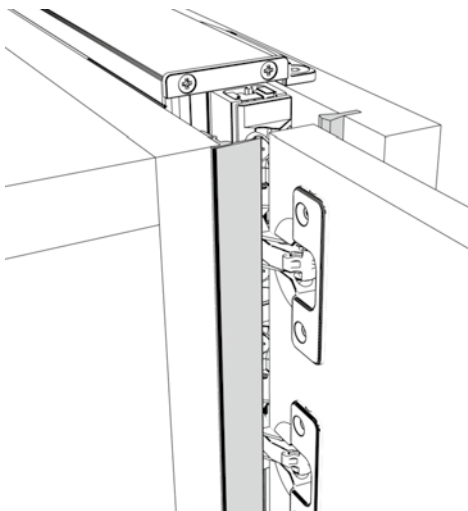
(mm)



VE55KIT0201	2,6		0,7	0,03	100 x 100 x 2700
VE55KIT0202	2,6		0,7	0,03	100 x 100 x 2700
VE55KIT0203	2,6		0,7	0,03	100 x 100 x 2700

[ITA] **Deceleratore smove**

[ENG] **Smove damper**

[ESP] **Amortiguador smove**

[DEU] **Smove Dämpfer**

[POR] **Desacelerador smove**

[FRA] **Amortisseur smove**

[ZH] 闭门阻尼器

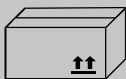

Part number

pcs.

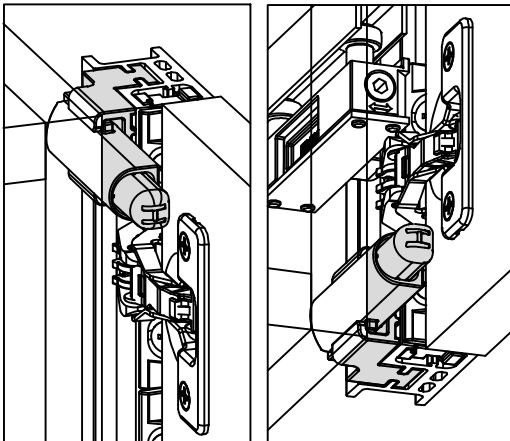

YE55KIT0050

Kit con 2 Smove per ante con 3 cerniere
 Kit with 2 Smove for doors with 3 hinges
 Kit mit 2 Smove für Türen mit 3 Scharnieren
 Kit avec 2 Smove pour portes avec 3 charnières
 Kit con 2 Smove para puertas con 3 bisagras
 Kit com 2 Smove para portas com 3 dobradiças
 套装包含 2 个 Smove 阻尼, 用于 3 只铰链的门板

1

YE55KIT0055

Kit con 2 Smove per ante con 4 e 5 cerniere
 Kit with 2 Smove for doors with 4 and 5 hinges
 Kit mit 2 Smove für Türen mit 4 und 5 Scharnieren
 Kit avec 2 Smove pour portes avec 4 et 5 charnières
 Kit con 2 Smove para puertas con 4 y 5 bisagras
 Kit com 2 Smove para portas com 4 e 5 dobradiças
 套装包含 2 个 Smove 阻尼, 用于 4-5 只铰链的门板

1

[ITA] Lavorazioni sul fianco

[ENG] Cover panel drillings

[ESP] Trabajos en el lateral

[DEU] Bearbeitungen der seite

[POR] Usinagens na lateral

[FRA] Opérations sur le côté

[ZH] 侧板孔位

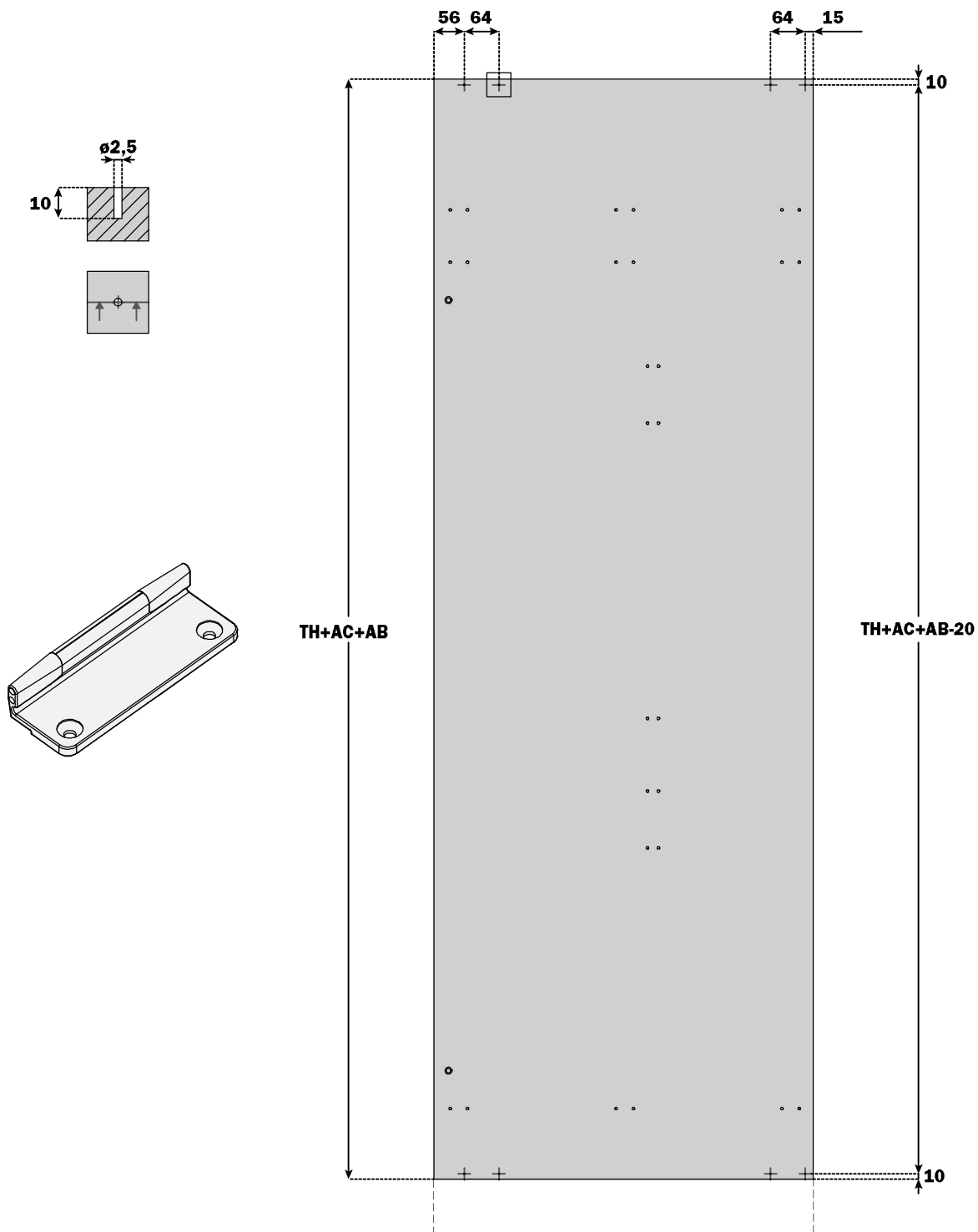

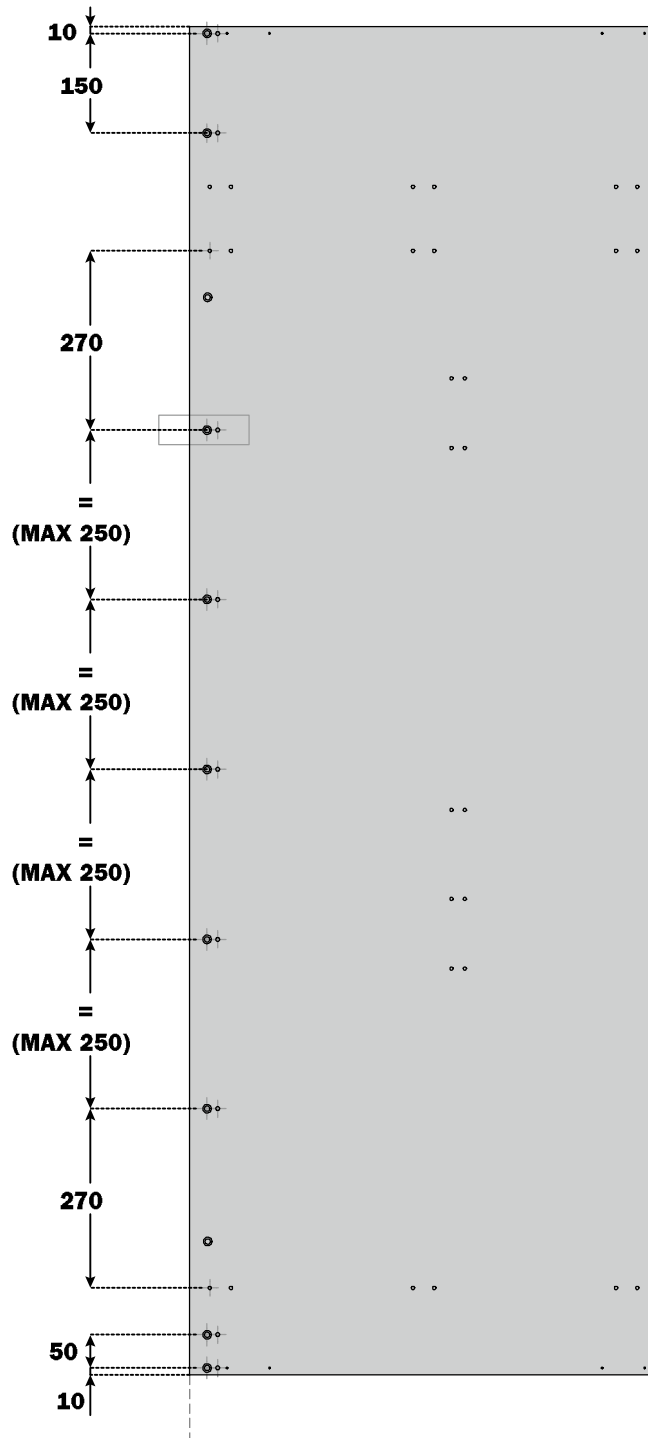
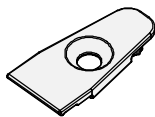
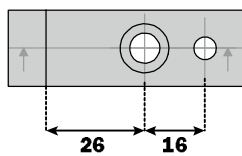
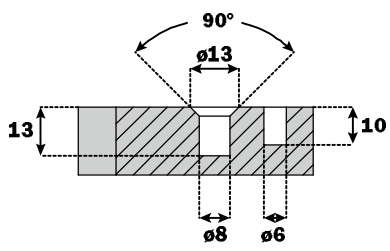

[ITA] Lavorazioni sul fianco di copertura

[ENG] Workings on the side cover

[ESP] Mecanizados en el lateral de cobertura

[DEU] Bearbeitungen der Abdeckseite

[POR] Usinagens na lateral de cobertura

[FRA] Opérations sur le panneau de recouvrement

[ZH] 外封板孔位、加工

VE55KIT0001 - 2

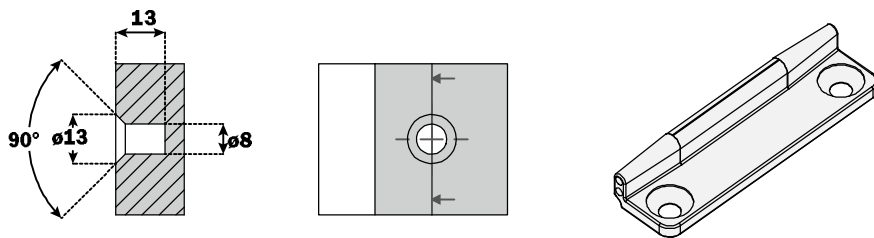
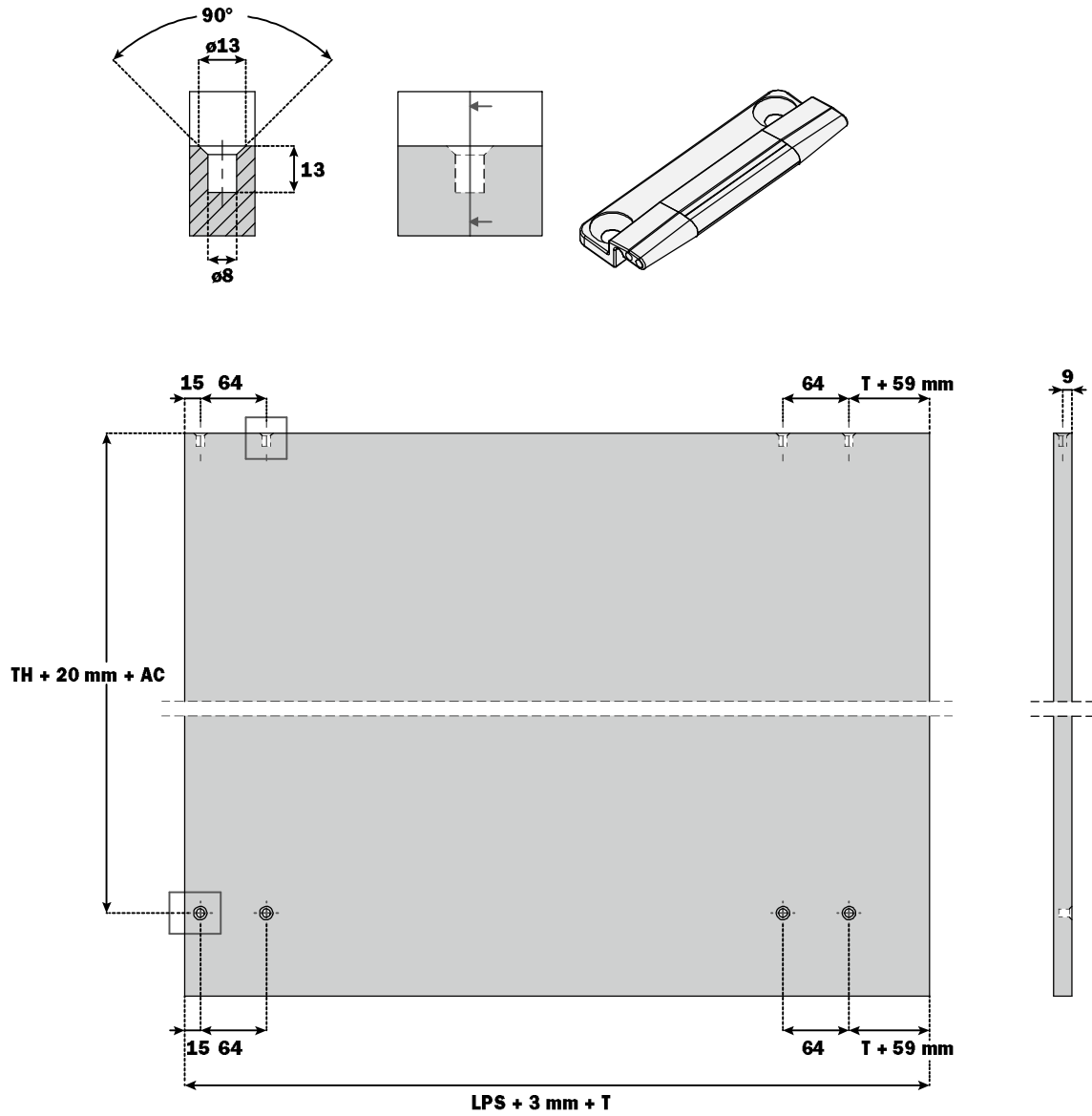

VE55KIT0003 - 4 - 5 - 6

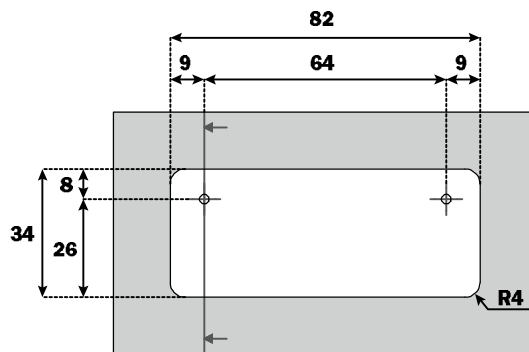
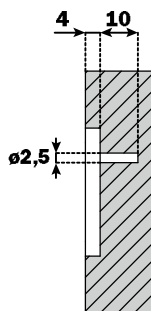
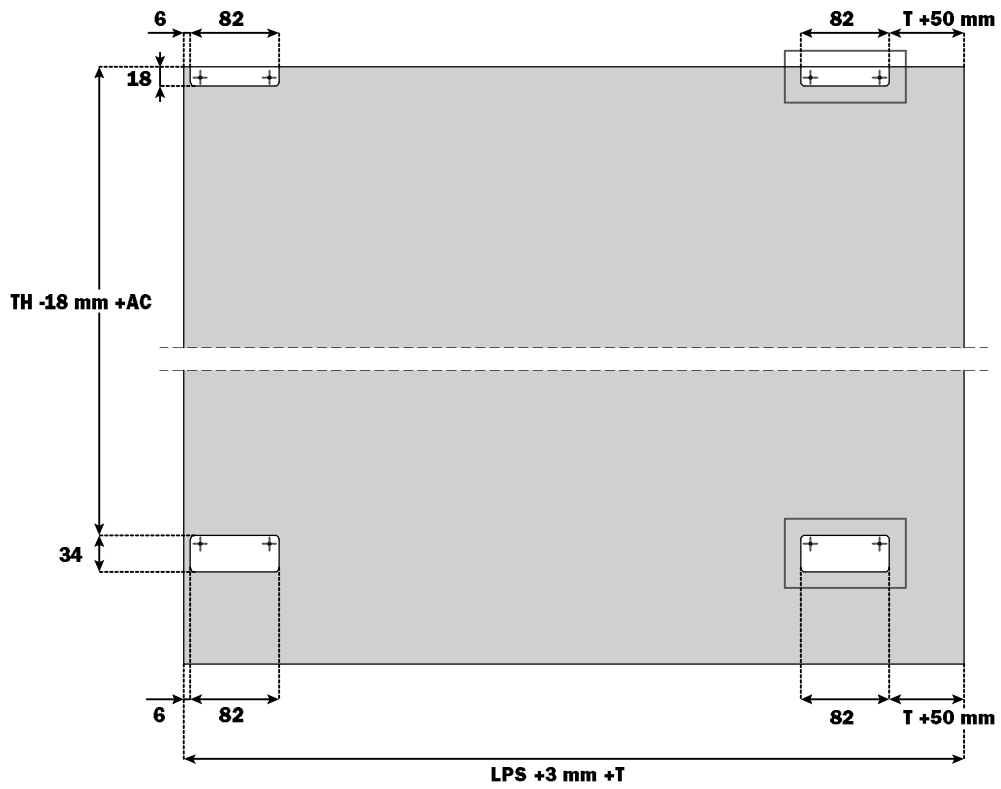
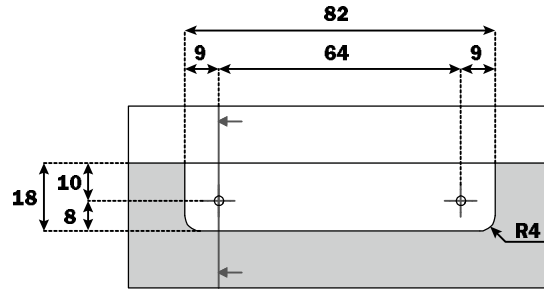
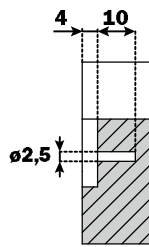
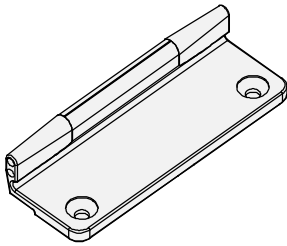

[ITA] Montaggio collegamenti sul fianco

[ENG] Fitting the brackets to the side panel

[ESP] Montaje de las conexiones en el lateral

[DEU] Montage der Verbindungen an der Seite

[POR] Montagem dos conectores na lateral

[FRA] Montage des joints d'assemblage latéraux sur le côté

[ZH] 安装间距盖条

VE55KIT0001 - 2 - 3 - 4 - 5 - 6

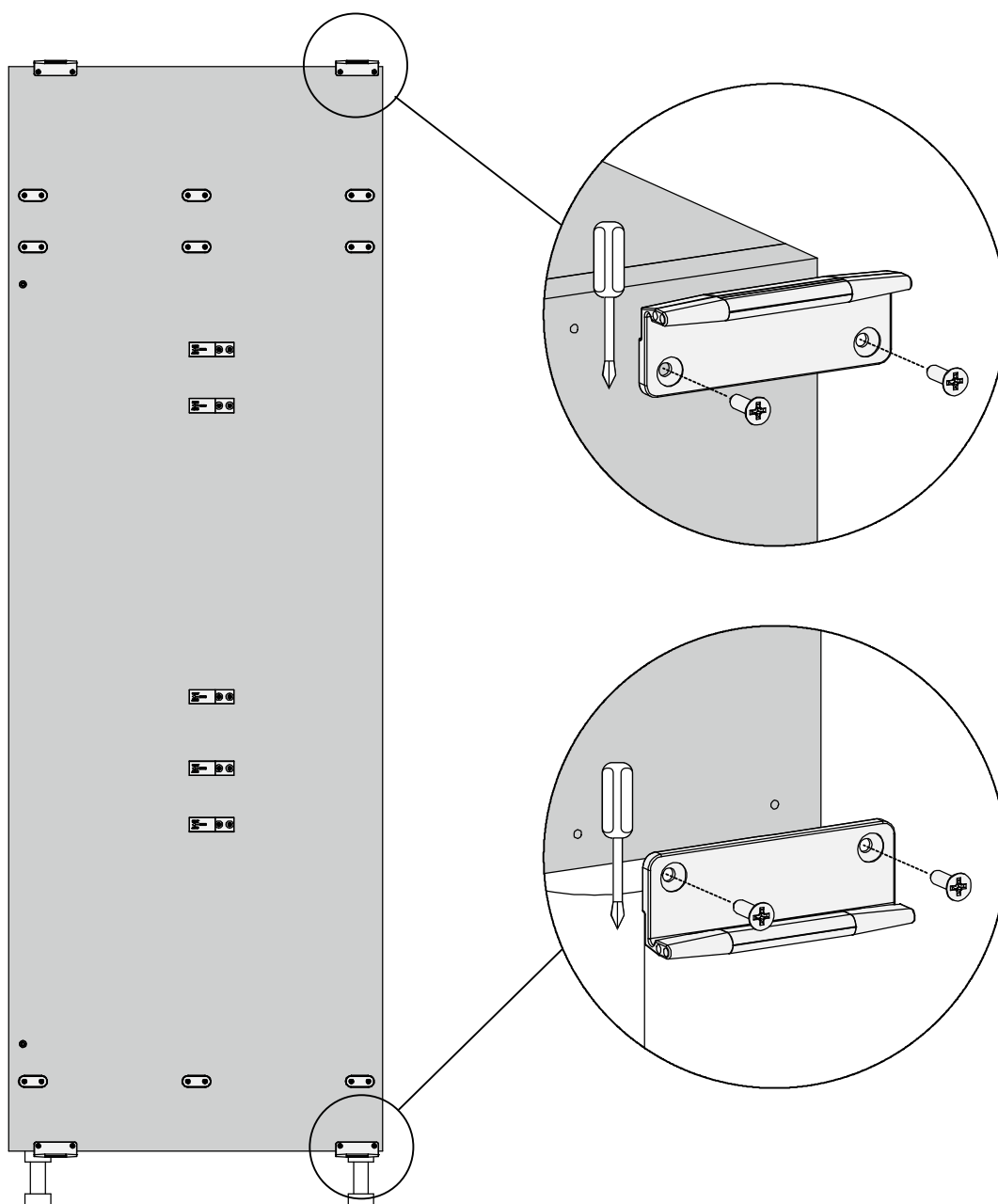

VE55KIT001 - 2

VE55KIT0201 - 2 - 3

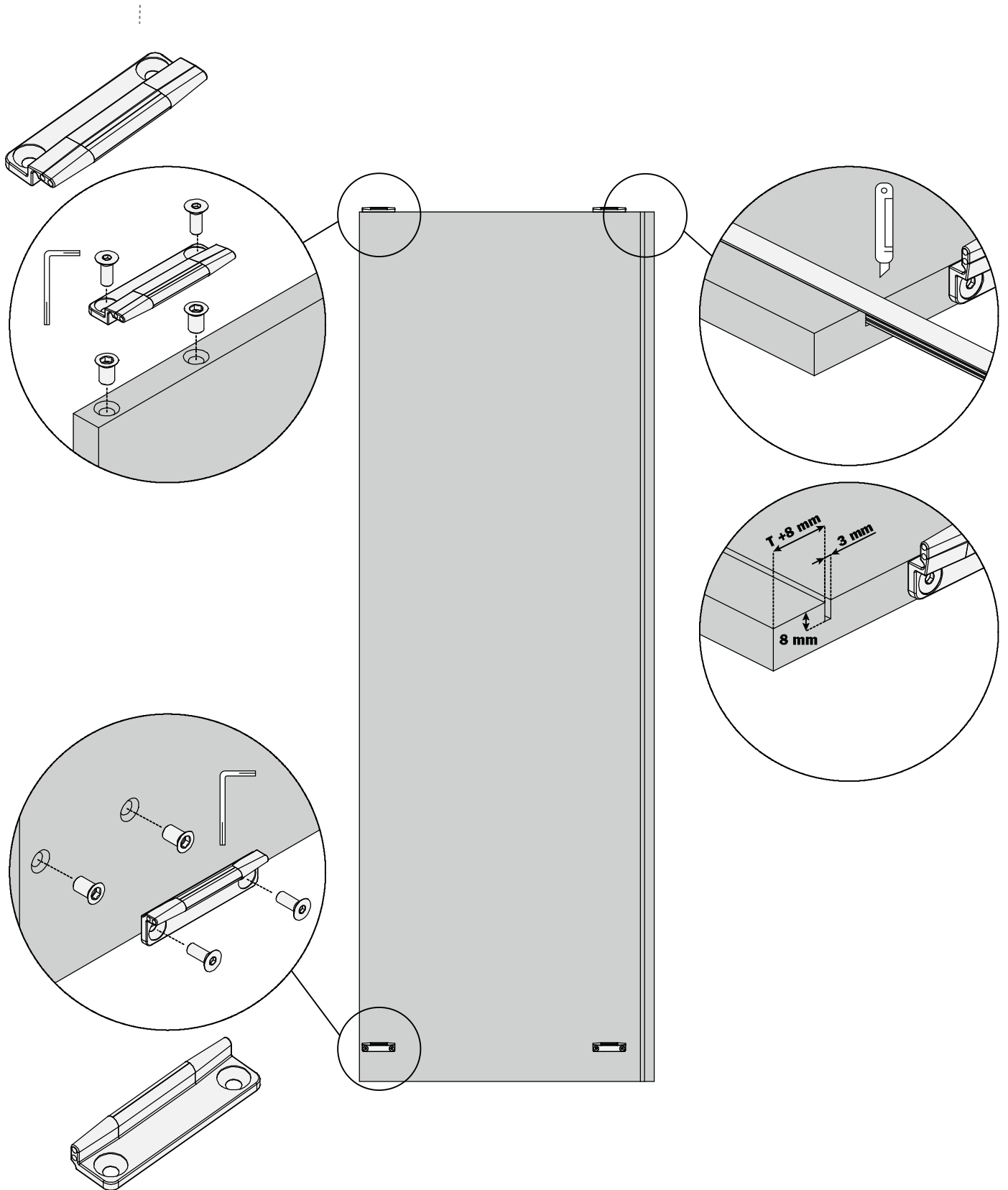

VE55KIT005 - 6

VE55KIT0201 - 2 - 3

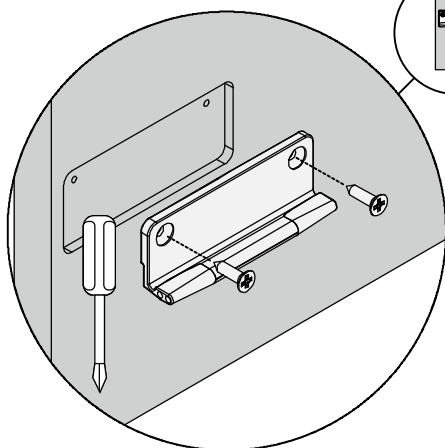
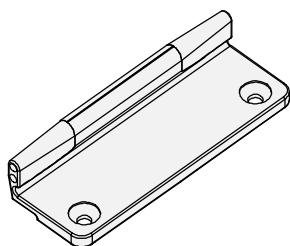
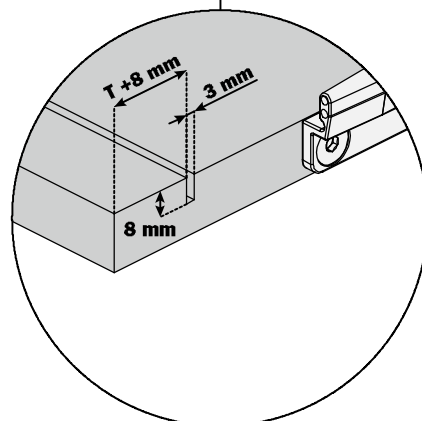
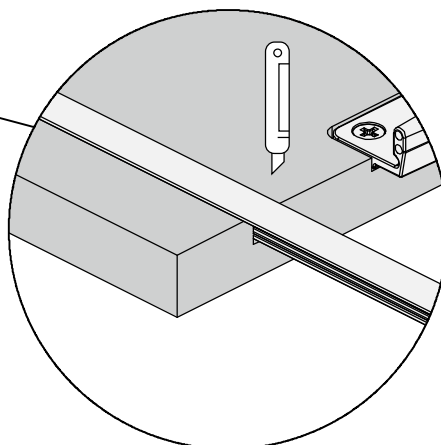
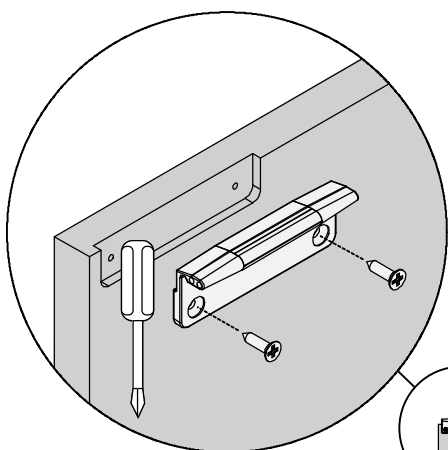

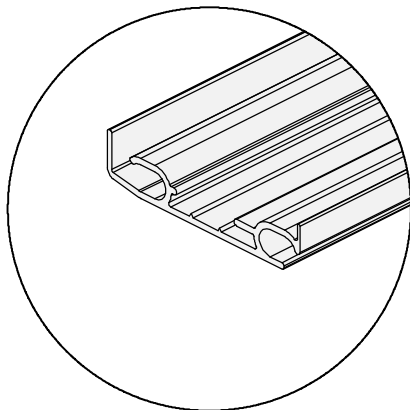
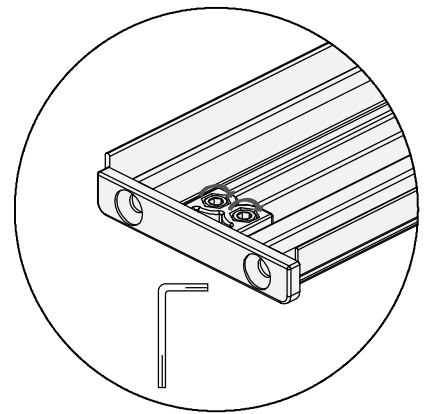
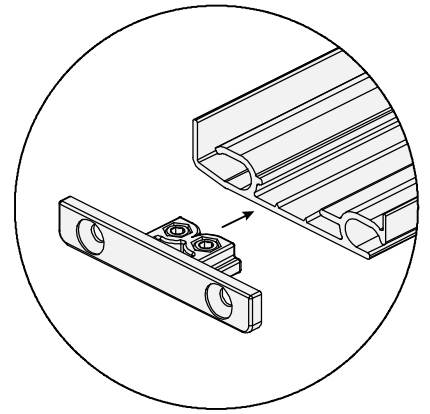
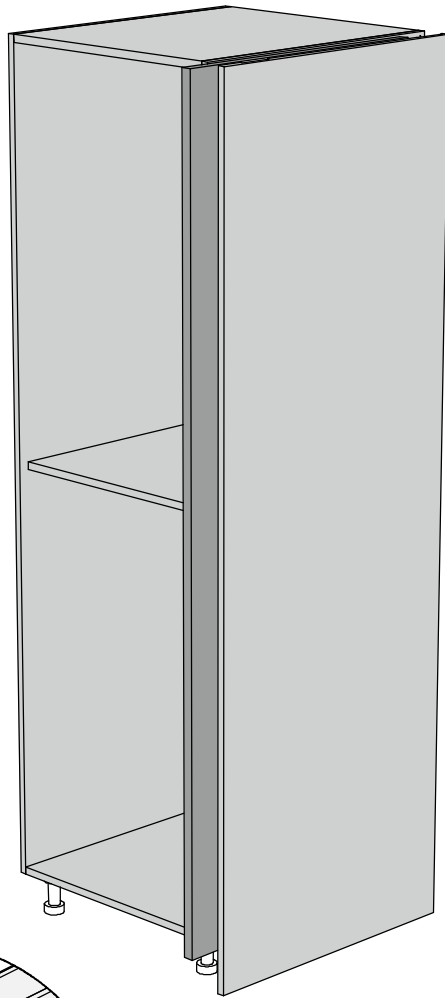
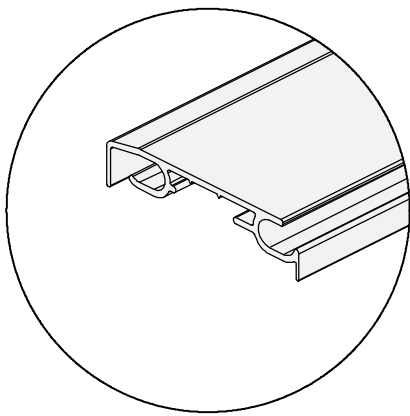
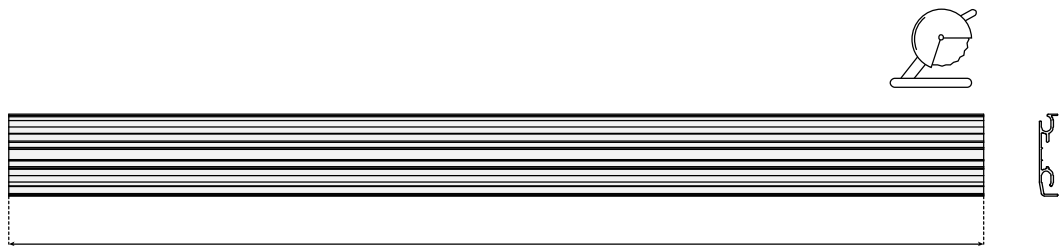

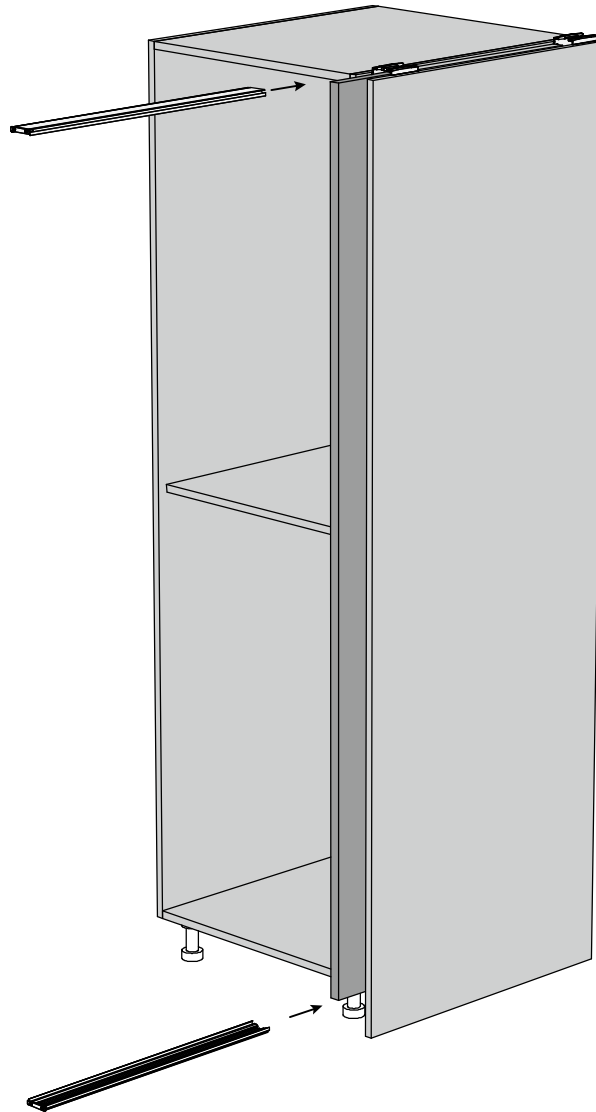
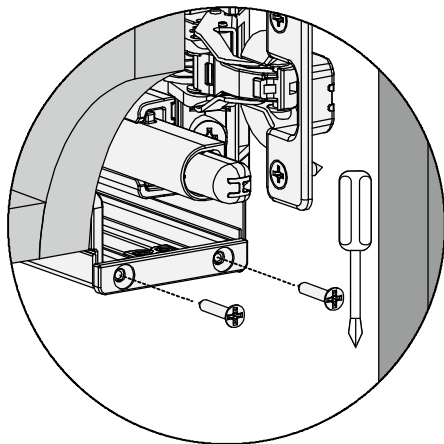
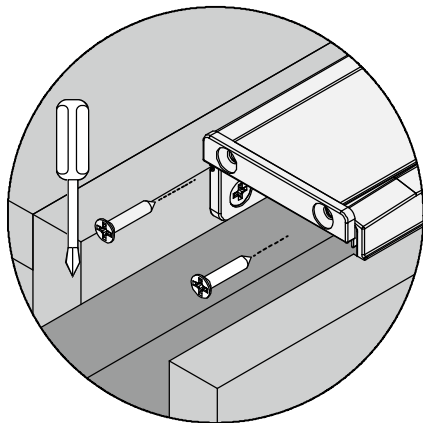
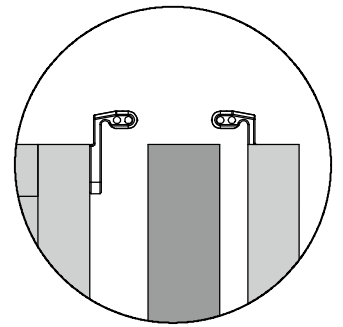
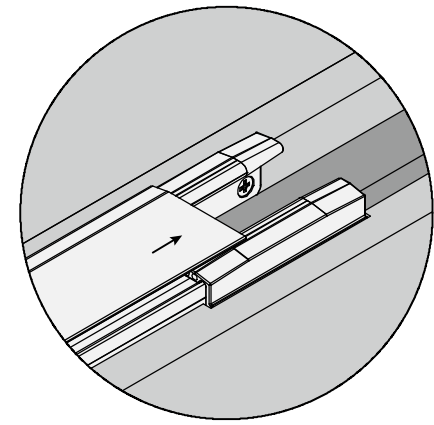

VE55KIT0003 - 4

LPS - 55 mm

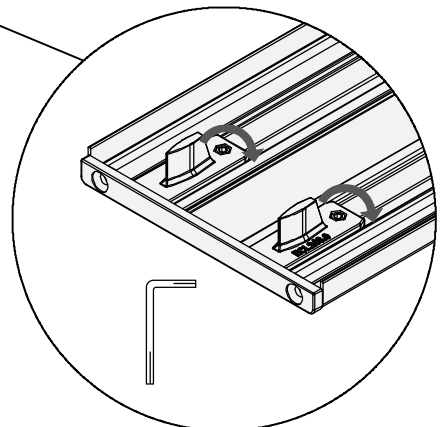
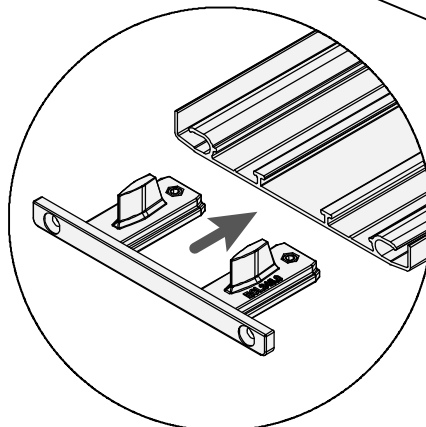
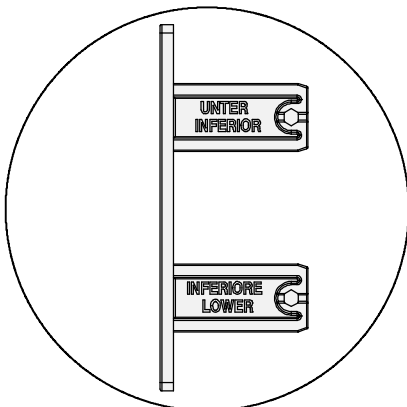
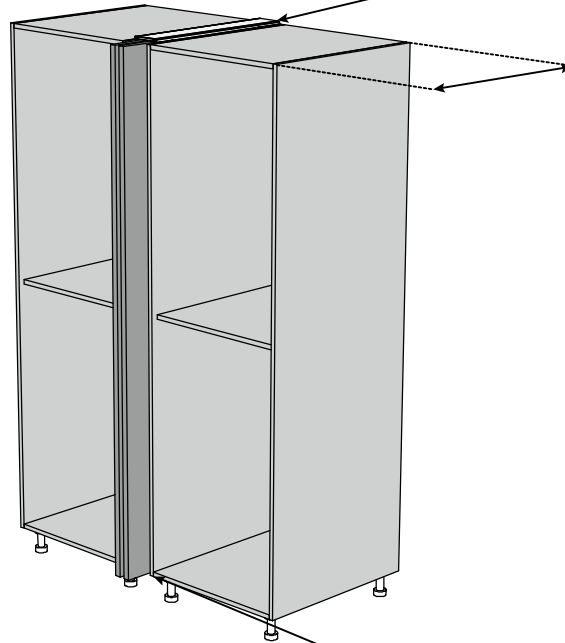
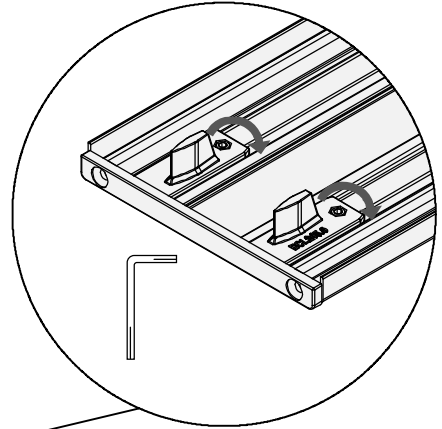
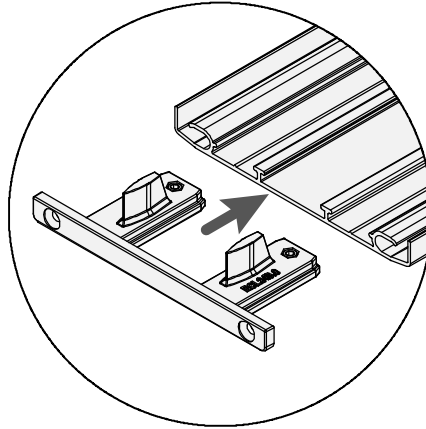
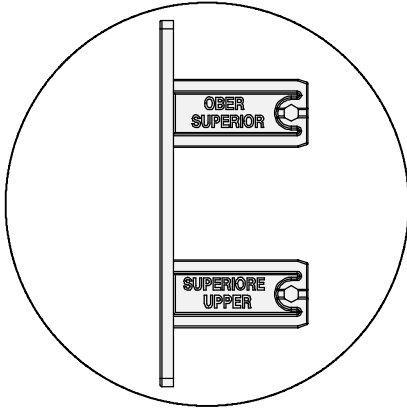
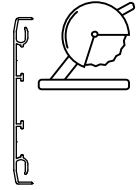
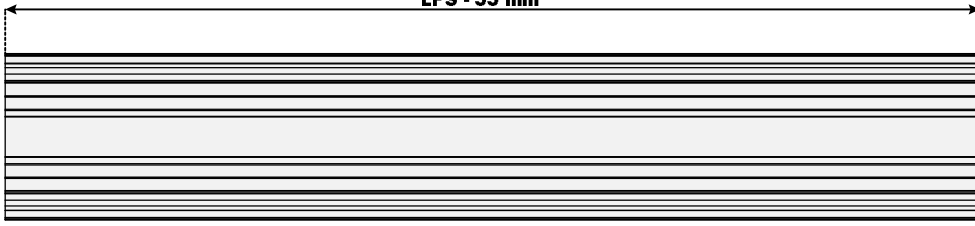

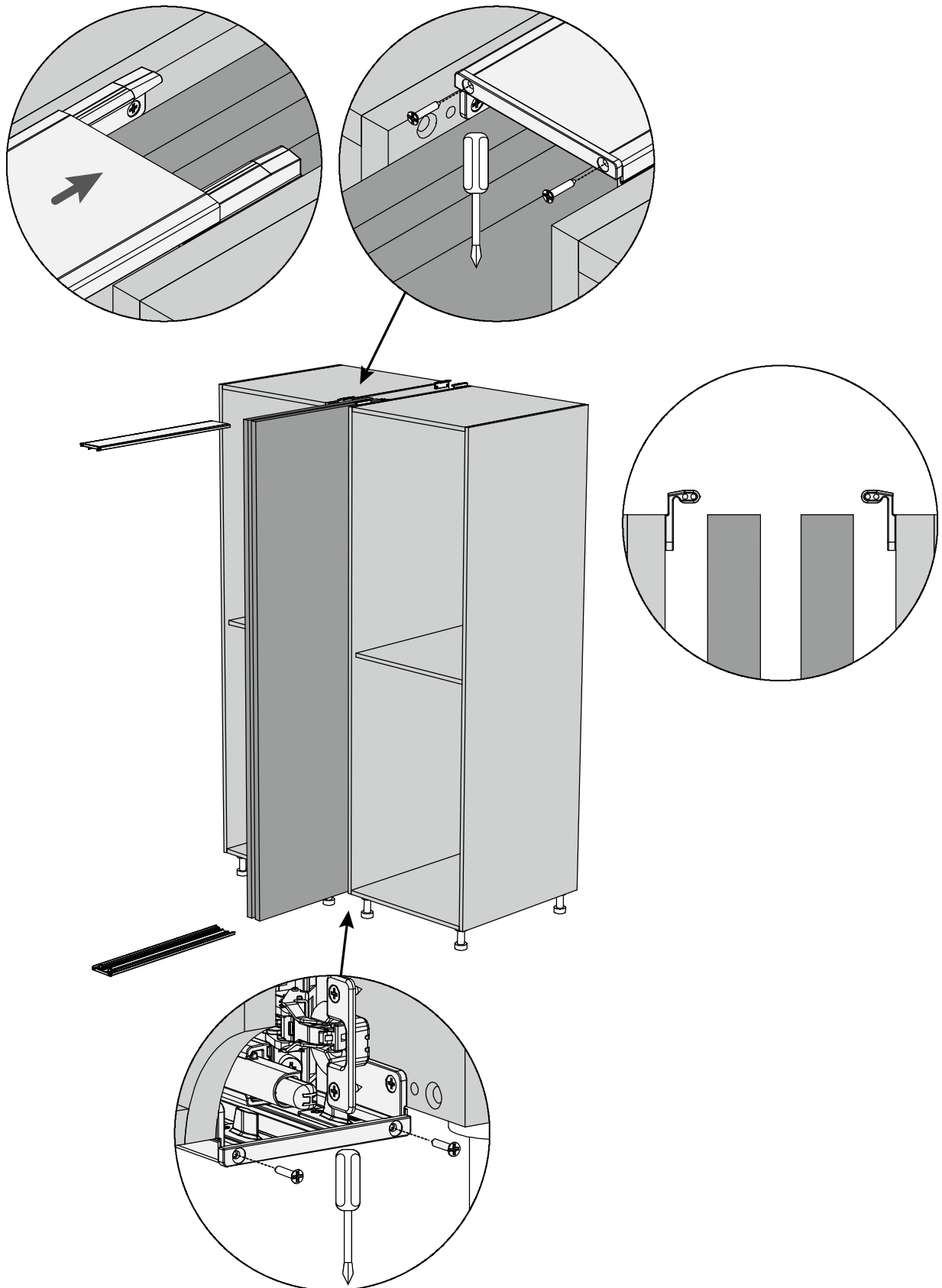

[ITA] Applicazione del profilo di copertura

[ENG] Fitting the cover strips

[ESP] Aplicación del perfil de cobertura

[DEU] Befestigung des Abdeckprofils

[POR] Aplicação do perfil de cobertura

[FRA] Installation du profile de recouvrement

[ZH] 安装前挡尘条

VE55KIT0201 - 2 - 3

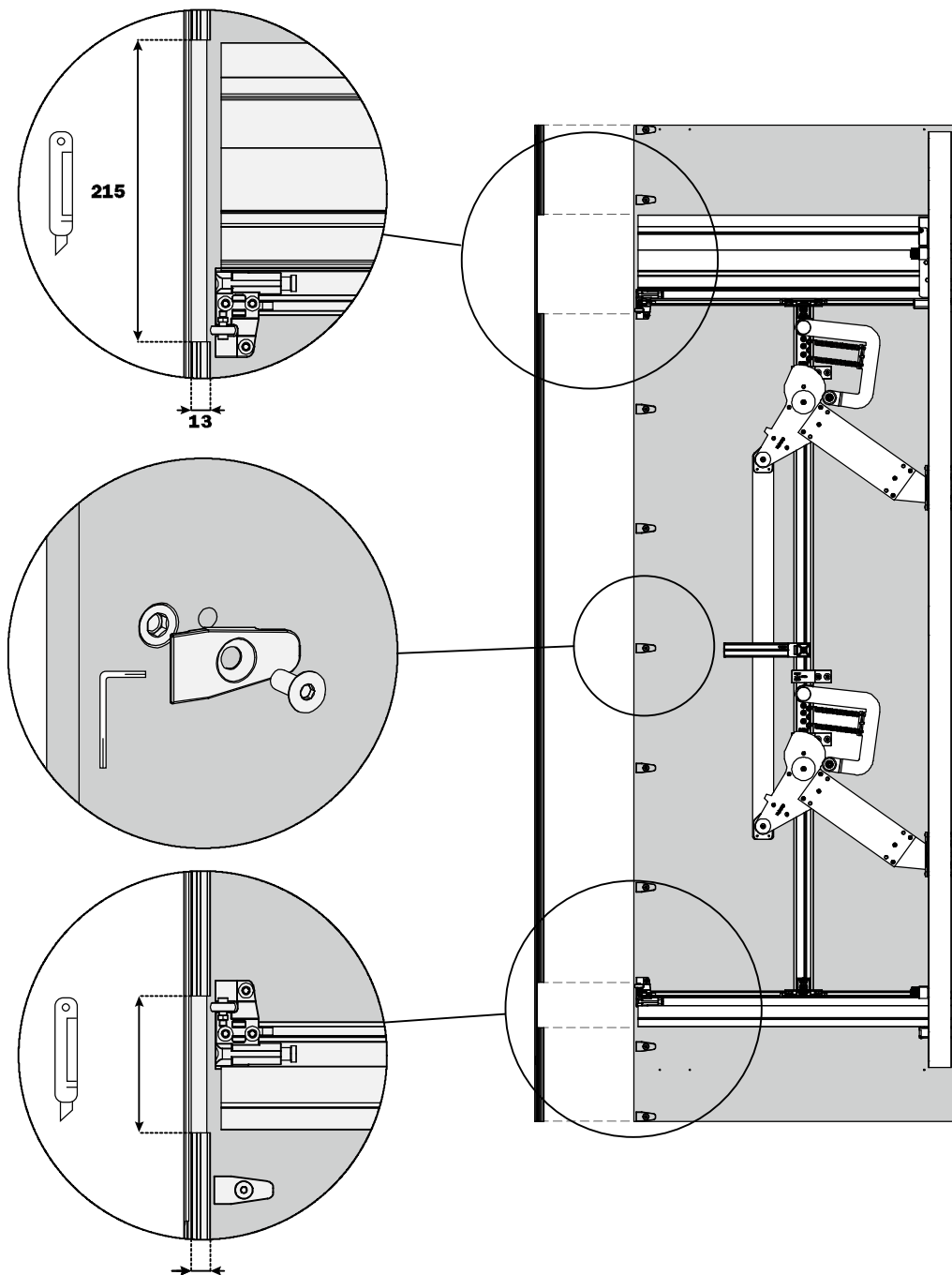

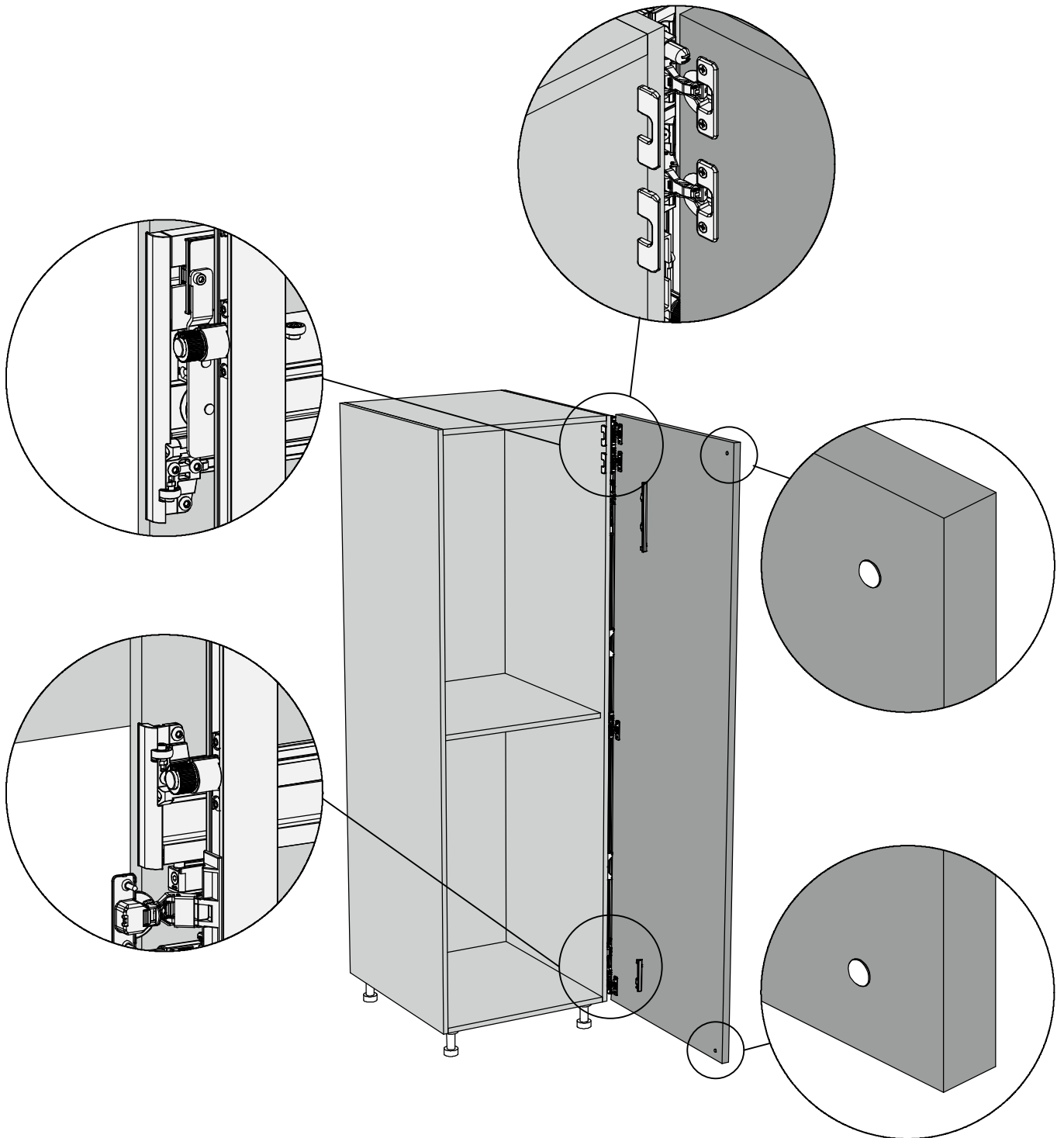

VE55KIT0050
VE55KIT0055

