

SESTANTE

ISTRUZIONI DI MONTAGGIO ASSEMBLY INSTRUCTIONS

MODELLI - MODELS:

- 411/78.1290.22R - SESTANTE 600 (GAMBA REGOLABILE - ADJUSTABLE LEG)
- 411/78.1291.22R - SESTANTE 700 (GAMBA REGOLABILE - ADJUSTABLE LEG)
- 411/78.1292.22R - SESTANTE 800 (GAMBA REGOLABILE - ADJUSTABLE LEG)
- 411/78.1293.22R - SESTANTE 900 (GAMBA REGOLABILE - ADJUSTABLE LEG)

CONTENUTO DELLA CONFEZIONE INCLUDED IN THE PACKAGING

- CARRELLO - CART
- GUIDE - SLIDES
- SOSTEGNO - SUPPORT
- GAMBA - LEG

SACCHETTO ACCESSORI 1 - ACCESSORIES 1
(Per tutti i modelli - For all models)

- A. Chiave esa. n.4 - n.4 Allen key
- B. Bussola M6 - M6 bush (x 19)
- C. Feltro 560 mm - Felt 560 mm (x 1)
- D. Feltro 30 mm - Felt 30 mm (x 2)
- E. Vite truciolare 3.5x24 - 3.5x24 FHP screw (x 3)
- F. Vite TCB M6x12 - M6x12 BHCS screw (x 13)
- G. Vite TPS M6x12 - M6x12 FHCS screw (x 6)
- H. Pattino - Runner (x 2)

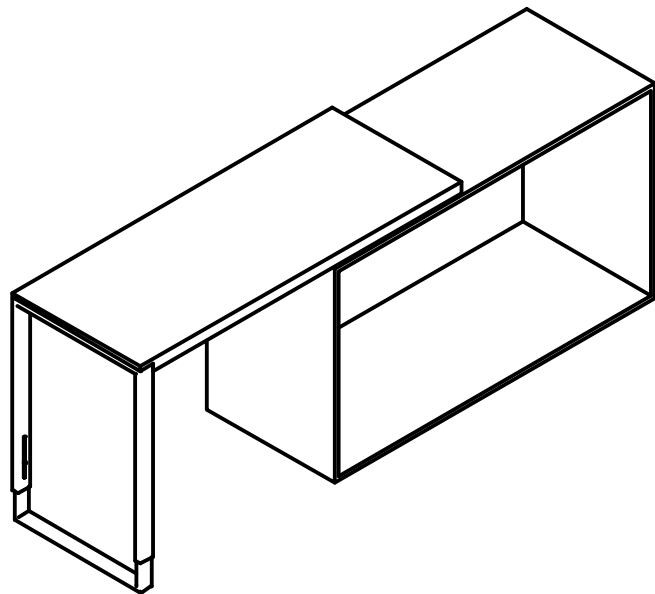

DIMENSIONI GENERALI GENERAL SIZES

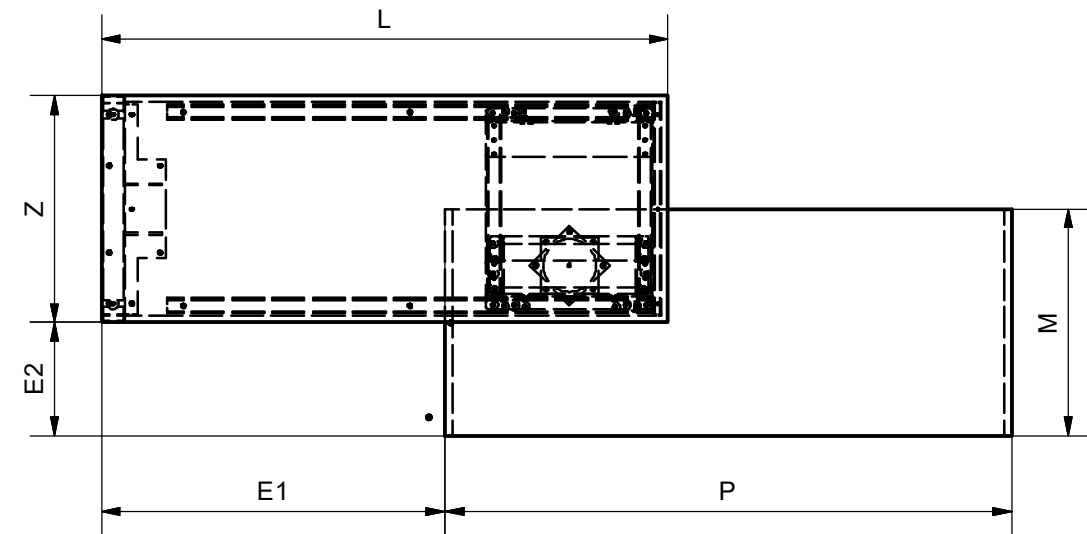
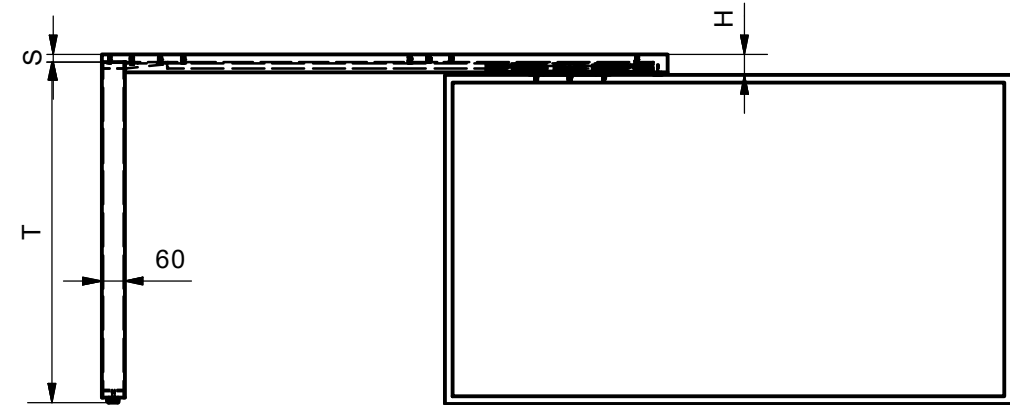

DIMENSIONE - DIMENSION	SIMBOLO - SYMBOL	mm
PROFONDITA' - DEPTH	P	MIN: 1500
LARGHEZZA - WIDTH	M	MIN: 600 MAX: 900
ALTEZZA - HEIGHT	T	MIN: 800 MAX: 960
ALTEZZA PIANO - TOP HEIGHT	H	MIN: 55
SPESSORI PIANO - TOP THICKNESS	S	MIN: 18
LUNGHEZZA PIANO - TOP LENGTH	L	1500
LARGHEZZA PIANO - TOP WIDTH	Z	600/700/800/900
APERTURA PIANO 1 - TOP OPENING 1	E1	900
APERTURA PIANO 2 - TOP OPENING 2	E2	300

POSIZIONE FORI FISSAGGIO
MECCANISMO
HOLES FOR MECHANISM POSITION

DIMENSIONI PIANO
TOP DIMENSIONS

B. Bussola M6 - M6 bush (x 19)

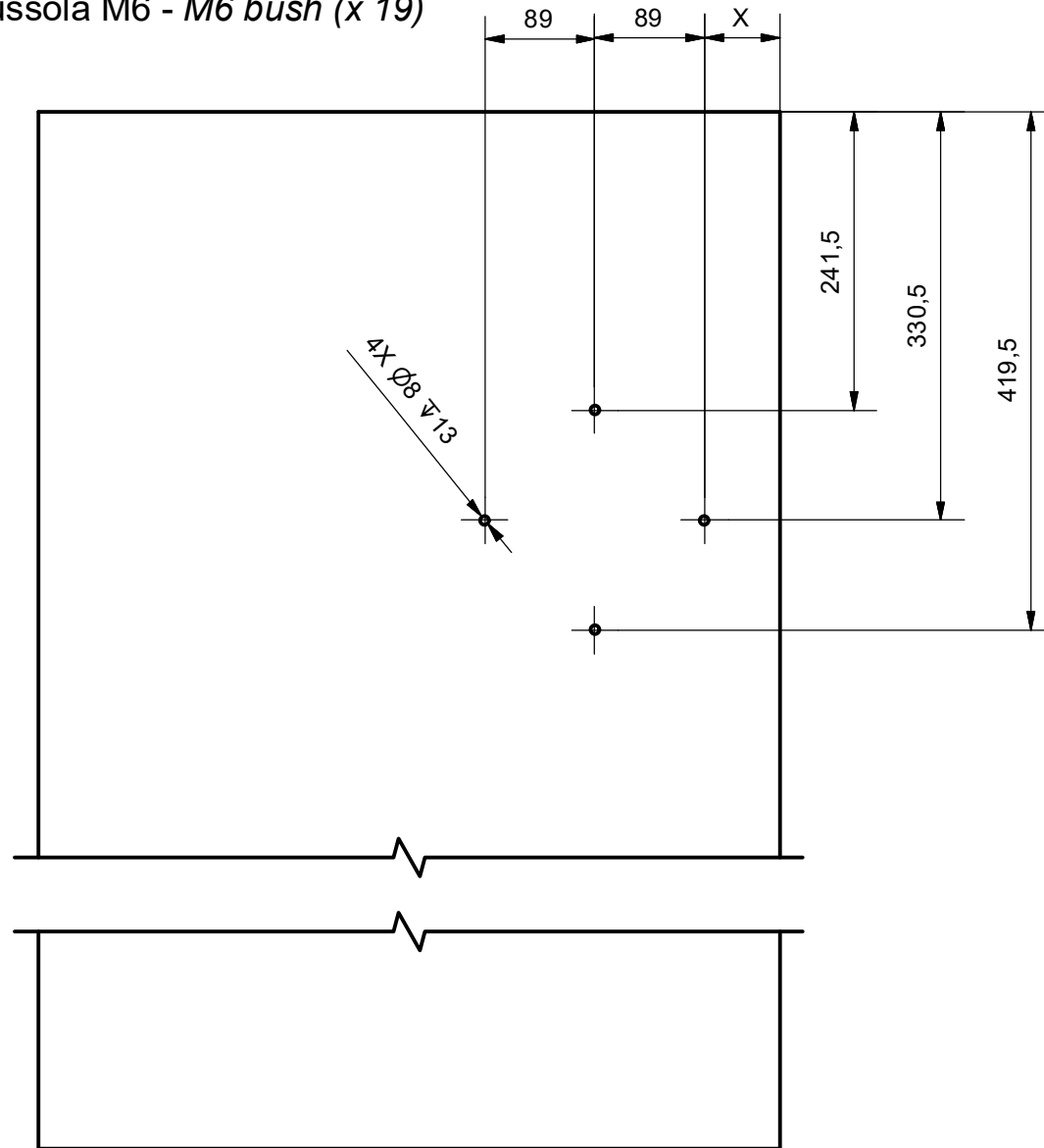

DIMENSIONE - DIMENSION	X (mm)
411/78.1290.22	59
411/78.1291.22	109
411/78.1292.22	159
411/78.1293.22	209

FRONTE - FRONT

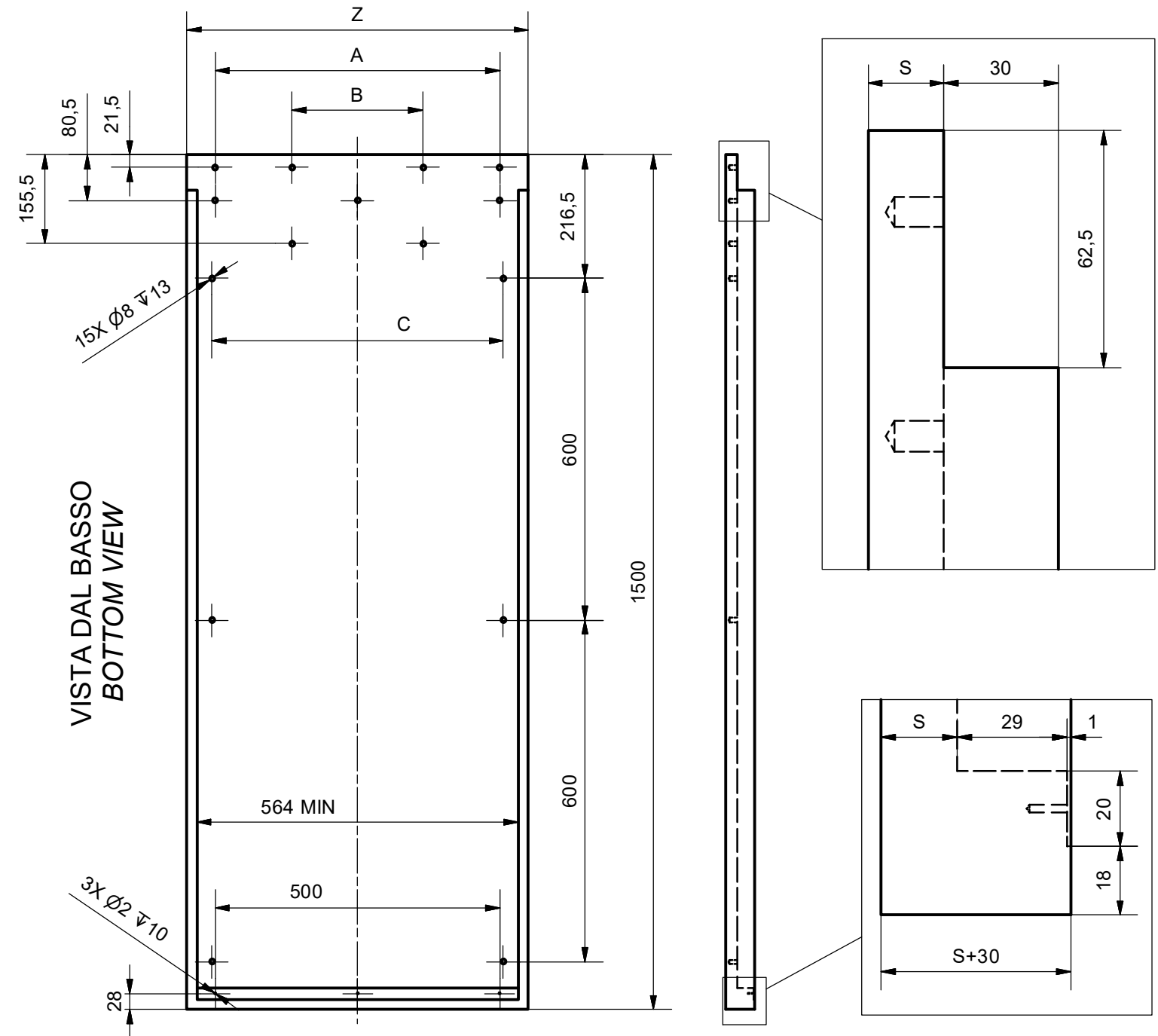

DIMENSIONE - DIMENSION	Z (mm)	A (mm)	B (mm)	C (mm)
411/78.1290.22	600	500	230	512
411/78.1291.22	700	600	330	512
411/78.1292.22	800	700	430	512
411/78.1293.22	900	800	530	512

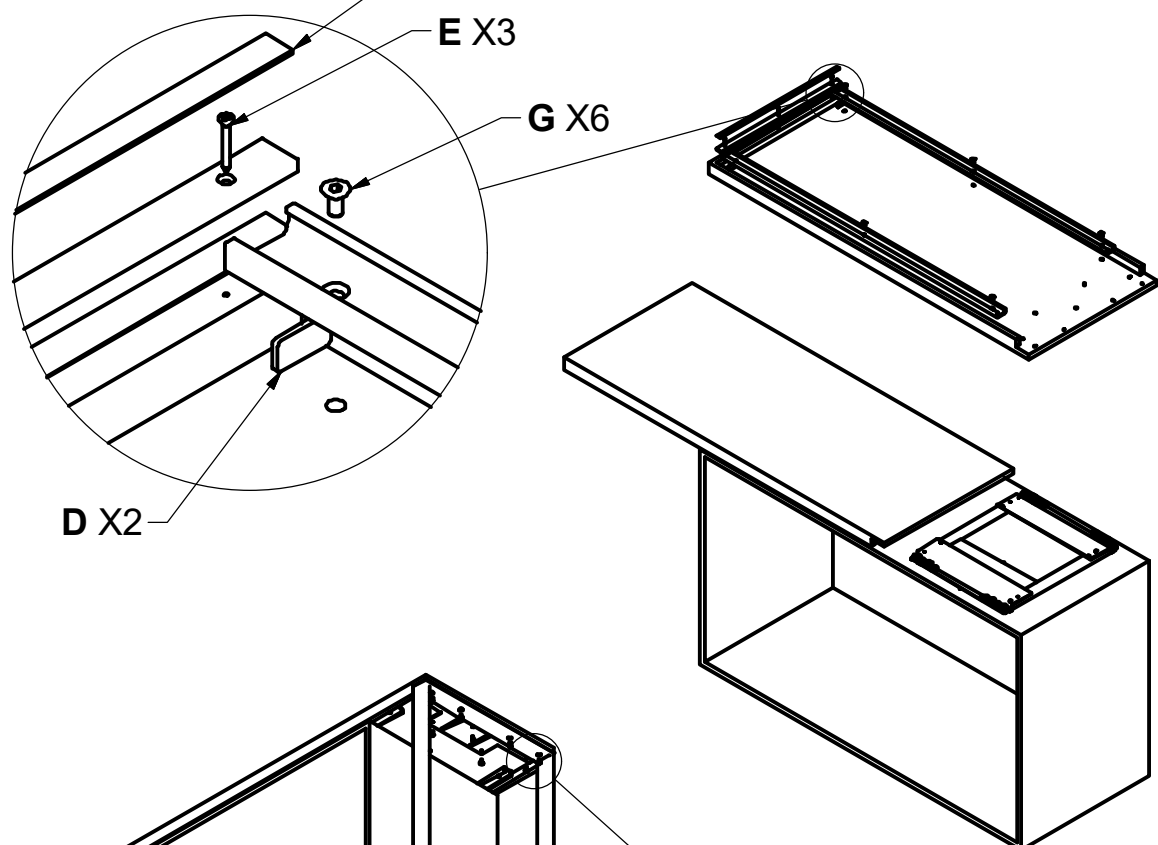
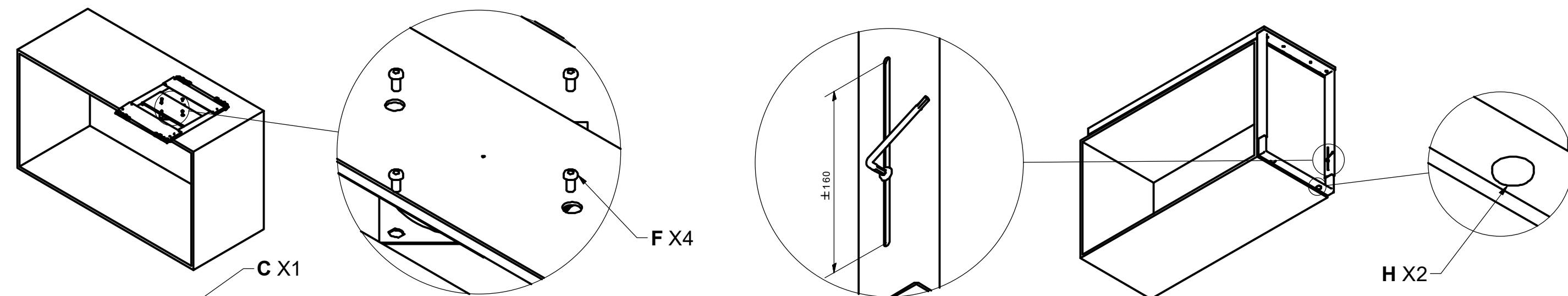

SEQUENZA DI FUNZIONAMENTO - FUNCTIONING STEPS

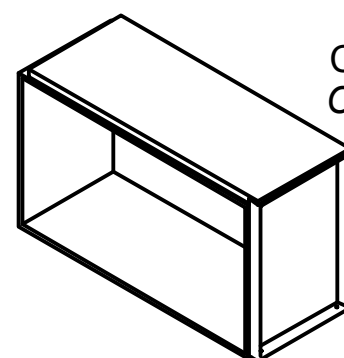

CHIUSO
CLOSED

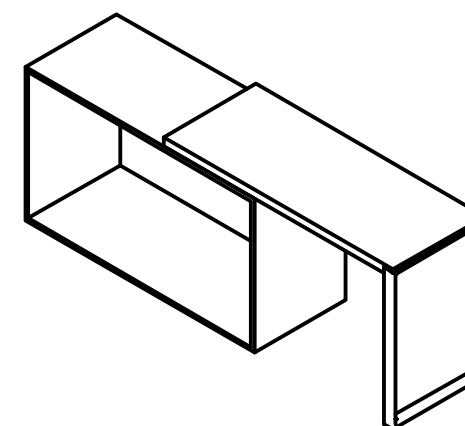

APERTO
OPENED

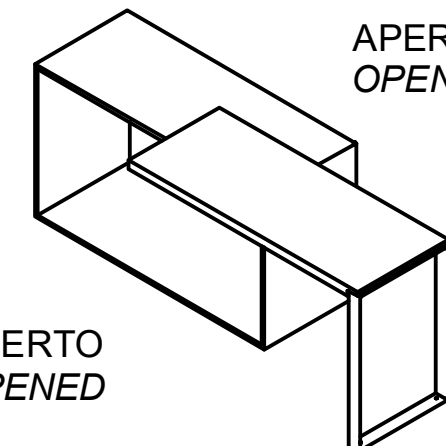

APERTO
OPENED

SACCHETTO ACCESSORI 1 - ACCESSORIES 1 (Per tutti i modelli - For all models)

- A. Chiave esa. n.4 - n.4 Allen key
- B. Bussola M6 - M6 bush (x 19)
- C. Feltro 560 mm - Felt 560 mm (x 1)
- D. Feltro 30 mm - Felt 30 mm (x 2)
- E. Vite truciolare 3.5x24 - 3.5x24 FHP screw (x 3)
- F. Vite TCB M6x12 - M6x12 BHCS screw (x 13)
- G. Vite TPS M6x12 - M6x12 FHCS screw (x 6)
- H. Pattino - Runner (x 2)

