

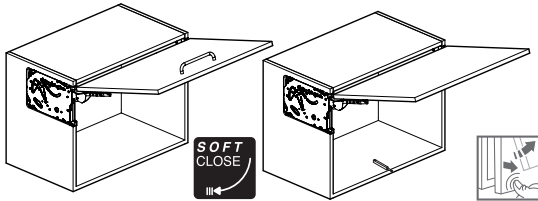

FREEslim flap FREEslim flap pto

116532



4069670000

P2 (EN 312)	
15-19 mm	660 kg/m ³
>19 mm	620 kg/m ³

en: The furniture manufacturer is responsible for the stability of the furniture construction.

fr: Le fabricant de meubles est responsable de la stabilité de la construction du meuble.

de: Für die Stabilität der Möbelkonstruktion ist der Möbelhersteller verantwortlich.

it: Il produttore di mobili è responsabile per la stabilità della costruzione del mobile.

es: El fabricante de muebles es responsable para la estabilidad de la construcción del mueble.

A 2x

E 2x

F 2x

M 8x
ø 4 x 15

C 2x

D 2x

L 2x

N

G 2x

B 4x

O 8x
ø 3,5 x 9,5

push

I

J

K

272449XXXX

272450XXXX

≥19

[WS242]

10.10.2025

i

„mm“

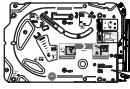

Article No: 2724390006
 Check Date: 02/09/25
 Model: soft close
 Spring: 2x3 mm

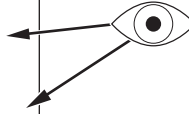

PF* = KH x kg * Power Factor	FREEslim flap soft close	FREEslim flap pto	pto-Stößel
	2724390006	2724420006	2724490006
	PF 480 - 4800	PF 480 - 4080	
KH	kg	kg	
225	2.1 - 21.3	2.1 - 18.1	Type 3 - strong (17.5 - 36.8 N)
250	1.9 - 19.2	1.9 - 16.3	
275	1.7 - 17.5	1.7 - 14.8	
300	1.6 - 16.0	1.6 - 13.6	
325	1.5 - 14.8	1.5 - 12.6	
350	1.4 - 13.7	1.4 - 11.7	
375	1.3 - 12.8	1.3 - 10.9	
400	1.2 - 12.0	1.2 - 10.2	
425	1.1 - 11.3	1.1 - 9.6	
450	1.1 - 10.7	1.1 - 9.1	
475	1.0 - 10.1	1.0 - 8.6	
500	1.0 - 9.6	1.0 - 8.2	
525	0.9 - 9.1	0.9 - 7.8	
550	0.9 - 8.7	0.9 - 7.4	
575	0.8 - 8.3	0.8 - 7.1	
600	0.8 - 8.0	0.8 - 6.8	
625	0.8 - 7.7	0.8 - 6.5	
650	0.7 - 7.4	0.7 - 6.3	

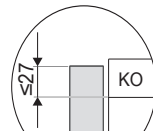
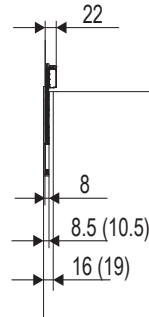
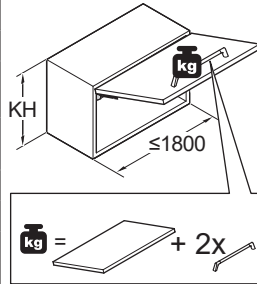

KO	Y	X
16 (19)	16	61 (71)
	18	54 (64)
	19	51 (61)
	22	41 (51)
	24	34 (44)
	26	27 (37)
	28	20 (30)

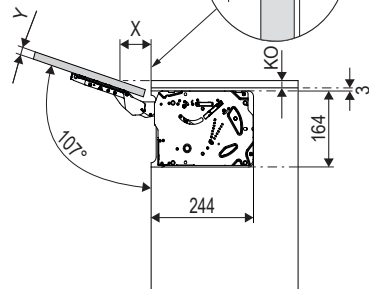

116532

4069670000

[WS242]

10.10.2025

1



ø 5 mm



ø 10 mm



„mm“

116532

4069670000

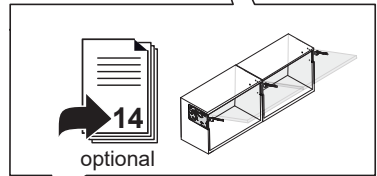
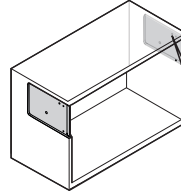
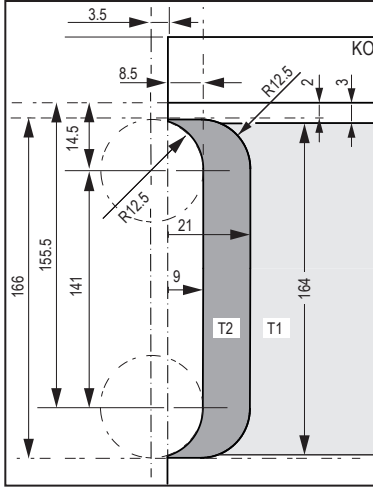

[WS242]

10.10.2025

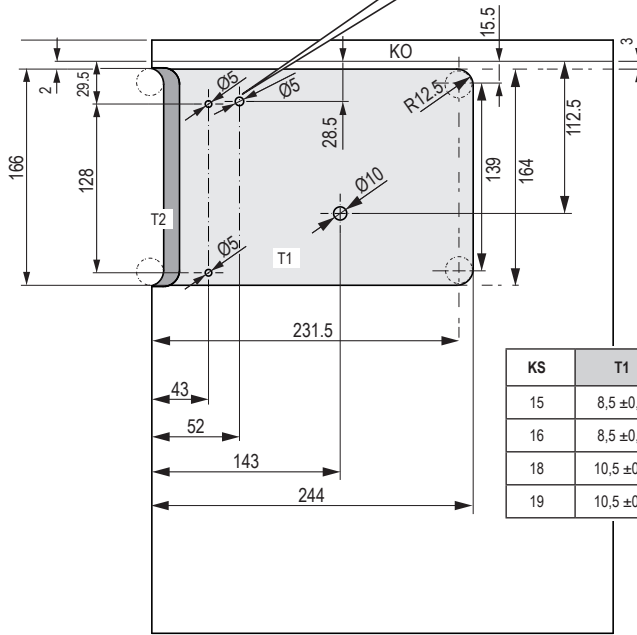

KS	T1	T2
15	8,5 ±0,5	11 ±0,5
16	8,5 ±0,5	11 ±0,5
18	10,5 ±0,5	13 ±0,5
19	10,5 ±0,5	13 ±0,5

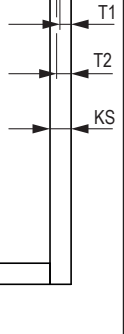

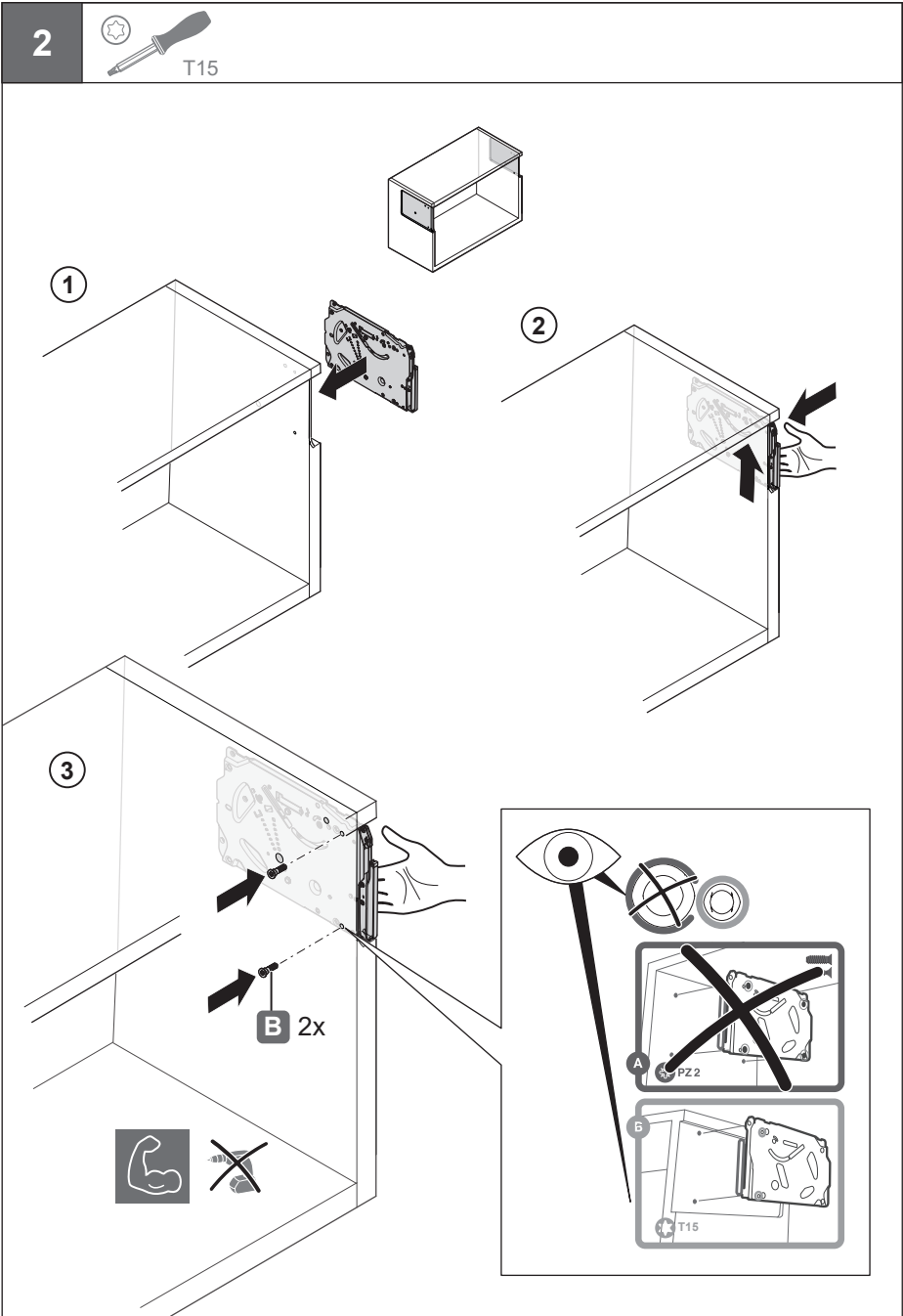

3

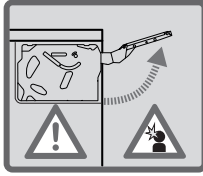

MIN. FORCE

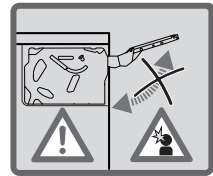
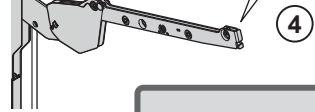
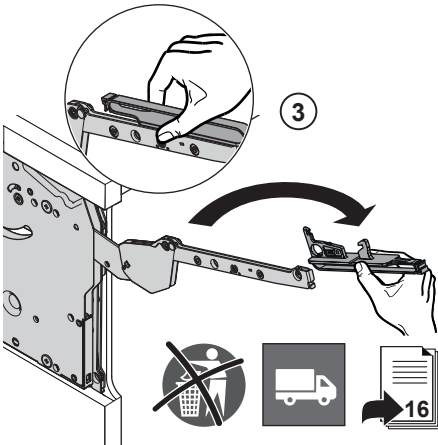
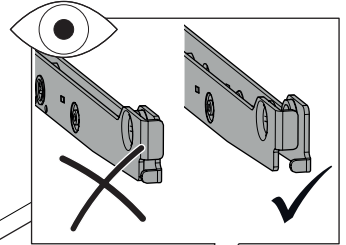
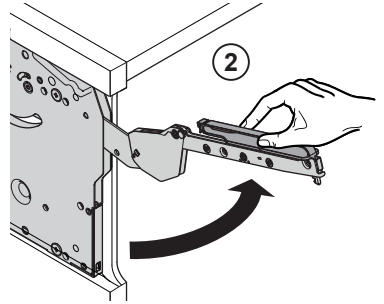
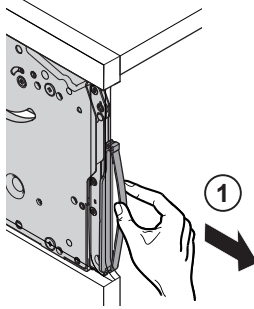

116532

4069670000

4a

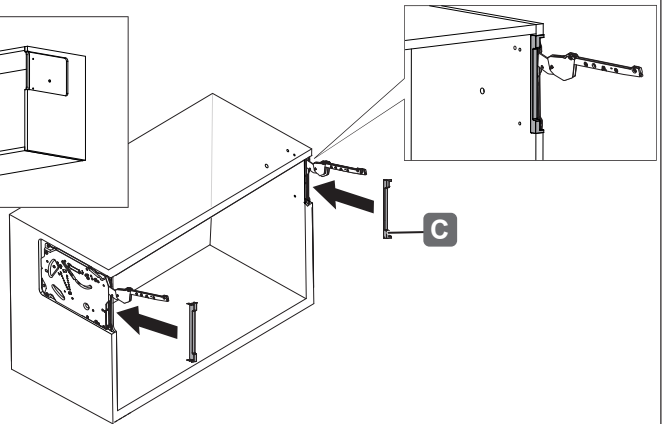
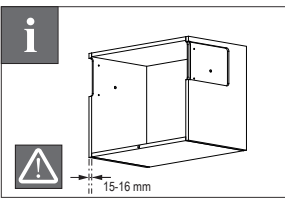

[WS242]

10.10.2025

4b

„mm“

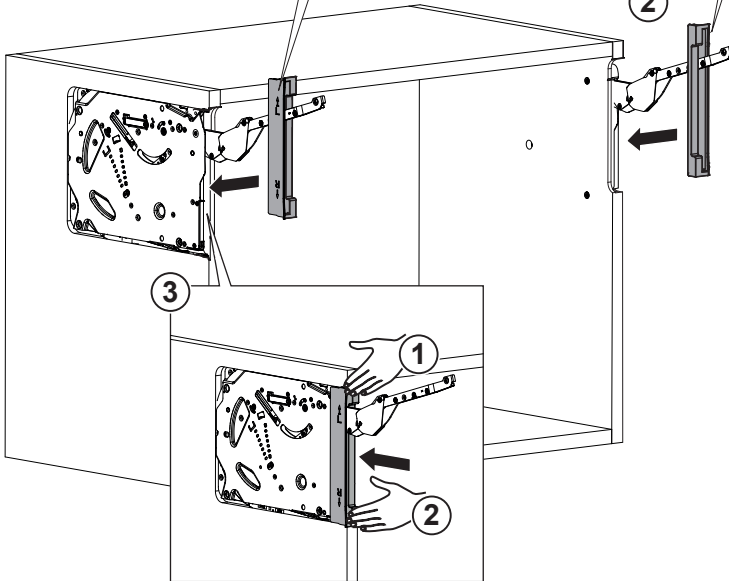
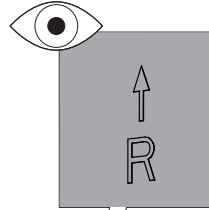
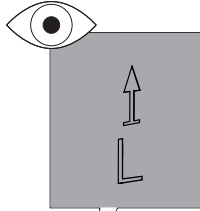
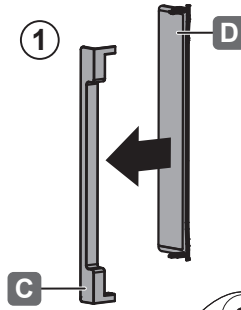
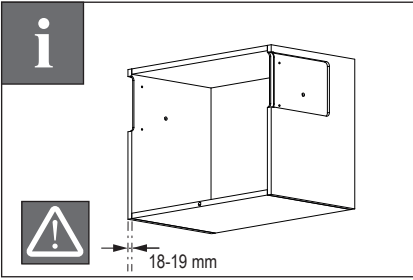

116532

4069670000

[WS242]

10.10.2025

5



Ø 10 mm



PZ 2



push

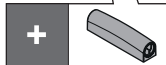
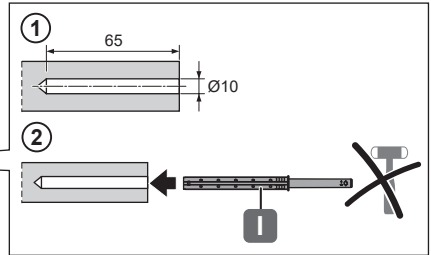
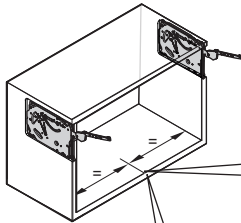

①

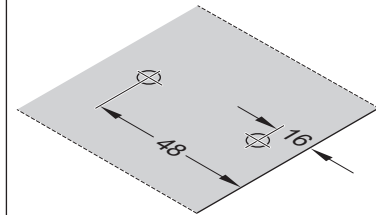

②

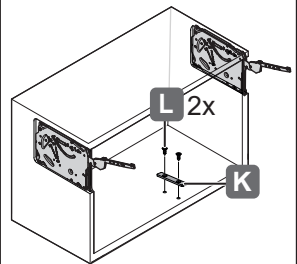

③

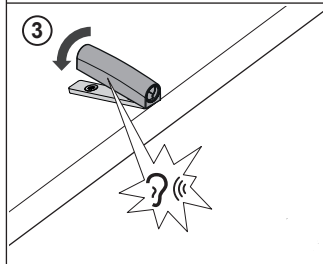

④

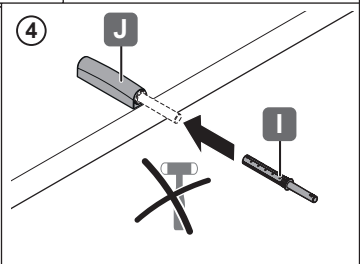

116532

4069670000

[WS242]

10.10.2025

6 „mm“

RB	KS	
	15-16 mm	18-19 mm
19 mm	Fmin = 2 mm	Fmin = 4 mm
20 mm	Fmin = 1 mm	Fmin = 3 mm
21 mm	Fmin = 0 mm	Fmin = 2 mm
22 mm	Fmin = 0 mm	Fmin = 1 mm
≥ 23 mm	Fmin = 0 mm	Fmin = 0 mm

KS	X
15-16 mm	12.5-F
18-19 mm	14.5-F

116532

4069670000

7 „mm“

[WS242]

10.10.2025

8

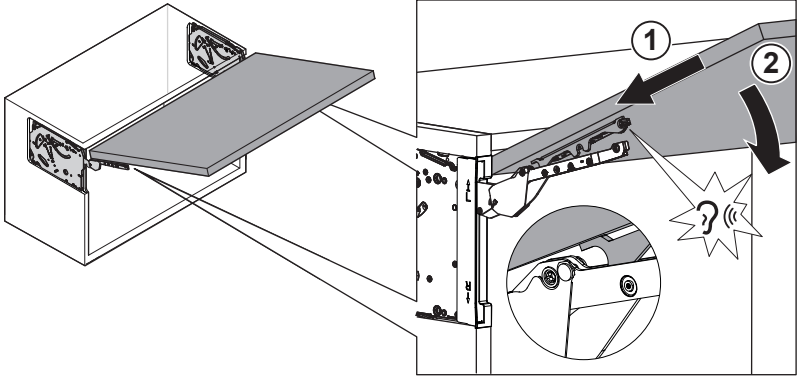

116532

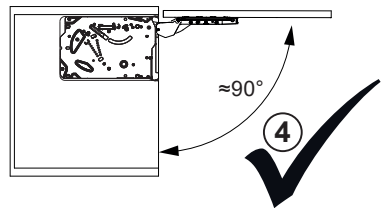
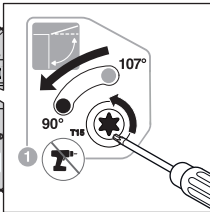
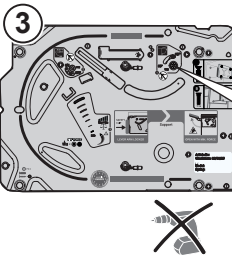
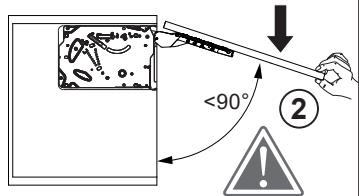
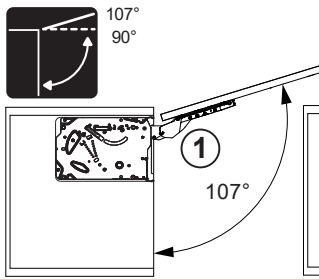
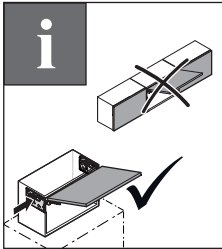

4069670000

9





[WS242]

10.10.2025

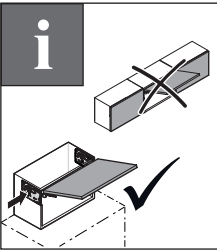
10  T15 

i 

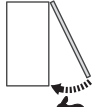
SOFT CLOSE

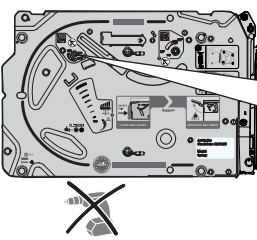
 $PF \geq 2.500$ ON + ON
 $PF < 2.500$ ON + OFF

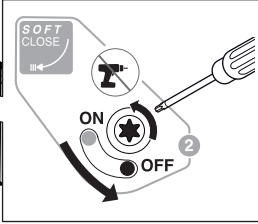



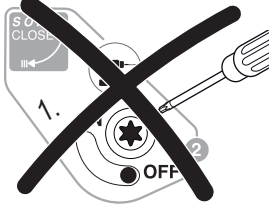

i  **push**



116532

4069670000

11  PZ2 

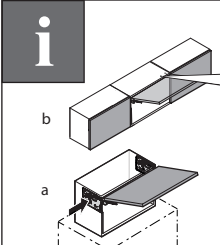
i 

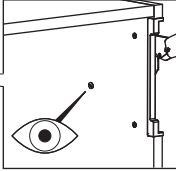

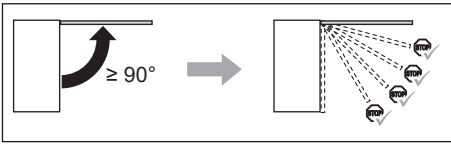

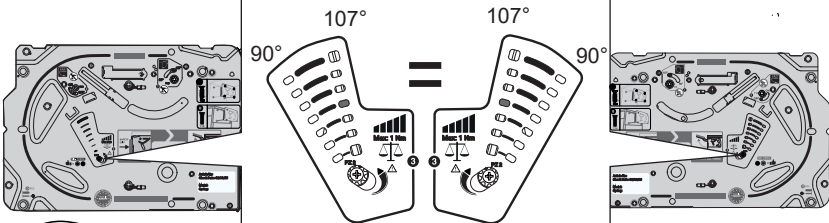











[WS242]

10.10.2025

12



push

116532

4069670000

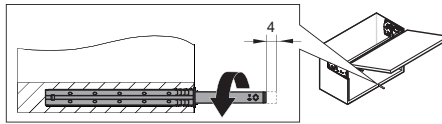
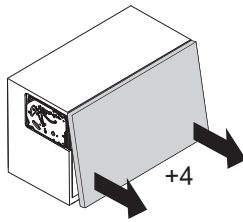

[WS242]

10.10.2025

13

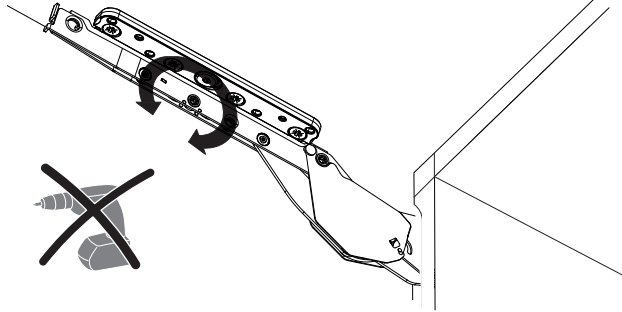
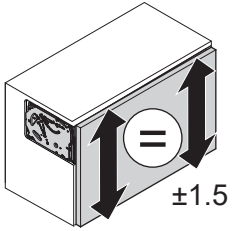

116532

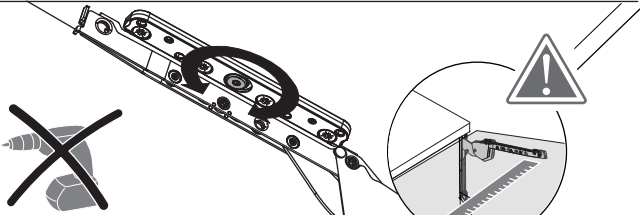
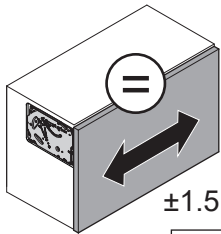

4069670000

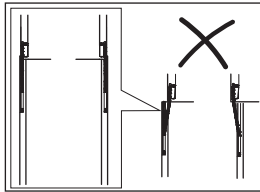

KS	Z
15-16	KB - 13.5
18-19	KB - 17.5

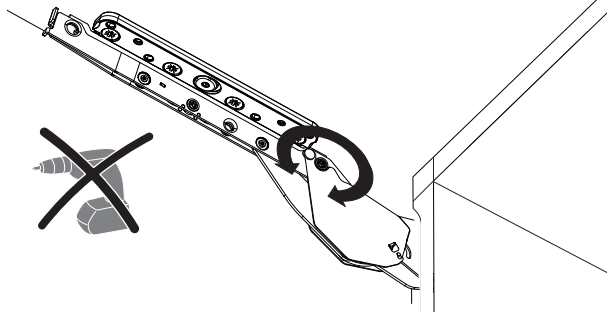
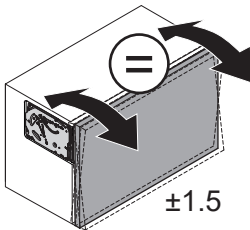
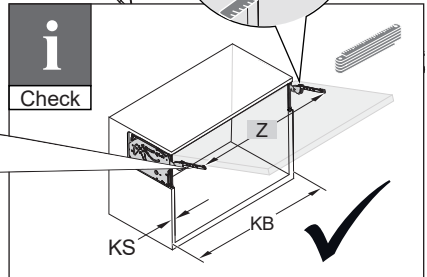

[WS242]

10.10.2025

14

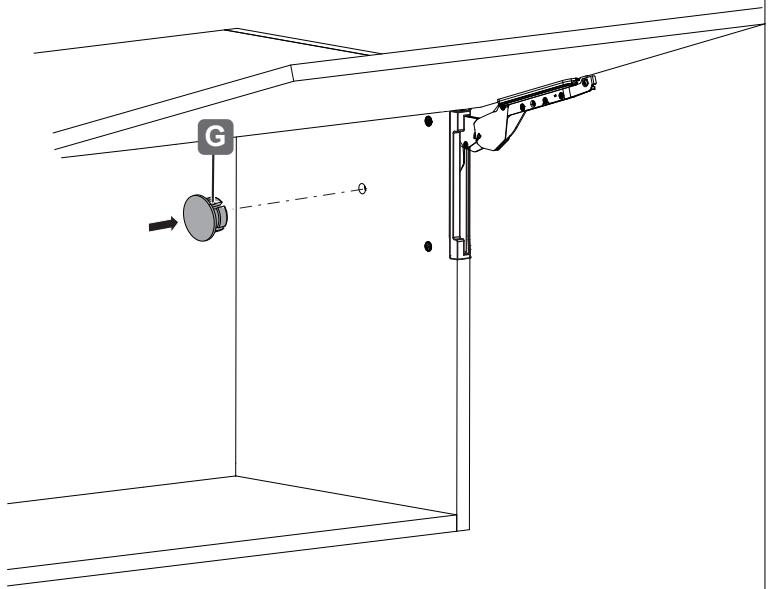
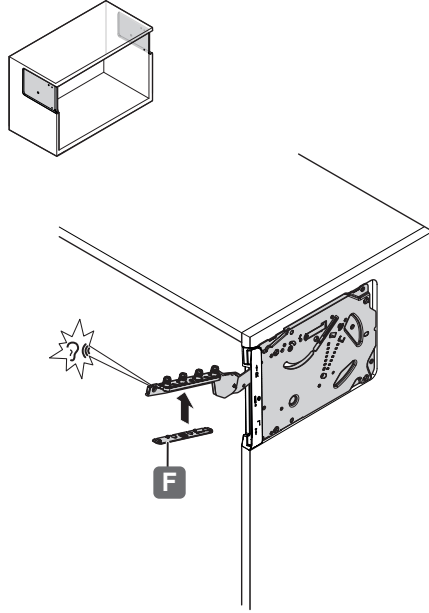

116532

4069670000

[WS242]

10.10.2025

15

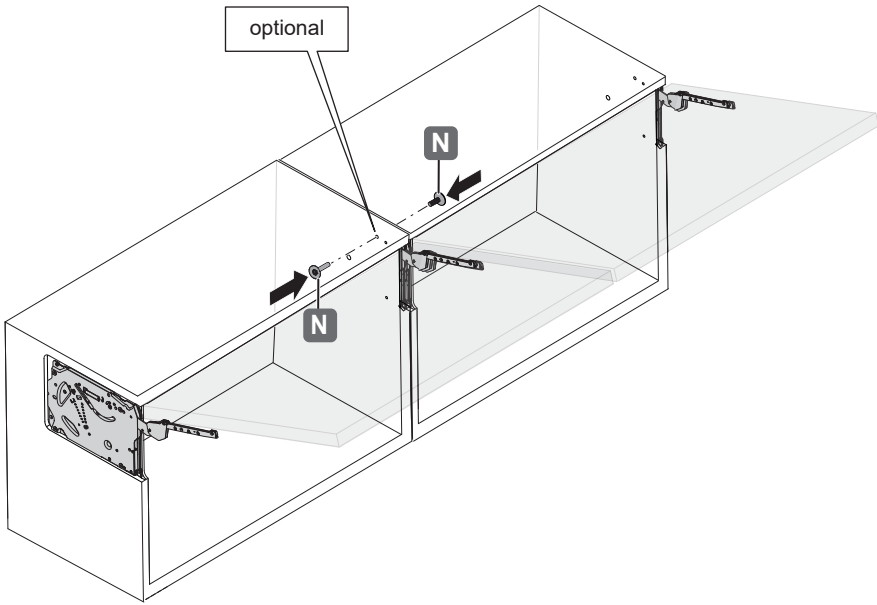

116532

4069670000

[WS242]

10.10.2025



PZ 2

116532

4069670000

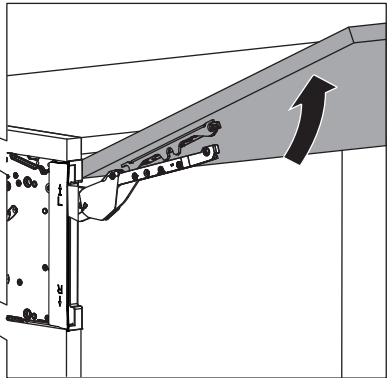
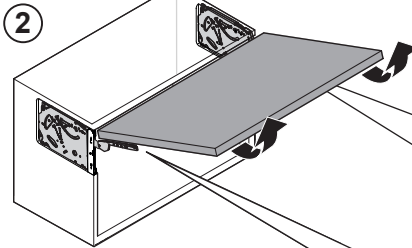
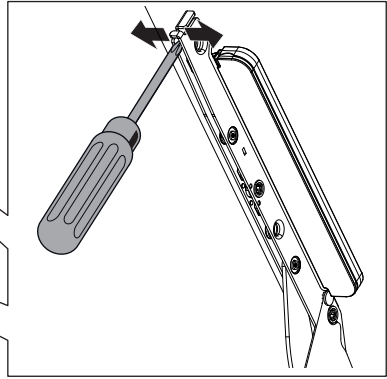
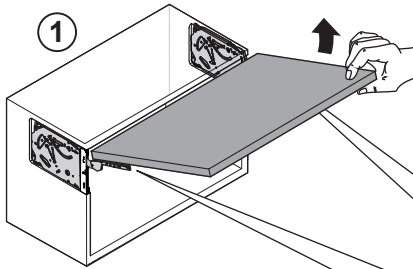

[WS242]

10.10.2025

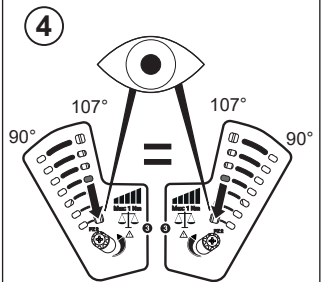
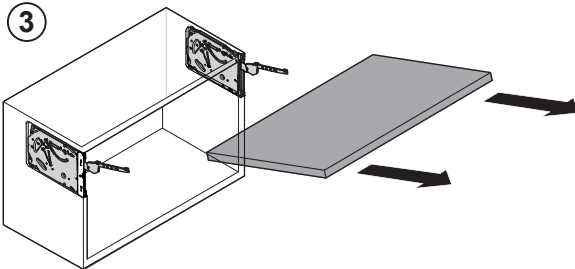

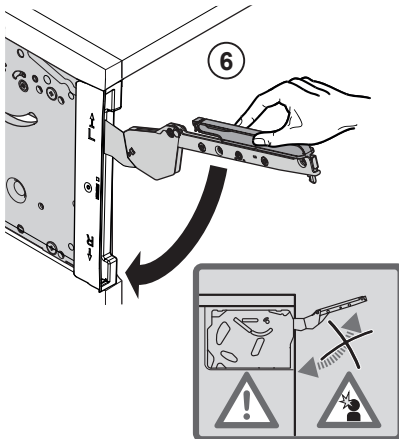
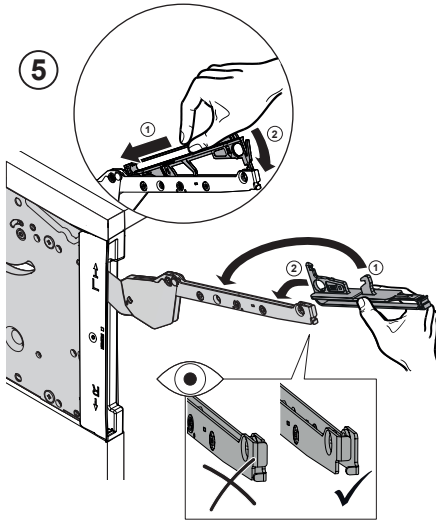

116532

4069670000

[WS242]

10.10.2025